

## Display Pac-PPC

12.1"/15.0" TFT

Intel® Celeron/Pentium® III

Plastic-housing Panel PC with

*Versatile* Stand design

User's Manual (Version 3.1)



## **Copyright Notice**

This document is copyrighted, 2002 by manufacturer. The information provided in this document has been carefully checked and is accurate at the time of publication. However, Computer Dynamics assumes no responsibility for any infringements of patents or other rights of third parties that may result from its use.

No part of this publication may be reproduced, stored in a retrieval system, or transmitted in any form of or via any means without the prior written permission of the manufacturer. Further, this publication and features described herein are subject to change without notice.

## **Trademarks**

All brand and product names used for identification in this document are trademarks or registered trademarks of their respective companies.

© Copyright 2002, Version 3.1

All rights reserved.

## Unpacking

After unpacking the **DISPLAY PAC-PPC** carton, check and see if the following items are included and in good condition.

- ◆ **DISPLAY PAC-PPC main system**  
x 1
- ◆ Accessories
  - Power cord x 1
  - D-Sub 15 pin external FDD cable x 1
  - Mini DIN 8 pin external FDD power cable x 1
  - User manual diskette in .pdf format x 1
  - Utilities, drivers & user manual CD diskette x 1
  - Mounting kit (optional) x 1 set
  - Stand kit x 1 set
  - Screw packet
- ◆ Warranty card

Make sure that all of the items listed above are present. If any of the above items is missing, contact your dealer immediately.

## Warranty

All products manufactured by the manufacturer are warranted against defective materials for one year starting from the date of delivery to the original purchaser.

## **Important Safety Precautions**

Before getting started, read these instructions and save them for later reference.

1. Turn off the computer before cleaning. Clean with a damp or dry cloth only. Do not spray any liquid cleaner on screen directly.
2. The power outlet socket used to plug in the computer power cord must be located near the system and easily accessible. Do not use outlets on the same circuit of the systems that regularly switched on and off.
3. Make sure the voltage of the power source is correct before connecting the computer to the power outlet.
4. If the computer is sharing an extension cord with other devices, make sure the total ampere rating of the devices plugged into the extension cord does not exceed the cord's ampere rating.
5. Do not expose the power cord, extension cord and power outlet to moisture.
6. Install the computer on a reliable surface to prevent damage caused by dropping.
7. This computer is not equipped with an operating system. An operating system must be loaded first before installing any software into the computer.
8. Disconnect the power cord from the computer before any installation. Make sure both the computer and the external devices are turned off. The sudden surge of power may ruin any sensitive components. Also make sure the computer is properly grounded.
9. During installation of any internal components, be sure to ground yourself to keep from any static charge. Most electronic components are sensitive to the static electric charge. Use a grounding wrist strap and place all electronic components in any static-shielded devices.

10. The openings on the computer enclosure are for the cabin ventilation to prevent the computer from overheating. DO NOT COVER THE OPENINGS.
11. The brightness of the flat panel display will decrease with use. However, hours of use will vary depending on the application environment.
12. If the computer is equipped with a touch panel, avoid using sharp objects to operate the touch panel. Scratches on the touch panel may cause mal-calibration or non-function to the panel.
13. The LCD panel display is not subject to shock or vibration. When assembling the computer, make sure it is securely installed.

# Table of Contents

<b>1. INTRODUCTION .....</b>	<b>1-1</b>
1.1. GENERAL INFORMATION .....	1-2
1.2. WHAT COVERS IN THIS MANUAL .....	1-3
1.3. SPECIFICATIONS .....	1-5
1.4. DIMENSIONS .....	1-9
1.4.1. DISPLAY PAC-PPC 12.1" <i>Error! Bookmark not defined.</i>	
1.4.2. DISPLAY PAC-PPC 15.1" <i>Error! Bookmark not defined.</i>	
<b>2. USING THE SYSTEM .....</b>	<b>2-11</b>
2.1. IDENTIFYING THE SYSTEM .....	2-12
2.1.1. Front View .....	2-12
2.1.2. Side Views .....	2-13
2.1.3. I/O Outlets .....	2-14
2.2. SYSTEM SETUP FOR THE FIRST-TIME USE .....	2-15
2.2.1. Installation Procedures .....	2-15
2.2.2. Running the BIOS Setup .....	2-16
2.2.3. Operating System and Driver Installation .....	2-17
<b>3. VERSATILE STANDING &amp; MOUNTING OPTIONS .....</b>	<b>3-19</b>
3.1. UPRIGHT DESKTOP STANDING .....	3-23
3.2. 30 TO 47° DESKTOP STANDING .....	3-24
3.3. OTHER STAND OPTIONS .....	3-25
3.3.1. 60 to 90° Desktop Standing .....	3-25
3.3.2. 80° Desktop Fixed Standing .....	3-26
3.4. WALL MOUNTING AND MOBILE APPLICATIONS .....	3-27
3.5. PANEL MOUNTING .....	3-28
<b>4. I/O CONNECTION .....</b>	<b>4-29</b>
4.1. PARALLEL PORT .....	4-30
4.2. COM PORTS x 4 .....	4-31
4.3. 100/10 BASE-T ETHERNET (RJ-45) .....	4-33
4.4. VGA INTERFACE .....	4-34
4.5. PS/2 KEYBOARD INTERFACE .....	4-34
4.6. PS/2 MOUSE INTERFACE .....	4-34
4.7. EXTERNAL FDD (DB-15) .....	4-35
4.8. +5V/12V DC-OUT .....	4-36

4.9.	VR BRIGHTNESS CONTROL .....	4-36
4.10.	DIO (DIGITAL INPUT & OUTPUT) .....	4-37
4.11.	TV-OUT INTERFACE (OPTIONAL) .....	4-39
4.12.	AUDIO INTERFACE (LINE-IN, MIC-IN, SPK-OUT) .....	4-40
4.13.	USB PORTS .....	4-40
4.14.	AC/DC INLET/POWER SWITCH.....	4-40
<b>5.</b>	<b>HARDWARE INSTALLATION AND UPGRADE.....</b>	<b>5-41</b>
5.1.	RECOGNIZING THE SYSTEM MAJOR PARTS.....	5-43
5.2.	TOUCH SCREEN MODULE ASSEMBLY .....	5-44
5.3.	LCD MODULE ASSEMBLY .....	5-45
5.4.	POWER MODULE ASSEMBLY .....	5-47
5.5.	INSTALLING THE CPU .....	5-48
5.6.	INSTALLING THE SDRAM MEMORY MODULE.....	5-49
5.7.	INSTALLING THE HDD .....	5-50
5.8.	INSTALLING THE FDD.....	5-52
5.8.1.	External FDD connection.....	5-52
5.8.2.	Internal FDD installation .....	5-53
5.9.	INSTALLING THE CD-ROM OR DVD-ROM.....	5-55
5.10.	EXPANSION SLOTS .....	5-56
5.10.	EXPANSION SLOTS .....	5-57
<b>6.</b>	<b>SYSTEM CONTROL BOARD.....</b>	<b>6-59</b>
6.1.	INTRODUCTION .....	6-60
6.1.1.	General Information .....	6-60
6.1.2.	Features .....	6-61
6.1.3.	Specifications.....	6-62
6.1.4.	Board Placement & Dimension .....	6-64
6.1.5.	Jumpers & Jumper Setting.....	6-65
6.1.5.1.	J1: CD Audio Input Connector.....	6-66
6.1.5.2.	J2: VGA Interface Connector for A/D Board.....	6-66
6.1.5.3.	CMOS Clear Setting (JP2).....	6-66
6.1.5.4.	DOC 2000 Address Setting (JP5).....	6-67
6.1.5.5.	COM 2 RS-232/485 Setting (JP6, 7, 8).....	6-67
6.1.6.	Connectors & Pin Assignment .....	6-68
6.1.6.1.	CN1: FDD Connector .....	6-69
6.1.6.2.	FAN1: FAN Connector .....	6-69
6.1.6.3.	CN2: Main Power Connector.....	6-70
6.1.6.4.	CN3: KB, MS, USB & LPT Connector .....	6-71

6.1.6.5.	CN4: Audio, Ethernet VGA CRT & LED Connector	6-72
6.1.6.6.	CN5: Digital I/O Connector .....	6-73
6.1.6.7.	CN6: IR and Serial Ports Connector .....	6-74
6.1.6.8.	CN7: PCI/ISA Expansion Slot .....	6-75
6.1.6.9.	CN8/CN9: Flat Panel Connector.....	6-78
6.1.6.10.	CN9: LCD Backlight Connector.....	6-79
6.1.6.11.	IDE1/IDE2: IDE Connector.....	6-80
<b>7.</b>	<b>AWARD BIOS SETUP .....</b>	<b>7-83</b>
7.1.1.	<i>Main Menu.....</i>	7-84
7.2.	AWARD BIOS SETUP .....	7-84
7.2.1.	<i>AWARD BIOS Setup Main Menu .....</i>	7-84
7.2.2.	<i>Standard CMOS Features .....</i>	7-86
7.2.3.	<i>Advanced BIOS Features .....</i>	7-90
7.2.4.	<i>Advanced Chipset Features.....</i>	7-91
7.2.5.	<i>Integrated Peripherals .....</i>	7-92
7.2.6.	<i>Power Management Setup .....</i>	7-93
7.2.7.	<i>PnP/PCI Configuration .....</i>	7-94
7.2.8.	<i>Frequency Voltage Control .....</i>	7-95
7.2.9.	<i>Load Fail-Safe Defaults.....</i>	7-96
7.2.10.	<i>Load Optimized Defaults .....</i>	7-97
7.2.11.	<i>User Password.....</i>	7-98
7.2.12.	<i>Save and Exit Setup.....</i>	7-99
7.2.13.	<i>Exit Without Saving.....</i>	7-100
<b>8.</b>	<b>TOUCH SCREEN.....</b>	<b>8-101</b>
8.1.	ELO TOUCH SCREEN DRIVER INSTALLATION .....	8-102
8.1.1.	<i>System Requirements.....</i>	8-102
8.1.2.	<i>About Elo Software .....</i>	8-103
8.1.3.	<i>Installation.....</i>	8-104
8.1.4.	<i>Installing MonitorMouse for Windows system .....</i>	8-106
8.1.5.	<i>Getting More Information.....</i>	8-110
	APPENDIX.....	8-111
	A: PROGRAMMING THE WATCHDOG TIMER .....	8-111
	B: DISKONCHIP® INSTALLATION .....	8-113
	C: RS-485 PROGRAMMING.....	8-114
	D: SYSTEM I/O PORTS .....	8-115
	E: FIRST MB MEMORY MAP.....	8-116

F:TV-OUT INTERFACE (OPTIONAL SiS301 BOARD).....	8-117
G: POWER SUPPLY .....	8-120



## **1. INTRODUCTION**

This chapter provides background information and detail specification on the DISPLAY PAC-PPC. Sections in this chapter include:

- ◆ General Information
- ◆ What covers in this Manual
- ◆ Specification
- ◆ Dimension

## **1.1. General Information**

The information revolution which started from the mid '90 inaugurated a new competitive era where consumer-computing technology was exploited to business operation quicker than ever before. Many enterprises from our life related industries such as **POS, POI, KIOSK, Banking, Medical** to the high-tech **Telecom, Aerospace, Semiconductor** ... etc. all are eager or forced to automate their industries with PCs in order to thrive in this new age. For their industrial automation, there is one thing in common, i.e. space is always a premium and system stability is always a must in their environmental applications.

The **DISPLAY PAC-PPC** is a series of 12.1"/15" multimedia Intel Celeron or Pentium® III panel PCs designed to serve as a friendly human-machine-interface for easy integration into any space-constricted embedded applications.

In terms of panel size, the DISPLAY PAC-PPC has 12.1" and 15" systems.

Onboard features include super I/Os, XGA, 12.1"/15" TFT flat panel, touch screen, Ethernet and multimedia functions. The full PC functionality coupled with its multi-I/Os stand ready to accommodate a wide range of PC peripherals. Special industrial features not commonly seen in commercial systems such as watchdog timer and water/dust proof front panel make it a best choice for the operation in any hostile environments.

Fully configurable and with its sleek outlook, the **DISPLAY PAC-PPC(661)** is an ideal platform for any space-constricted application.

## **1.2. What Covers in this Manual**

This handbook contains most information you need to set up and use the DISPLAY PAC-PPCsystem. You do not need to read everything in this handbook to use the system.

For a quick start, see the following chapter summaries;

**Chapter 1** (the current chapter) provides background information and detail specification on the DISPLAY PAC-PPC.

**Chapter 2** identifies the DISPLAY PAC-PPCsystem exterior components and provides instructions to help you to use the system as soon as possible.

**Chapter 3** details the panel PC's various standing and mounting options by graphical illustrations.

**Chapter 4** provides the procedures to connect external devices to the I/O interface

**Chapter 5** helps you to recognize the DISPLAY PAC-PPCsystem internal components. It also provides the installation procedures including LCD, touch screen, power supply module, CPU, system memory, FDD, HDD and CD-ROM drive.

**Chapter 6** provides detail information of the jumper settings and connector signals of the system control board.

**Chapter 7** explains the AWARD BIOS setup.

**Chapter 8** details the procedures to install the touch screen software drivers under DOS and Windows operation

**Appendix A** explains how to program the watchdog timer.

**Appendix B** introduces the DiskOnChip® installation.

**Appendix C** introduces the system I/O ports.

**Appendix D** explains the RS-485 programming.

**Appendix E** explains the first MB memory map.

**Appendix F** TV-out Interface (Optional SiS301 Board)

**Appendix G** provides the specifications for the built-in power supply.

## 1.3. Specifications

### SYSTEM

Flat Panel

- ◆ **DISPLAY PAC-PPC 12.1"** : 12.1" color TFT, 800\*600
  - Viewing angle 100
  - Luminance (cd/m<sup>2</sup>) 150 or above
  - Simultaneous mode yes
- ◆ **DISPLAY PAC-PPC 15.1"**: 15" color TFT, 1024\*768
  - Viewing angle 100
  - Luminance (cd/m<sup>2</sup>) 200 or above
  - Simultaneous mode yes

CPU (Socket 370)

- ◆ Intel Tualatin FCPGA2 up to 1.26GHz
- ◆ Intel Pentium III FCPGA 100/133 up to 1GHz
- ◆ Celeron FCPGA 66/100 up to 1.3GHz

System BIOS

- ◆ Award PnP Flash BIOS

System Memory

- ◆ 1\*168pin DIMM socket supporting SDRAM up to 512MB

L2 Cache

- ◆ CPU built-in

Standard I/O

- ◆ Serial Ports\*4 with +5V/12V power output on pin 9:  
3\*RS-232, 1\*RS-232/485 (COM2)
- ◆ Parallel Port\*1: supports SPP/EPP/ECP
- ◆ External FDD Interface\*1
- ◆ +5V/+12V DC-out\*1
- ◆ PS/2 Keyboard Interface\*1
- ◆ PS/2 Mouse Interface\*1
- ◆ DIO: Input\*2, output\*2 (RJ-12)
- ◆ USB Interface\*2
- ◆ VGA Interface\*1
- ◆ Brightness VR\*1
- ◆ Speaker-out, MIC-in, Line in
- ◆ TV out S-video/RCA (Optional)

Ethernet

100/10 Base-T Ethernet with RJ-45 phone jack

Watchdog Timer

- ◆ 64 level time intervals

Display

- ◆ Integrating VGA/LCD/Controller, advance hardware 2D/3D GUI engine
- ◆ Share System Memory Architecture which can flexibly utilize the frame buffer size up to 64MB

Expansion Slot

- ◆ PCI cards\*2 (L\*W) 290\*120 +160\*120 or
- ◆ PCI+ISA cards (L\*W) 290\*120 +160\*120

Front Bezel

- ◆ LED indicators for HDD, LAN, POWER
- ◆ Supports IrDA version 1.0 SIR protocol (Reserved)

## PERIPHERAL & STORAGE DEVICES

Touch screen (optional, sharing COM3)

- ◆ 12.1"/15" analog resistive type with RS-232 controller
- ◆ 12.1"/15" capacitive type with RS-232 controller
- ◆ 12.1"/15" surface acoustic wave type (SAW)

Power Supply

- ◆ AC 85W, input range: 85~264VAC @47~63Hz
- ◆ DC 90W, 9~132VDC (optional)

Speakers

- ◆ Speakers\*2

CD-ROM or DVD-ROM

- ◆ Slim type\*1 (optional)

Floppy Disk Drive

- ◆ Slim type\*1 (optional) or
- ◆ Via external FDD

Hard Disk Drive

- ◆ 3.5" HDD\*1 (optional)
- ◆ Space for 2.5" HDD\*2 (special design)

## **MECHANICAL & ENVIRONMENTAL**

### Construction

- ◆ Inside: heavy-duty steel
- ◆ Outside: fire-proof resilient plastic

### Color (standard)

- ◆ Beige: Pantone cool gray 3C
- ◆ Black: Pantone 3x2X

### Dimension (chassis only, unit: mm)

- ◆ DISPLAY PAC-PPC 12.1" : 368\*321.7\*107.5 (72)
- ◆ DISPLAY PAC-PPC 15.1": 412\*360\*120.7 (72.1)

### Mounting

- ◆ Panel mount with mounting kits
- ◆ Wall mount with swing arm: standard VESA mounting holes (100\*100 mm, 75\*75 mm)

### Versatile Stand

- ◆ STAND A: 30~47° (Pedestal + small base), standard
- ◆ STAND B: 60~90° (Pedestal + Prop), optional

- *Specifications are subject to change without notice.*

## 1.4. Dimensions

### 1.4.1. DISPLAY PAC-PPC 12.1"

The DISPLAY PAC-PPC 12.1" shares the same chassis but differ in the cut window size of the front bezel. Its chassis size is shown below. This does not include the dimension of the stand.

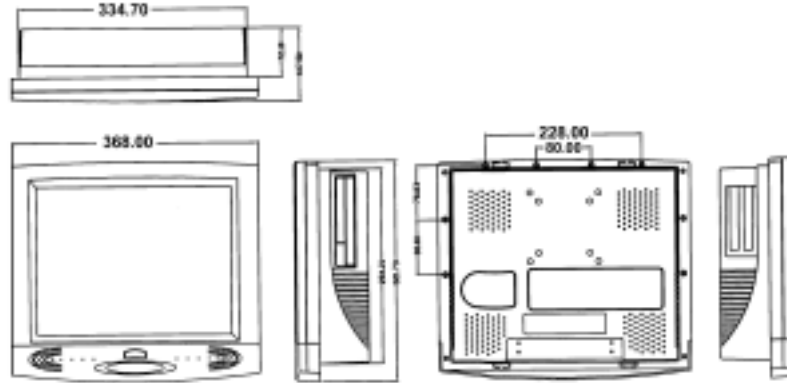

Dimension: unit (mm)

DISPLAY PAC-PPC 12.1" chassis size

### 1.4.2. DISPLAY PAC-PPC 15.1"

The DISPLAY PAC-PPC 15.1"'s chassis size is shown below.  
This does not include the dimension of the stand.

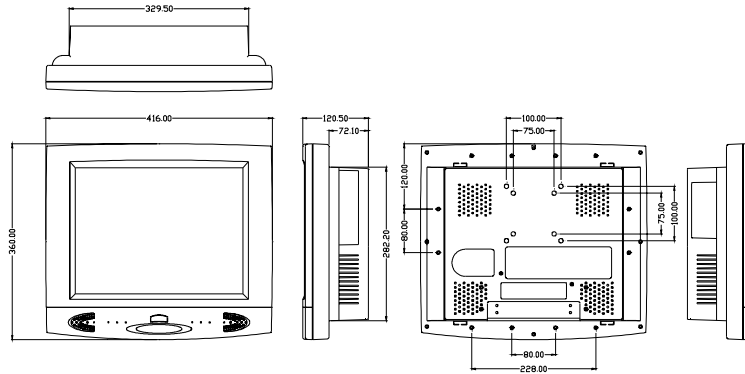

Dimension: unit (mm)

DISPLAY PAC-PPC 15.1" chassis

## **2. USING THE SYSTEM**

- ◆ Identifying the DISPLAY  
PAC-PPCsystem
- ◆ System setup for the first-time use

## 2.1. Identifying the System

Before getting started, take a moment to familiarize yourself with the system and the I/O arrangement of the DISPLAY PAC-PPC 120/150 .

### 2.1.1. Front View

When the DISPLAY PAC-PPC is put upright on the desktop with the provided pedestal, its front view appears as below.

The illustrations of the DISPLAY PAC-PPC may differ slightly because the DISPLAY PAC-PPC system series has three different LCD size: 12.1" & 15".

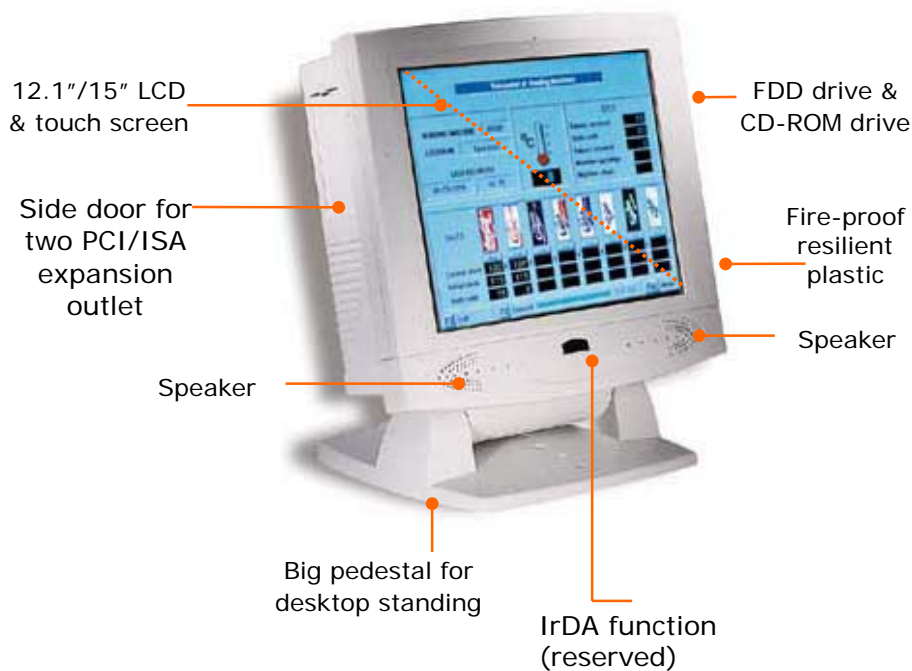

### 2.1.2. Side Views

The left side of the panel PC appears as below:



Versatile stand design for (30° to 47°) desktop standing

### 2.1.3. I/O Outlets

When you turn around the DISPLAY PAC-PPCsystem, you will find the power switch and all the I/O ports are located at the rear cover of the panel PC.

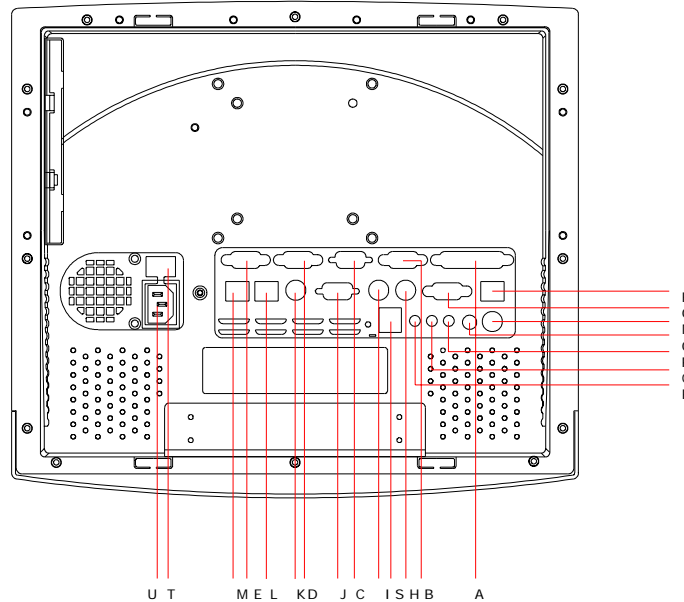

- |                  |   |   |
|------------------|---|---|
| A. Printer port  | B. COM4                                   | C. COM3                                 |
| D. COM2          | E. COM1                                   | F. Ethernet (RJ45)                      |
| G. VGA port      | H. PS/2 Keyboard                          | I. PS/2 Mouse                           |
| J. External FDD  | K. +5/12V DC-out                          | L. 2-channel DIO                        |
| M. VR brightness | N. TV-out S-terminal<br>(Optional SiS301) | O. TV-out RCA Jack<br>(Optional SiS301) |
| P. Line-in       | Q. Speaker out                            | R. MIC-in                               |
| S. USB ports     | T. Power switch                           | U. AC inlet                             |

## **2.2. System Setup for the First-time Use**

To set up the DISPLAY PAC-PPC for the first-time use, you should have the following items ready. The items are either in the accessory box or available in any computer stores.

- ◆ 110V or 220V power cord
- ◆ PS/2 or AT keyboard
- ◆ PS/2 or serial mouse

### **2.2.1. Installation Procedures**

The DISPLAY PAC-PPC system can be powered either by an AC electrical outlet (90 ~ 240V, 50 ~ 60Hz) or by DC power source (18 ~ 36 VDC). If the system is to be powered up by AC power, be sure to use the right power cord (110V or 220V) for connection.

1. Connect the female end of the power cord to the AC inlet located at the rear side of the panel PC.
2. Connect the 3-pin male end of the power cord to an electrical outlet.
3. Connect a PS/2 keyboard or an AT keyboard to keyboard port. If you are using an AT keyboard, you need an adapter (AT to PS/2 KB) for this connection.
4. Connect the PS/2 mouse to the PS/2 mouse port. If you are using a serial mouse, it can be connected to the COM port.
5. Power on the panel PC by switching the power switch located at the rear cover.

### **2.2.2. Running the BIOS Setup**

If you are a commercial user, the DISPLAY PAC-PPC should have been properly set up and configured by your dealer. You may still find it necessary to change the system configuration information. In this case, you need to run the system's BIOS setup program.

Under the following conditions, the CMOS settings are to be changed.

1. The system is starting for the first time.
2. The hardware devices attached to the DISPLAY PAC-PPC system have been changed.
3. The CMOS memory has lost power and the configuration information has been erased.

The BIOS setup program is stored in ROM, which can be accessed by pressing <DEL> key on the keyboard immediately when the system is powered on.

In order to retain the specified setup information when the system power is turned off, the system setup information is stored in a battery-backed CMOS RAM. The battery is to ensure the settings will not be erased when the computer is turned off or reset. When the computer is powered on again, the system will read the settings stored in the CMOS RAM and compare them to the equipment check conducted during the power on self-test (POST). If any error or mismatch occurs, an error message will be shown on the screen and the computer will be prompted to run the setup program.

To change the BIOS setup, please refer to Chapter 7 for more information.

### **2.2.3. Operating System and Driver Installation**

The DISPLAY PAC-PPCsystem is not equipped with an operating system when delivered from the original manufacturer. If you are a commercial user, the system is likely to have been pre-installed proper operating system and software drivers by your dealer or system integrator.

If the system is not pre-installed with any system OS and drivers or you intend to install your preferred ones, there are several ways to load OS and software into the system.

1. Via the external FDD or internal FDD
2. Via the CD-ROM
3. Via Ethernet: You can boot up the system via Ethernet boot Rom and download system OS or software from the network.

Recent releases of operating systems always include setup programs that load automatically and guide you through the installation. You can also refer to your OS user manual for instructions on formatting or partitioning the hard disk drive before any software installation.

The DISPLAY PAC-PPCsystem provides the following utility drivers stored in the CD-ROM diskette or utilities diskettes;

- ✧ Ethernet utilities
- ✧ VGA utilities
- ✧ Audio drivers
- ✧ Touch screen drivers



### **3. VERSATILE STANDING & MOUNTING OPTIONS**

The DISPLAY PAC-PPC is designed for universal standing and mounting to fit into various environmental applications. This chapter highlights the steps of different mounting options with graphical illustrations. Sections include

- ◆ Upright Desktop standing
- ◆ Angle free Desktop standing
- ◆ Other stand options
- ◆ Wall Mounting
- ◆ Panel Mounting

The DISPLAY PAC-PPCsystem comes with a versatile stand composing of one big pedestal and a small base. The following diagrams show the major parts that make up the DISPLAY PAC-PPCstand.

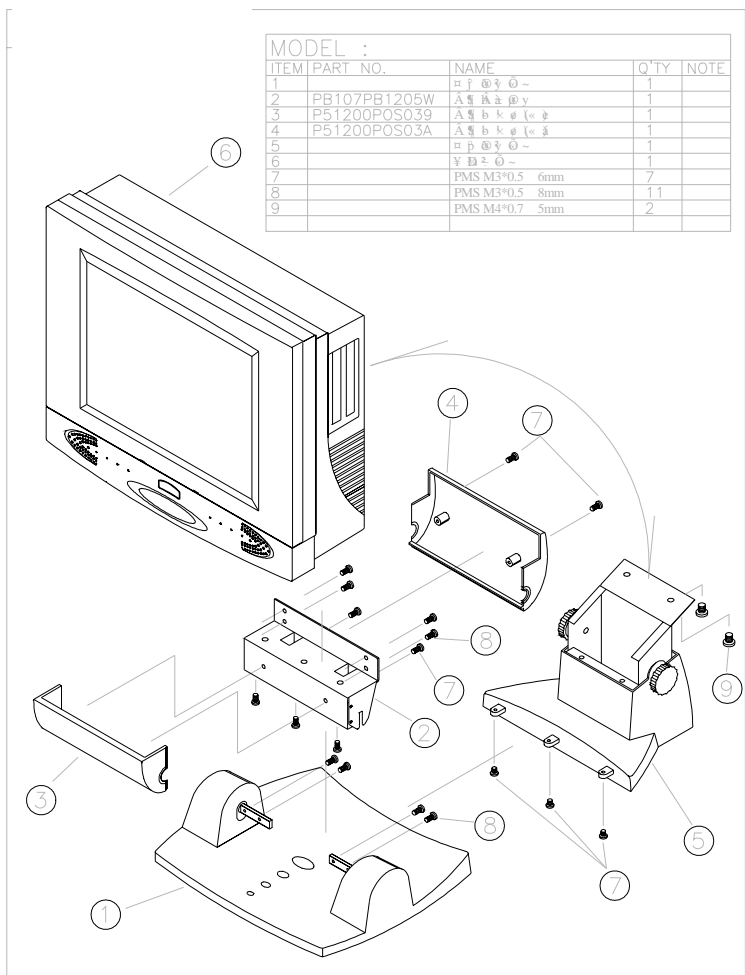

FIGURE 3-1: DISPLAY PAC-PPCSTAND A

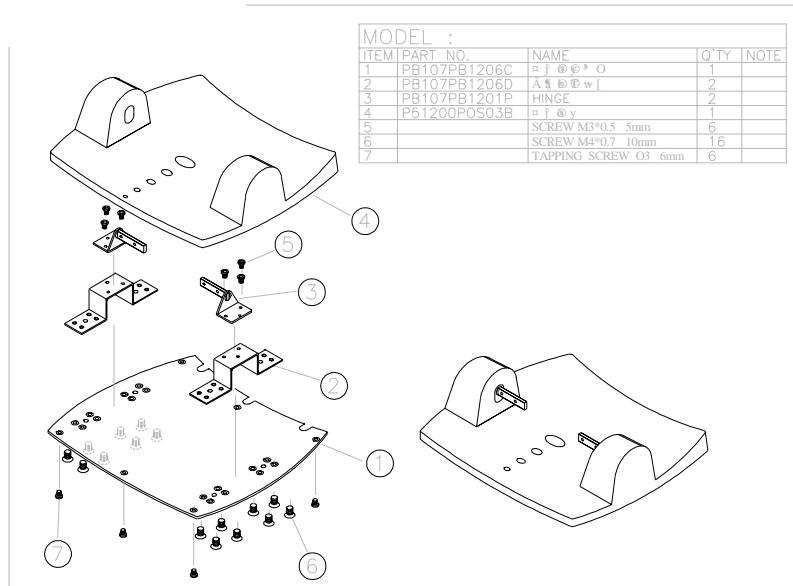

FIGURE 3-2: BIG PEDESTAL ASSEMBLY

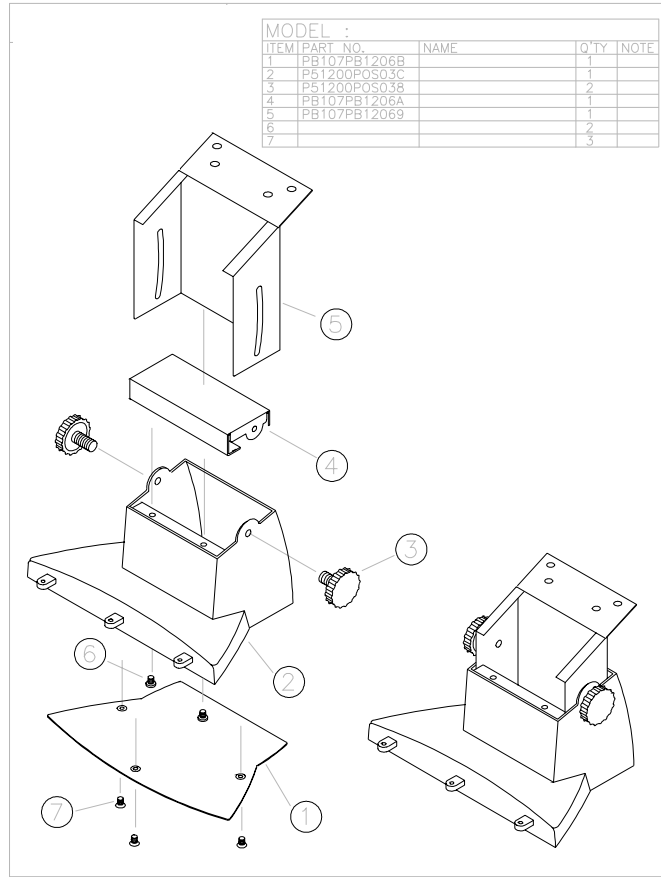

FIGURE 3-3: DISPLAY PAC-PPCSMALL BASE ASSEMBLY

### 3.1. Upright Desktop Standing

Compact in its size, all-in-one in its design along with its industrial-grade reliability, the DISPLAY PAC-PPC system standing upright is the best replacement for a desktop computer. When the DISPLAY PAC-PPC is to stand upright, only the big pedestal kit is needed.

Before assembly

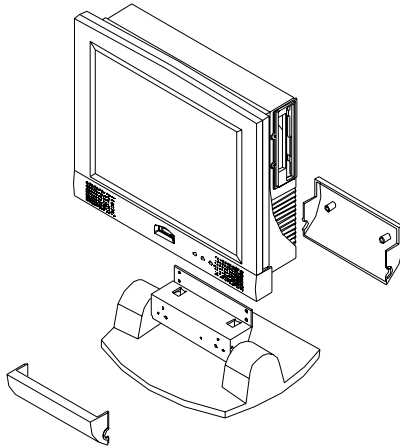

FIGURE 3-4

After assembly

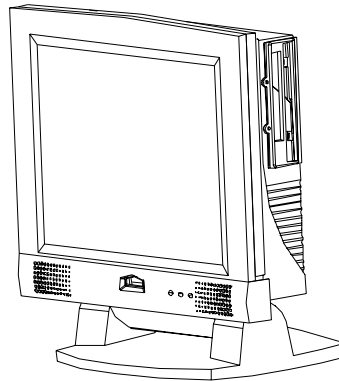

FIGURE 3-5

### 3.2. 30 to 47° Desktop Standing

The sleek and stable pedestal assembled with the small base enables the DISPLAY PAC-PPCsystem to endure the long-time operation in any public sectors. By swiveling the two knobs on the small base and pulling the base up and down, the angle can be adjusted from 30 to 47°.

Before assembly

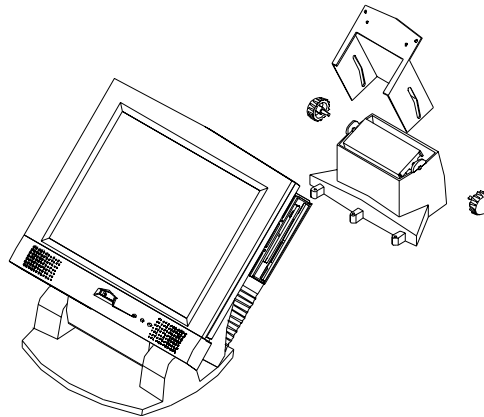

FIGURE 3-6

After assembly

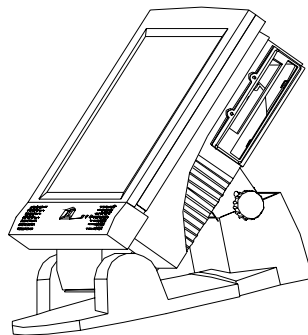

FIGURE 3-7

### 3.3. Other Stand Options

In addition to the standard stand, the DISPLAY PAC-PPC also provides different stand options for special environmental applications.

#### 3.3.1. 60 to 90° Desktop Standing

This stand is used when the DISPLAY PAC-PPC system is to stand upright while the touch screen is frequently used. The big pedestal assembled with a special small prop enables the DISPLAY PAC-PPC to stand from 60 to 90° by swiveling the two knobs on the back prop. The opening on the back prop can act as a cable management cutout. All the cables connecting to the I/O ports can come out from this cutout.



Cable management cutout.

FIGURE 3-8

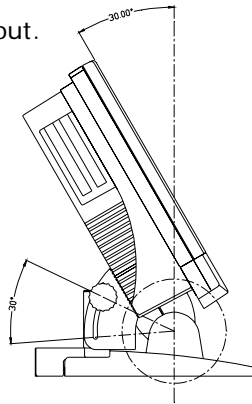

FIGURE 3-9

### **3.3.2. 80° Desktop Fixed Standing**

The DISPLAY PAC-PPC provides an optional iron base that enables the computer to be fixed to the table with screws for 80°.

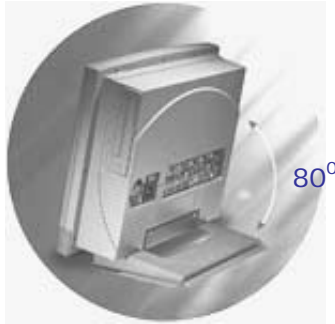

FIGURE 3-10

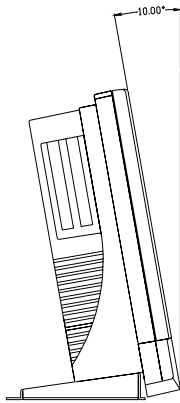

FIGURE 3-11

### 3.4. Wall Mounting and Mobile Applications

The DISPLAY PAC-PPCsystem provides 2 sets of VESA holes, 75\*75mm and 100\*100mm on the rear side of the chassis. System integrators can design their special wall mount brackets per the two sets of VESA holes or obtain market-available swing arms for wall mounting, table mounting or mobile applications.

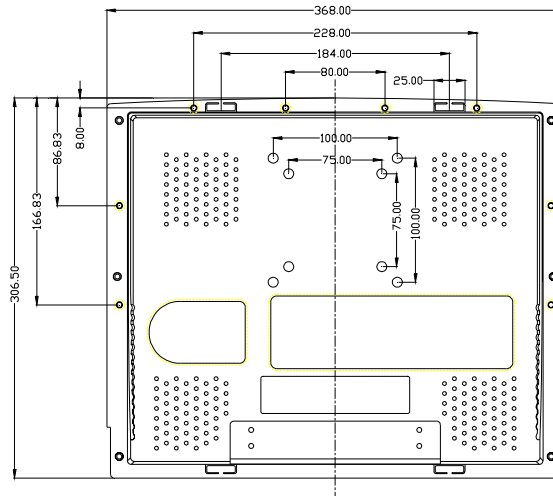

FIGURE 3-13: DISPLAY PAC-PPC 12.1" VESA



FIGURE 3-14



FIGURE 3-15

### 3.5. Panel Mounting

To use the DISPLAY PAC-PPCsystem in panel mount application, the 4 mounting holes on the upper side and the bottom side of the rear cover need to be cut through first. Then, use the 4 optional mounting brackets or design your own mounting brackets to mount the DISPLAY PAC-PPCsystem as shown on the figure below:

Before mounting

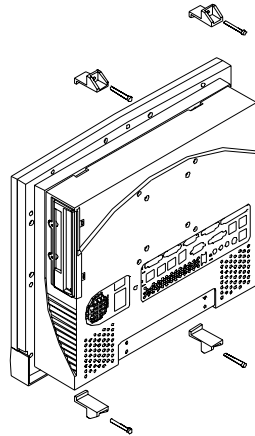

FIGURE 3-15

After mounting

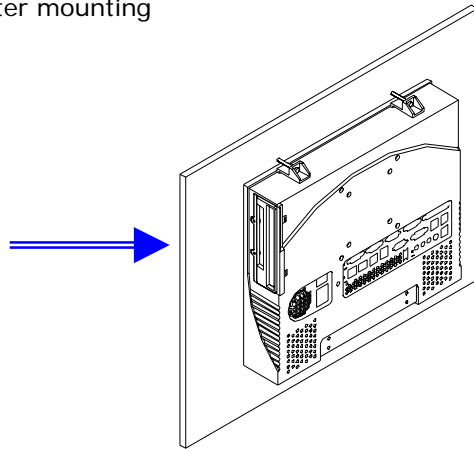

FIGURE 3-16

## **4. I/O CONNECTION**

This chapter describes the DISPLAY  
PAC-PPCsystem I/O ports and how to use the  
I/O interface to connect to external devices.

The I/O interfaces located at the back side of the chassis are used to connect external peripheral devices, such as a mouse, a keyboard, a monitor, serial devices or parallel printer...etc. Before any connection, make sure that the computer and the peripheral devices are turned off.

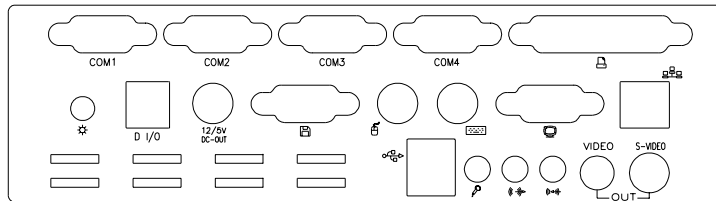

FIGURE 4-1

### 4.1. Parallel Port

The DISPLAY PAC-PPC can support the latest EPP and ECP parallel port protocols. It can be used to connect to a wide array of printers, ZIP drive, parallel scanner and any other parallel devices. The printer interface on the DISPLAY PAC-PPC is a 25-pin female D-SUB connector. To connect any parallel device, follow the steps below:

1. Turn off the system and the parallel devices.
2. Plug in the male connector of the parallel device to the 25-pin female D-SUB connector and fasten the retaining screws.
3. Turn on the system and the attached parallel devices.
4. Refer to the parallel device's manual for instruction to configure the operation environment to recognize the new attached devices.
5. You may need to run the CMOS setup to change the hardware device setup.

## 4.2. COM Ports x 4

The DISPLAY PAC-PPC features with four onboard COM ports located at the rear side of the chassis, ready to connect to a wide range of serial devices. COM1, COM3 and COM4 are RS-232 and COM2 is RS-232/485, selected via jumper setting. Each COM port is with +5V/+12V power capabilities on pin 9, providing easy accommodation to a broad range of serial devices.

The COM port 5V/12 power is selected via jumper setting on the IO-TR board. The IO-TR is the IO board docked to the system motherboard to connect the onboard signal out to the external I/O ports.

Please refer to the following for the 5V/12 power selection.

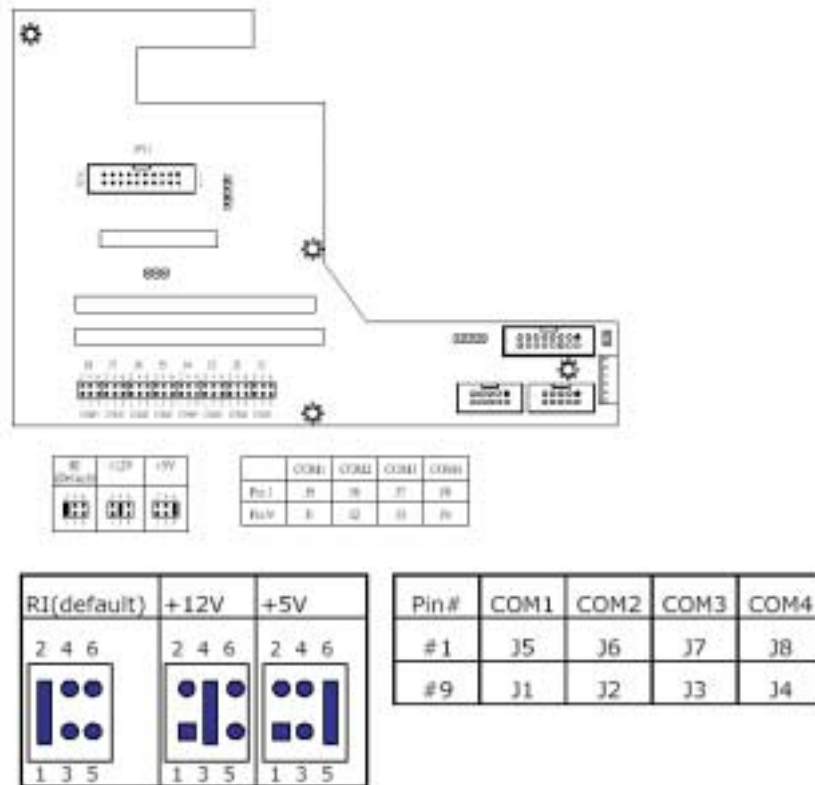

If a touch screen module is installed, for factory default setting, its controller will occupy COM3.

COM1 to COM4 are all D-SUB 9-pin connectors. To connect to any serial device; follow the procedures below;

1. Turn off the DISPLAY PAC-PPCsystem and the serial devices.
2. Attach the interface cable of the serial device to the 9-pin D-SUB serial connector. Be sure to fasten the retaining screws.
3. Turn on the computer and the attached serial devices.
4. Refer to the serial device's manual for instruction to configure the operation environment to recognize the new attached devices.
5. If the serial device needs specified IRQ or address, you may need to run the CMOS setup to change the hardware device setup.

If the COM2 is to be set to RS-485 for long distance transmission, the related onboard jumpers have to be set correctly first. Refer to section 6.2.1.2 for the RS-232/485 jumper settings and Appendix D for RS-485 programming.

### 4.3. 100/10 Base-T Ethernet (RJ-45)

The DISPLAY PAC-PPC provides a 100/10 Base-T NE2000 compatible Ethernet (RJ-45) interface. For network connection, follow the instructions below.

1. Turn of the DISPLAY PAC-PPCsystem and the Ethernet hubs.
2. Plug in one end of cable of a 100/10 Base-T hub to the system's RJ-45 phone jack. The pin assignment of the RJ-45 is listed as follow;

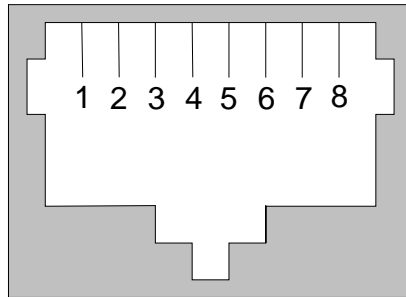

RJ-45

RJ-45 Connector Pin Assignment

Pin	Description
1	Tx+ (data transmission positive)
2	Tx- (data transmission negative)
3	Rx+ (data reception positive)
6	Rx- (data reception negative)
others	No use

#### **4.4. VGA Interface**

The DISPLAY PAC-PPC has a 15-pin analog RGB connector located at the rear side of the chassis. It can support its own LCD display and an expansion CRT or analog monitor at the same time. However, as the LCD panel used in the 15" system (DISPLAY PAC-PPC 15.1") is of the resolution of 1024 x 768 and in 12.1" system (DISPLAY PAC-PPC 12.1" ) is 800 x 600, therefore, to support a CRT or analog monitor simultaneously, the monitor's VGA resolution has to be set to 800 x 600 for DISPLAY PAC-PPC 12.1" and 1024 x 768 for DISPLAY PAC-PPC 15.1". The connection to an analog monitor is an easy plug-in of the VGA D-SUB 15-pin connector to the RGB interface.

There is some application software that is to be executed in 800\*600 resolution. When the software is running under DISPLAY PAC-PPC 15.1", only part of the screen will show on the LCD display. If the application has to run in full screen, you need to update the system VGA drivers with an auto expansion utility. However, due to resolution limitation, the text mode will look slightly distorted.

#### **4.5. PS/2 Keyboard Interface**

The DISPLAY PAC-PPC provides a standard PS/2 keyboard connector located at the rear panel. If the user would like to use AT keyboard, then an adapter to connect the PS/2 KB to AT KB is needed.

#### **4.6. PS/2 Mouse Interface**

The DISPLAY PAC-PPCsystem has one PS/2 mouse connector located at the rear side. A simple plug-in will make the connection.

### 4.7. External FDD (DB-15)

The DISPLAY PAC-PPC provides two ways to connect to a floppy disk drive to fit into specific environmental applications:

1. Internal FDD
2. External FDD

If the FDD is frequently used, it is suggested to use an internal floppy disk drive. If the drive is used only for system installation or maintenance, then, an external device can fulfill this need and is more economical. Please note that if an internal floppy disk drive already exists, no external floppy drive can be used.

The DISPLAY PAC-PPC external FDD interface is a 15-pin D-sub connector located at the rear side of the chassis. An external FDD cable is provided to connect a standard 3.5" FDD to the system. Its pin position and pin assignment are listed as follows.

Pin #	Signal	Pin #	Signal
1	DELSEL	9	-WD
2	-INDEX	10	-STEP
3	-MTR1	11	-RD
4	-DVR1	12	-HDSEL
5	-DIR	13	-DSKCHG
6	-WP	14	+5V
7	-TRKO	15	+12V
8	-WG		

The DISPLAY PAC-PPC(661) system is equipped with a +5V/12V DC-out connector to provide 5V power to drive the external floppy disk drive. Use the provided FDD power cable to connect the floppy drive to the 5V DC-out connector when an external floppy drive is attached

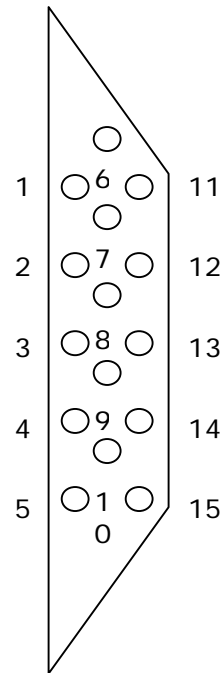

#### **4.8. +5V/12V DC-Out**

The DISPLAY PAC-PPCsystem provides a +5V/12V DC-out connector. It is used to provide necessary power source for some external devices. For example, if the DISPLAY PAC-PPCsystem is to be housed in a KIOSK cabinet which requests extra cooling fan for heat dispensing, then the fan power cable can be attached to 5V/12V DC-out to obtain power from the computer directly. If an external floppy disk drive is attached to the system, it will need +5V power source from the system. A power cable for the external floppy disk drive is already provided for this connection. For other devices, you might need to make your own power cable for the connection.

#### **4.9. VR Brightness Control**

The DISPLAY PAC-PPCsystem provides a VR control to adjust the brightness of the LCD. The VR control is with a "+" shape cutout on it. You will need a "+" shape screwdriver to adjust it for display brightness control.

## 4.10. DIO (Digital Input & Output)

The DISPLAY PAC-PPC provides 2-channel DIO that can be used for the system's simple automation control needs. The digital I/O can be configured to control the opening of a cash drawer or to sense the warning signal of an uninterrupted power system (UPS) or to do the store security control.

The DIO port address and pin definition is listed below;

I/O Port address: 206H

Read : SD0, SD1

Write : SD4, SD 5

DIO RJ-12

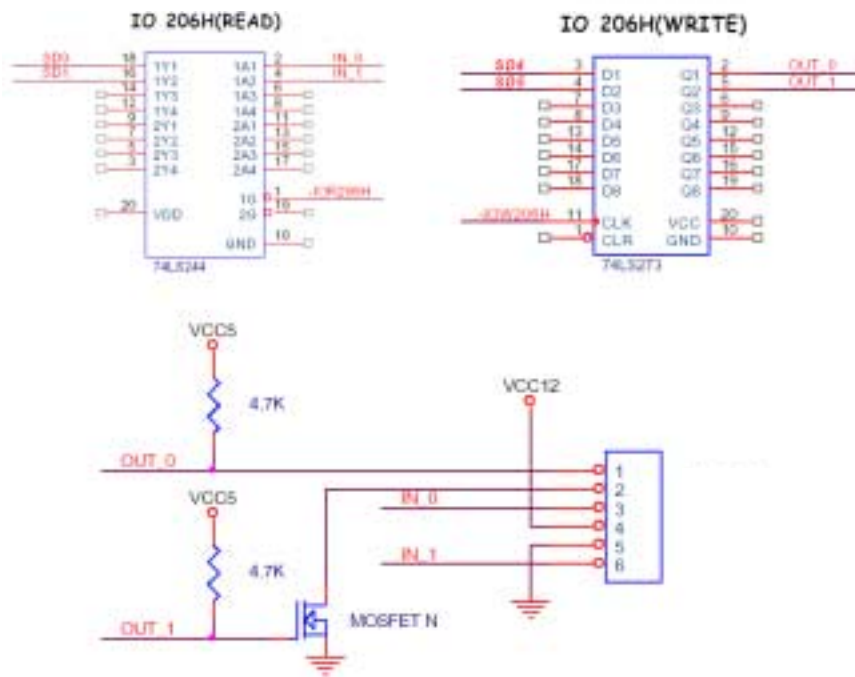
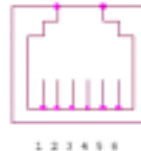

The Digital I/O is of TTL interface. It is controlled via software programming.

### **Digital I/O Programming**

Input/output address: 206H

EXAMPLE:

```
10 REM Digital I/O example program
20 X = INP (&H206)      REM INPUT Digital I/O port
                        for 4 bit
30 X = OUT (&H206)     REM OUTPUT Digital I/O port
                        for 4 bit
   ⋮
60 END
100 Return
Port 206H Definition
```

#### 4.11. TV-out Interface (Optional)

The TV-out interface supported by optional device with SiS301 Chipset contains two types of connectors, one S-terminal connector and the other RCA jack. The TV-out interface is used when the TV or NTSC/PAL monitor is used as the display monitor. Please note that either the TV or the LCD can be used as the display at a given time; they can not display images simultaneously.

Due to chipset limitation, when the TV monitor is used as the display, the graphic mode is viewable while the text is hardly legible.

To use the TV-out, the TV-out function in the BIOS setup needs to be activated first. If your application is running under Microsoft® Windows® environment, under Windows® *Control Panel*, you will see the following selections.

CRT  
LCD  
Both  
TV

The default setting is "*Both*". Click "TV" to activate the TV-out function.

#### **4.12. Audio Interface (Line-in, MIC-in, SPK-out)**

The audio interface contains three jacks, microphone-in, line-in and speaker-out.

The microphone-in jack is used to record sound or voice by connecting to an external microphone. The line-in jack is used to input audio from an external audio device such as a CD player, tape recorder or a radio. The speaker-out jack is to output the audio to external devices such as speakers or earphones. The audio device can be directly attached to the jacks. Please note that the audio driver has to be installed first before using any audio device.

#### **4.13. USB Ports**

The DISPLAY PAC-PPC also provides two USB ports to connect to external USB devices. A simple plug-in of the USB device interface cable to the USB port will make the connection. Before using the USB devices, remember to install the device driver first.

#### **4.14. AC/DC Inlet/Power Switch**

For DISPLAY PAC-PPC AC system, it can operate in the input range from 90 ~ 240 volts, 50 ~ 60 Hz). For DC system, the input range can be from 9 ~ 132VDC with different DC power supplies.

## 5. HARDWARE INSTALLATION AND UPGRADE

This chapter overviews the installation of the POSEIDON's internal components and devices. Sections include:

- ◆ The exploded diagram
- ◆ Touch screen & LCD assembly
- ◆ Power module assembly
- ◆ Installing the CPU
- ◆ Installing the SDRAM
- ◆ Installing the 3.5" HDD
- ◆ Installing the slim FDD
- ◆ Installing the compact CD/DVD-ROM
- ◆ Expansion slots

The DISPLAY PAC-PPC consists of a Celeron/ Pentium® III embedded mini board with an adequate CPU and relevant SDRAM on it. The system control board and other internal devices such as expansion card, HDD and power supply are already housed in a plastic rear cover. The system's performance depends on the installed CPU and the capacity of the system memory and hard disk drive. In some circumstances, you might intend to upgrade or maintain the system. By removing the rear cover and the metal covers, the internal components such as CPU, SDRAM, HDD, internal FDD, CD-ROM and power supply can be easily accessed for maintenance and upgrade.

## 5.1. Recognizing the System Major Parts

The following diagram shows the system major parts that make up the DISPLAY PAC-PPC .

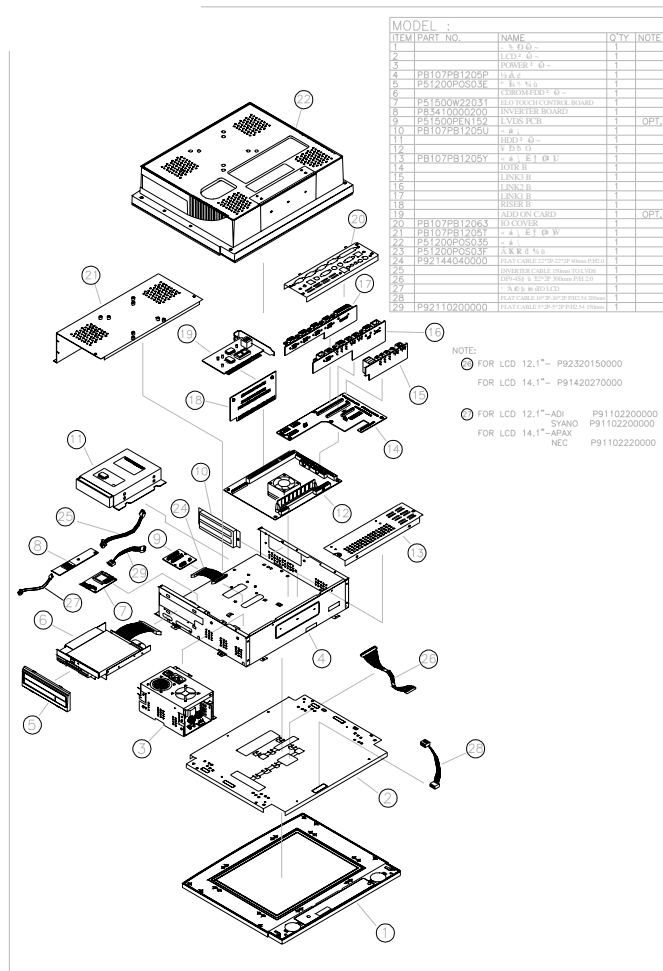

FIGURE 5-1: DISPLAY PAC-PPC EXPLODED

## 5.2. Touch screen Module Assembly

The following diagram shows the steps to assemble the touch screen to the front bezel. The assembly of DISPLAY PAC-PPC 12.1" front bezel differs from that of DISPLAY PAC-PPC 15.1" as the DISPLAY PAC-PPC 12.1" speaker cover (1) is a separate piece from the plastic front bezel while the DISPLAY PAC-PPC 15.1"s speaker cover is in one piece with the front bezel.

The DISPLAY PAC-PPC is able to accommodate Elo analog resistive touch or Intelli (SAW) touch screen. **PLEASE NOTE THAT WHEN DIFFERENT TOUCH MODULE IS INSTALLED, DIFFERENT TOUCH SCREEN METAL BRACKETS ARE NEEDED. YOU CAN NOT REPLACE ONE TYPE OF TOUCH PANEL WITH THE OTHER WITHOUT CHANGING THE TOUCH SCREEN METAL BRACKETS USED TO HOLD THE TOUCH PANEL TO THE FRONT BEZEL.**

If no touch screen is installed, a resilient glass is to be assembled instead.

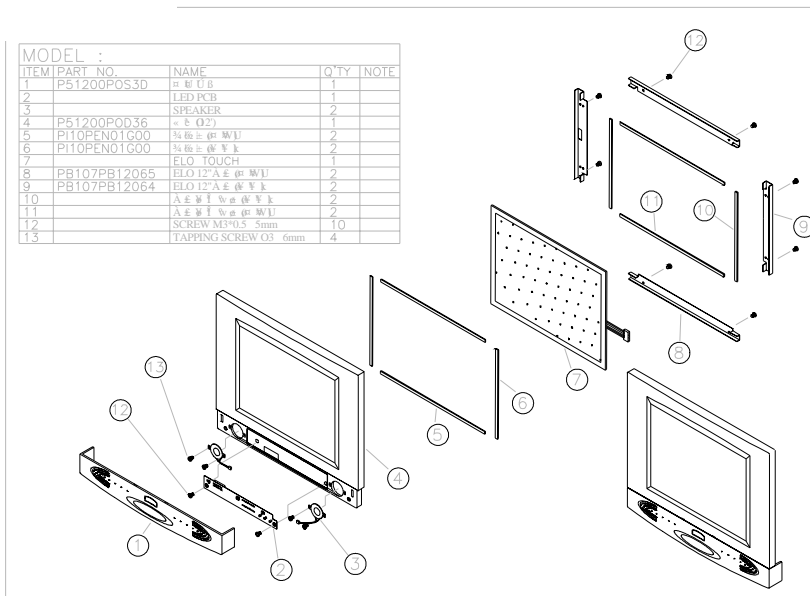

FIGURE 5-2: DISPLAY PAC-PPC 12.1" FRONT BEZEL

### 5.3. LCD Module Assembly

The following diagram shows the way to assemble the LCD module. The assembly of DISPLAY PAC-PPC 12.1" LCD module differs from DISPLAY PAC-PPC 15.1".

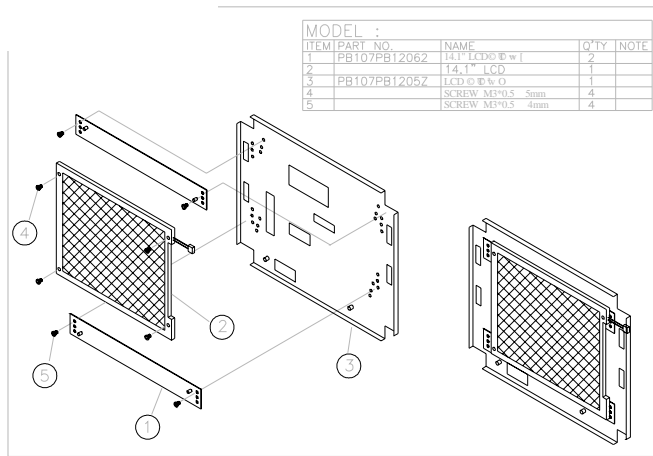

FIGURE 5-3: **DISPLAY PAC-PPC 12.1" LCD MODULE**

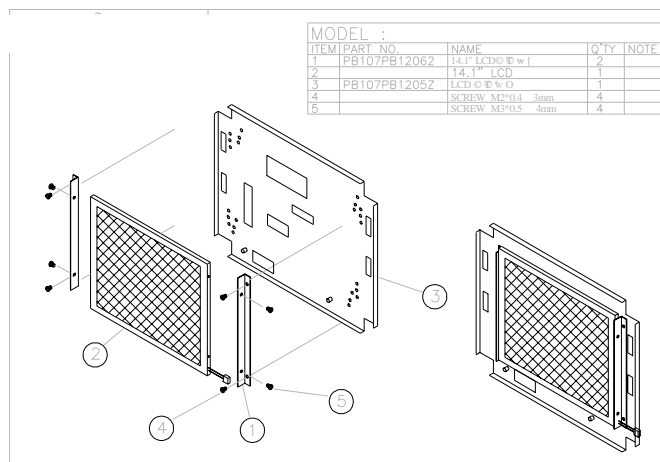

FIGURE 5-4: **DISPLAY PAC-PPC 15.1" LCD MODULE**

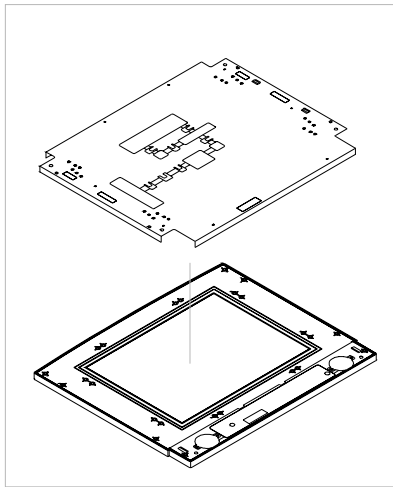

FIGURE 5-5: LCD MODULE TO FRONT BEZEL

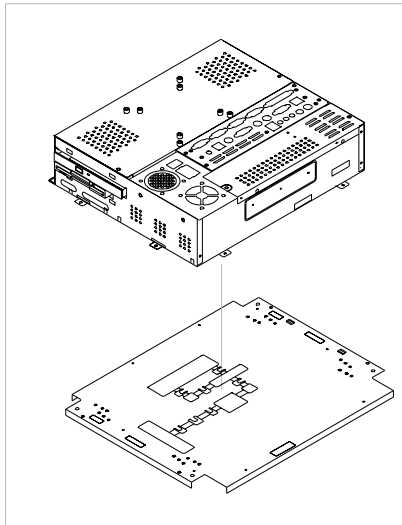

FIGURE 5-6: LCD MODULE TO MAIN SYSTEM

### 5.4. Power Module Assembly

The following diagram shows the steps to assemble the AC power module. For the specification of the power supply, please refer to APPENDIX G.

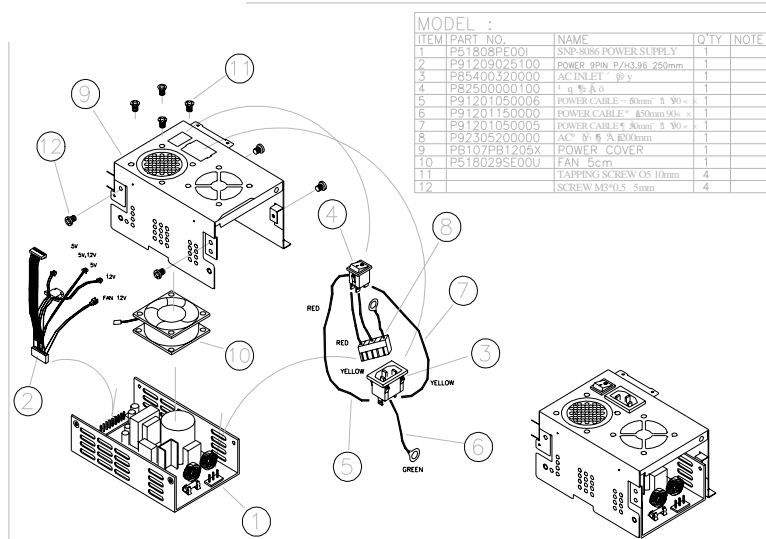

FIGURE 5-7: DISPLAY PAC-PPCAC POWER MODULE

## 5.5. Installing the CPU

The DISPLAY PAC-PPC system control board can adapt Intel® Celeron® and Pentium® III CPU. It can support Intel Socket 370 CPU from Celeron® PPGA/FCPGA/ 66MHz to Pentium® III FCPGA/133MHz (SiS630ST).

The system controller provides one 370-pin socket (Socket 370). The CPU must come with a CPU fan to avoid overheating. The Celeron CPU and Pentium III CPU will request different kinds of CPU fans due the difference on the CPUs' mechanism. Wrong fans might lead to overheating for the entire system. To install a CPU or upgrade a new CPU, follow the instructions below.

1. If there is an existing CPU on the socket, remove the CPU first by pulling the lever out a little and raising it, then lifting out the existing CPU from the socket.
2. To insert the CPU into the socket, the notch on the corner of the CPU (the corner with white dot) should point toward the end of the socket lever. If the insertion of the CPU to the socket is not easy, check whether the CPU pins correspond with the holes on the socket.
3. After insert the CPU into the socket, pull the lever down to make sure the CPU is in place.
4. The CPU cooling fan comes with a 3-pin power cable. Connect the power cable to the 3-pin power connector on the motherboard.
5. There are two small white clips on the CPU sockets. Make sure the cooling CPU fan clips click into place.

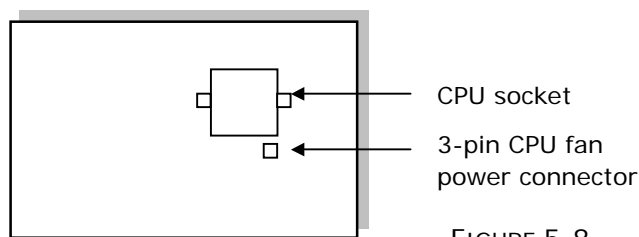

FIGURE 5-8

## **5.6. Installing the SDRAM Memory Module**

The DISPLAY PAC-PPC system control board provides 1 x 168-pin DIMM socket, able to support SDRAM memory from 64MB up to 512MB. To install the memory module, follow the instructions below.

1. Find the 168 pin DIMM socket on the motherboard
2. There are two white eject levers at each end of the DIMM socket. Push them outward until they separate from the two vertical posts.
3. Holding the memory module with the notch on the upper right corner, then insert the memory module into the DIMM socket at 90° angle.
4. Push the two eject levers toward the vertical posts until they click into place. The memory module is now upright.

The system is able to auto detect the new memory size and there is no need to change the system configuration after installation.

Make sure that the memory module you are using can handle the specified SDRAM MHz. Inadequate memory module will make the computer unable to boot up.

## **5.7. Installing the HDD**

The DISPLAY PAC-PPC provides enough space to build in a 3.5" hard disk drive in the system compartment.

If the user intends to attach a hard disk or remove the existing device, the following steps shows the way to install an internal hard disk drive.

1. Detach and remove the rear cover. Remove the system metal cover located at the upper side of the chassis.
2. Invert the system compartment to make the upper side of the chassis to be lower side.
3. Now, from your point of view, the 3.5" HDD module is located at the left bottom side of the system compartment. Detach the existing 3.5" HDD module from the system chassis by removing the screw located at the left side of the chassis.
4. Refer to figure 5-9. Remove the existing hard drive from the HDD metal bracket (3).
5. Insert the HDD (1) and fix it to the metal bracket with 4 screws. Be sure to use the *SHORT*, round-head screws provided by the HDD makers.
6. Insert the HDD module back to the chassis and fix it with the screw located at the chassis side.
7. Connect the 4 pin power cable to the hard disk drive
8. Connect the 40-pin IDE cable (2) to hard disk drive. Make sure the other end of the cable is already connected to the motherboard secondary IDE connector.

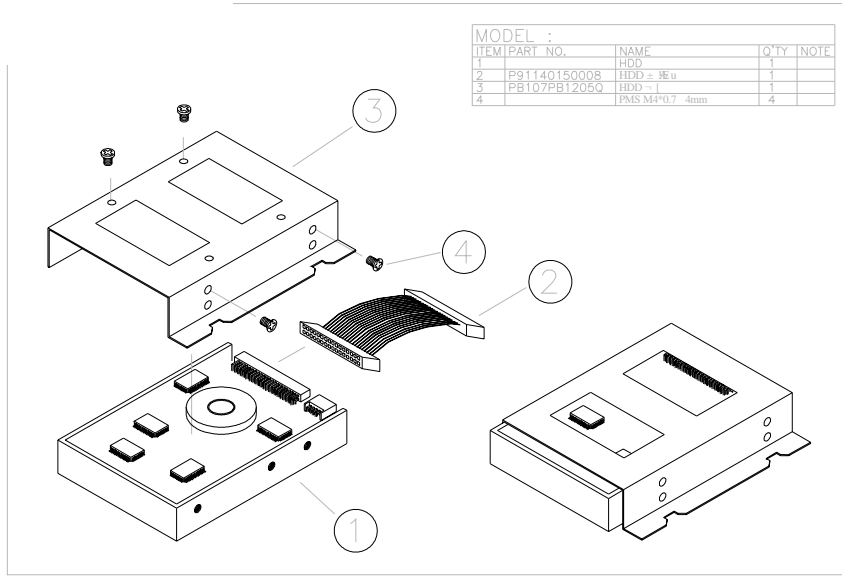

FIGURE 5-9: HDD INSTALLATION

## **5.8. Installing the FDD**

The DISPLAY PAC-PPC can connect to an external floppy disk drive or an internal floppy disk drive, depending on the system requirement.

Please note that either an external floppy disk drive or internal floppy disk drive can be used.

### **5.8.1. External FDD connection**

1. Use the provided 15-34 pin FDD cable (see below figure) to connect to the system's 15-pin FDD D-sub connector located at the rear side of the cover.



FDD cable

2. Connect the other end (34 pin) of the FDD cable to a standard 3.5" FDD. Match pin 1 of the FDD and pin 1 of the cable.
3. To drive the floppy disk drive, it will need 5V power. Connect the provided FDD power cable to the floppy disk drive to the +5V/12V DC-out connector to obtain 5V power for the device.

### 5.8.2. Internal FDD installation

Due to space limitation, when the DISPLAY PAC-PPC is installed with an internal floppy disk drive, only a slim type floppy disk drive can be used. The following steps show the ways to install an internal FDD.

1. Detach and remove the rear cover. Remove the system metal cover located at the upper side of the chassis.
2. Invert the system compartment to make the upper side of the chassis to be lower side.
3. Now, from your point of view, the FDD module is located at the right bottom side of the system compartment.
4. Take out the plastic FDD/CD-ROM cover at the right side of the chassis first. Remove the two screws used to fix the module to the chassis. Then, the FDD/CD-ROM module will slide out of the chassis from the FDD/CD-ROM opening.
5. Refer to Figure 5-10. Attach one end of the 26-pin FDD flat cable (3) to the slim floppy disk drive connector (2) first. Match pin 1 of the floppy disk drive and pin 1 of the cable.
6. Place the floppy disk drive to the bracket (1). Fix it on the bracket with the 4 screws.

There are two conditions.

- A. *No CD-ROM* is to be accommodated to the system. Refer to Figure 5-10 for reference.
  - 1). Fix the FDD/CD-ROM board (4) to the FDD bracket (9).
  - 2). Then, fix the FDD bracket with FDD/CD-ROM board to the FDD/CD-ROM bracket (1).
  - 3). Connect the other end of the 26-pin FDD cable (3) to the 26-pin connector on the FDD/CD-ROM board (4).

If a CD-ROM is to be accommodated to the system, no FDD bracket (9) is needed for the installation. Refer to Section 5.9 for the CD-ROM installation procedure.

After the FDD or FDD/CD-ROM module is properly installed,

7. Insert the whole unit to the system compartment from the CD-ROM/FDD opening. Fix it to the system chassis with two screws.
8. Cut out the plastic slips on the FDD/CD-ROM plastic cover to make openings for the insertion and ejection of the floppy disk and CD diskette. Click the plastic cover into place to the chassis.
9. Make sure the CD-ROM cable, 16-pin FDD cable, 4 pin audio cable and 5V power cable is properly connected to all the connectors on the FDD/CD-ROM board.

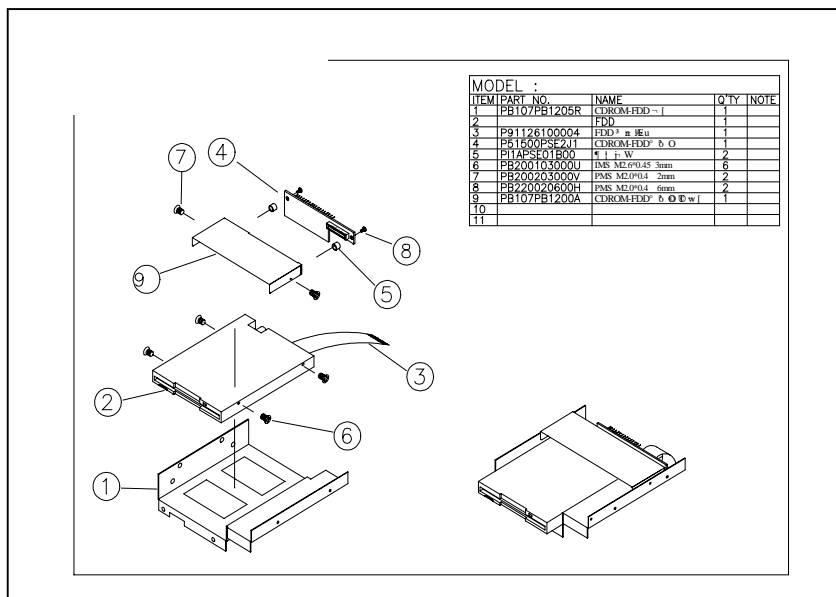

FIGURE 5-10: FDD INSTALLTION

## 5.9. Installing the CD-ROM or DVD-ROM

The CD-ROM or DVD-ROM drive used in the DISPLAY PAC-PPC is not the common 5.25" drive seen in computer stores. Rather, it is a slim type drive widely used in notebook computers. The following steps show the ways to install an internal CD-ROM or DVD-ROM.

1. Detach and remove the rear cover. Remove the system metal cover located at the upper side of the chassis.
2. Invert the system compartment to make the upper side of the chassis to be lower side.
3. Now, from your point of view, the FDD/CD-ROM module is located at the right bottom side of the system compartment.
4. Take out the plastic FDD/CD-ROM cover at the right side of the chassis first. Remove the two screws used to fix the module to the chassis. Then, the FDD/CD-ROM module will slide out of the chassis from the FDD/CD-ROM opening.
5. Refer to figure 5-12. If a floppy drive is to be installed, too, fix the FDD (2) with cable (3) to the FDD/CD-ROM metal bracket (1) first.
6. Attach the FDD/CD-ROM board (6) to the slim CD-ROM drive (4). *PLEASE NOTE THAT THE 2 SCREWS NEED TO BE INCASED WITH 2 PLASTIC WASHERS (7).*
7. Fix the small CD-ROM bracket (5) to the CD-ROM drive. This small bracket is to prevent the CD-ROM unit from moving when installed to the FDD/CD-ROM (1).
8. Place the CD-ROM unit on the FDD/CD-ROM bracket. Fix the unit on the bracket with the 2 screws.
9. Insert the whole unit to the system compartment from the CD-ROM/FDD opening.
10. Cut out the plastic slips on the FDD/CD-ROM plastic cover to make openings for the insertion and ejection of the floppy disk and CD diskette. Click the plastic cover into place to the chassis.

11. Connect the 44 pin-IDE cable (8) to the 44 pin IDE connector on the FDD/CD-ROM board. Make sure the other end of the cable is connector the motherboard primary IDE connector.
12. Make sure the 26 pin FDD flat cable, 16 pin FDD cable, 4 pin audio cable and 5V power cable is properly connected to all the connectors on the FDD/CD-ROM board.

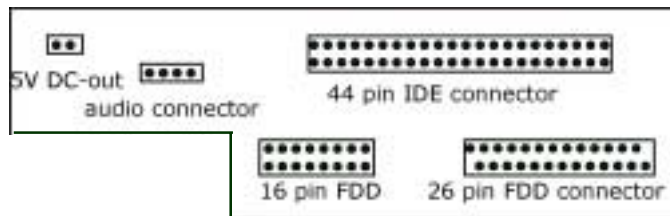

FIGURE 5-11: FDD/CD-ROM BOARD

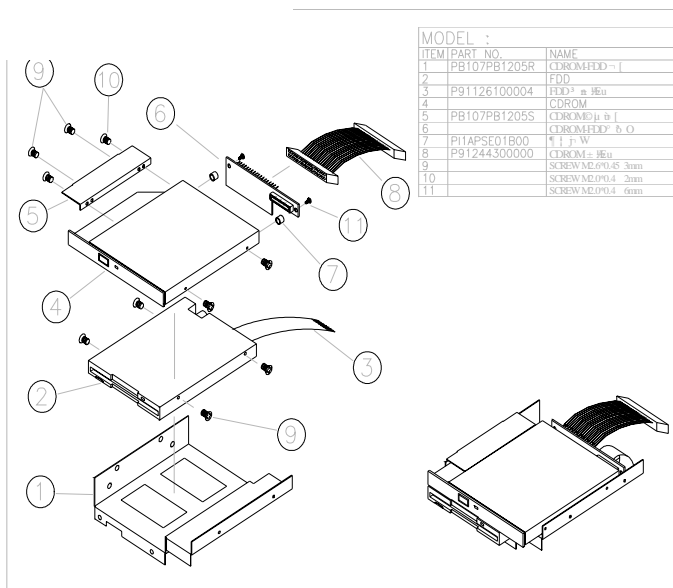

FIGURE 5-12: FDD/CD-ROM INSTALLATION

## Expansion Slots

The DISPLAY PAC-PPC provides PCI/ISA expansion slots for system expansion. Via the specially designed riser card, the system can accommodate either two PCI or one ISA and one PCI expansion cards.

Due to the internal space limitation, there is card size limitation.

If PCI expansion cards are used, the card size cannot exceed the following.

1<sup>st</sup> PCI card: 290\*120 mm (L\*W)

2<sup>nd</sup> PCI card: 160\*120 mm (L\*W)

If one PCI and one ISA expansion cards are used, the card size cannot exceed the following.

PCI card: 240\*120 mm (L\*W)

ISA card: 160\*120 mm (L\*W)

To use the PCI or ISA expansion, follow these instructions below.

1. Detach and remove the rear cover. Remove the system metal cover located at the upper side of the chassis.
2. Invert the system compartment to make the upper side of the chassis to be lower side.
3. Now, from your point of view, the riser card is located at the left bottom side of the system compartment.
4. Unscrew the 2 metal slips located inside the expansion outlet.
5. Plug the expansion cards into the ISA or PCI slot on the riser card and fix the expansion card by screwing it to the metal expansion frame. All the connectors of the expansion card will come out from the expansion outlet on the left side of the chassis for further cable connection.





## **6. SYSTEM CONTROL BOARD**

The system controller used in the DISPLAY PAC-PPCsystem is a Celeron/Pentium® III multimedia embedded little board, PC 661. This chapter provides detail introduction of the system engine.

## **6.1. Introduction**

This section provides background information and detail specification on the DISPLAY PAC-PPC system engine, PC 661. Sections include:

- ✧ General Information
- ✧ Features
- ✧ Specification
- ✧ Board placement & Dimension

### **6.1.1. General Information**

The **PC 661** is an Intel Celeron/ Pentium® III (Socket 370) multimedia mini board. Compact in size and with its highly integrated multimedia and networking functions, the PC 661 is the most powerful PC engine to build any small footprint all-in-one PC system for integration into any space-constricted embedded applications. Highly integrated, the PC 661 can adapt Intel® Celeron (66/100MHz), Pentium III (100/133MHz) and Tualatin CPU. Onboard features include super I/Os, XGA, LCD interface, IrDA, 10/100 Base-T Ethernet and audio functions. The full PC functionality coupled with its multi-I/Os stand ready to accommodate a wide range of PC peripherals. Special industrial feature not commonly seen in commercial systems such as watchdog timer makes the PC 661 the best choice for the operation in any hostile environments.

Fully configurable and with its modular design, the PC 661 is an ideal platform for any consumer computing applications where space is a premium.

### **6.1.2. Features**

- ◆ Compact profile for small-footprint system
- ◆ All-in-one design gets rid of compatibility and reliability problem that go with commercial motherboard
- ◆ Highly integrated design simplifies system integration and reduces system cost
- ◆ Multi-I/O design for accommodation of many PC peripherals
- ◆ Highly integrated multimedia functions
- ◆ High resolution for multimedia application
- ◆ Full networking and IrDA functions for convenient data transmission
- ◆ Modular design makes customization easy
- ◆ Providing PCI/ISA expansion slot for system future expansion
- ◆ Rugged industrial-grade construction allows system operation in any hostile environment
- ◆ Long product life cycle

### 6.1.3. Specifications

**PC 661:** Multimedia Intel Celeron/Pentium® III Embedded Mini Board with XGA, Flat panel, Ethernet & Audio Interface

- ◆ **CPU:** Intel Celeron/Pentium® III (Socket 370)
  - ◆ Intel Tualatin FCPGA2 up to 1.26GHz
  - ◆ Intel Pentium III FCPGA 100/133 up to 1GHz
  - ◆ Celeron FCPGA 66/100 up to 1.2GHz
- ◆ **System Chipset:** SiS630ST chipset
- ◆ **System BIOS:** Award PnP Flash BIOS
- ◆ **System Memory:** Equipped with one DIMM socket to support (32MB, 64MB, 128MB, 256, 512MB) 168-pin 3.3V SDRAM SPD (Special Presence Detect).
- ◆ **CPU built-in L2 Cache:** On chip 128KB Pipeline Burst Level 2 cache in the Socket 370 cartridge.
- ◆ **Flash Disk:** Support M-Systems DiskOnChip® (32 pin DIP socket).
- ◆ **Standard I/O**
  - Serial ports x 4: RS-232 x 3, RS-232/485 x 1 (COM2), jumper selectable
  - Parallel port x 1: Support SPP/EPP/ECP
  - Enhanced ATA 100/66 IDE Interface x 2
  - FDD Interface x 1
  - PS/2 Keyboard Interface x 1
  - PS/2 Mouse Interface x 1
  - USB Interface x 2
- ◆ **TTL Digital I/O:** Input x4, output x4

- ◆ **Watchdog Timer:** 64 level time intervals
- ◆ **Green Function:** APM 1.1 compliant
- ◆ **Expansion Bus:** PCI/ISA expansion slot x 1
- ◆ **Ethernet Interface**
  - SiS630ST chipset integrated
  - 10/100 Base-T Interface auto switch
  - NE2000 compatible
- ◆ **Display**
  - Integrating VGA/LCD/Controller, advance hardware 2D/3D GUI engine Share System Memory Architecture which can flexibly utilize the frame buffer size up to 64MB)
- ◆ **Audio Function**
  - **Chipset:** AC'97 Audio code controller
  - **Stereo sound:** full-duplex, integrated 3D audio
  - **Audio Interface:** Line-In, Speaker-Out, Mic-In and CD audio-in
- ◆ **Infrared Transceiver:**

Supports IrDA version 1.0 SIR protocol (Reserved)
- ◆ **Power Consumption:**

Single +5V operation @7A  
+12V operation @1A
- ◆ **Dimensions:** 146 x 203 mm

*Specifications are subject to change without notice.*

### 6.1.4. Board Placement & Dimension

The PC 661 dimension and layout is shown below;

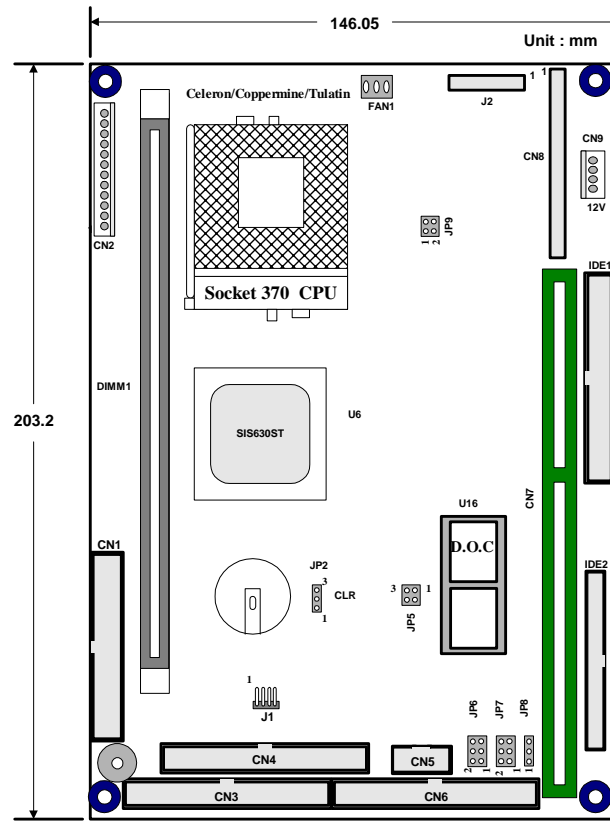

CN1: FLOPPY CON	J2:VGA For A/D	JP7: 3-5,4-6 RS232
CN2: POWER CON	JP9: Reserved	1-3,2-4 RS485
CN3: USB/KB/MS/PRINT OUTPUT	JP2: 1-2 CLR CMOS	JP6: 3-5,4-6 RS232
CN4: VGA/TV/AUDIO/LAN OUTPUT	2-3 SAVE CMOS	1-3,2-4 RS485
CN5: D I/O OUTPUT	JP5: D.O.C Address Setting	IDE1: ATA66/100 40P 2.54mm
CN6: COM 1-4/IR OUTPUT	1-2 D800	IDE2:ATA33 44P 2.0mm
CN7: PCI/ISA SLOT	3-4 D000	
CN8: LCD OUTPUT	JP8: 1-2 RS232	
CN9:LCD BACKLIGHT	3-4 RS485	
J1:CD AUDIO		

### **6.1.5. Jumpers & Jumper Setting**

The table below lists the function of each jumper. The related jumper settings are shown in the coming sections.

<b>Jumper</b>	<b>Description</b>
<b>J1</b>	CD Audio Input Connector
<b>J2</b>	VGA For A/D Board
<b>JP4</b>	CMOS clear
<b>JP5</b>	DickOnChip 2000 address Setting
<b>JP6</b>	COM2 RS-232/485 selection
<b>JP7</b>	COM2 RS-232/485 selection
<b>JP8</b>	COM2 RS-232/485 selection
<b>JP9</b>	Reserved

6.1.5.1. J1: CD Audio Input Connector

Pin #	Signal
1	AUXL
2	GND
3	GND
4	AUXR

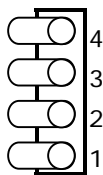

6.1.5.2. J2: VGA Interface Connector for A/D Board

The PC 661 provides a VGA interface connector (J2) to support A/D Board use. Its pin assignment is listed below;

Pin #	Signal	Pin #	Signal
1	GND	2	GND
3	BOUT	4	GND
5	GND	6	GND
7	GOUT	8	GND
9	GND	10	DDC1DATA
11	ROUT	12	DDC1CLK
13	HSYNC	14	VSYNC

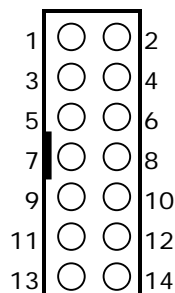

6.1.5.3. CMOS Clear Setting (JP2)

Before setting "CMOS Clear", remember wer  
 supply to avoid damaging the compute  
 setting, before turning on the power supply, set the jumper  
 back to "3.6V Battery on".

JP4: CMOS Clear Setting

3.6V Battery On

Clear CMOS



default setting

6.1.5.4. DOC 2000 Address Setting (JP5)

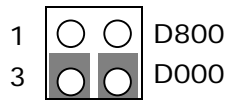

Address D000~D7FF

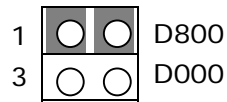

Address D800~DFFF

6.1.5.5. COM 2 RS-232/485 Setting (JP6, 7, 8)

The PC 661 is a RS-232/485 serial port. JP6, JP7 and JP8 determine the specific port type.

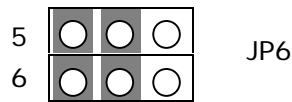
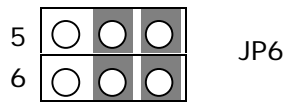
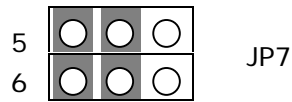
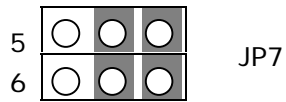

RS-485 mode

RS-232 mode

The RS-485 is software programmable. Please refer to APENDIX for the programming.

### **6.1.6. Connectors & Pin Assignment**

The table below lists the function of each connector on the PC 661. Their corresponding pin assignments will be shown in the following sections.

<b>Connector</b>	<b>Description</b>
CN1	FDD Connector
CN2	Main Power Connector
CN3	PS/2 Keyboard, PS/2 Mouse, USB and Parallel Port Connector
CN4	Audio, Ethernet 10/100 Base-T, VGA Connector
CN5	Digital I/O Connector
CN6	IR and Serial Port Connector Video Interface Connector
CN7	PCI/ISA Expansion Slot
CN8	Flat Panel Connector
CN9	LCD Backlight Connector
IDE1	Primary IDE Connector (40 pin)
IDE 2	Secondary IDE Connector (44 pin)

6.1.6.1. CN1: FDD Connector

The CN1 is a 34-pin pin header FDD connector. Its pin table is shown below;

CN1: FDD Connector Pin Assignment

Pin #	Signal	Pin #	Signal
1	GND	2	RWC
3	GND	4	NC
5	GND	6	NC
7	GND	8	INDEX #
9	GND	10	MTRO#
11	GND	12	DRV1#
13	GND	14	DRVO#
15	GND	16	MTR1#
17	GND	18	DIR#
19	GND	20	STEP#
21	GND	22	WD#
23	GND	24	WG#
25	GND	26	TRK0#
27	GND	28	WP#
29	GND	30	RD#
31	GND	32	HDSEL#
33	GND	34	DSKCHG#

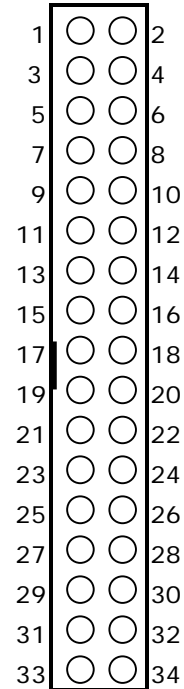

6.1.6.2. FAN1: FAN Connector

FAN1

Pin #	Signal
1	FAN Controller
2	+12V
3	GND

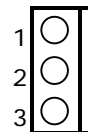

6.1.6.3. CN2: Main Power Connector

CN2 is a main power connector. Its pin assignments are listed below:

CN12: Main Power Connector

Pin #	Signal
1	GND
2	NC
3	GND
4	+12V
5	GND
6	GND
7	GND
8	+5V
9	+5V
10	+5V
11	+5V
12	NC or (SB5V by ATX power)

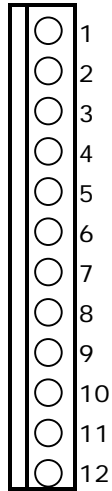

6.1.6.4. CN3: KB, MS, USB & LPT Connector

The PC 661 provides one keyboard port, one PS/2 mouse port, two USB ports and one parallel port with their signal mixed in the CN3 connector.

CN3: Keyboard, Mouse, USB & LPT Ports

Pin #	Signal	Pin #	Signal
1	+5V	2	+5V
3	USBDAT0-	4	USBDAT1-
5	USBDAT0+	6	USBDAT1+
7	GND	8	GND
9	+12V	10	+12V
11	GND	12	GND
13	PS2MDAT	14	PS2KDAT
15	PS2MCLK	16	<b>PS2KCLK</b>
17	<b>+5V</b>	18	+5V
19	<b>PWRBTN#</b>	20	NC
21	<b>GND</b>	22	GND
23	GND	24	DATA7
25	SLCTIN	26	DATA6
27	INIT	28	DATA5
29	ERROR	30	DATA4
31	AUTOFD	32	DATA3
33	SLCT	34	DATA2
35	PE	36	DATA1
37	BUSY	38	DATA0
39	ACK	40	STORBE

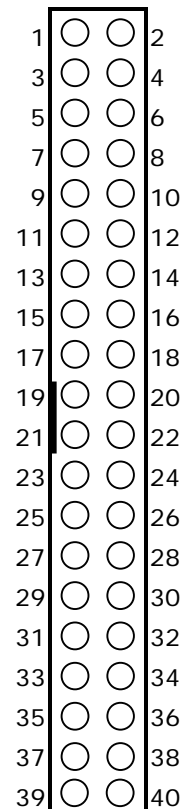

6.1.6.5. CN4: Audio, Ethernet VGA CRT & LED Connector

The CN4 is a 40-pin, dual-in-line pin header providing signals for audio, VGA CRT, Ethernet and LED.

CN4: Audio, VGA CRT, Ethernet and LED

Pin #	Signal	Pin #	Signal
1	+5V	2	+5V
3	HDDLED	4	RESET
5	NC	6	LANLINK-LED
7	GND	8	LAN/RX-LED
9	GND	10	GND
11	GND	12	+5V
13	VSYNC	14	HSYNC
15	RED	16	GRN
17	BLUE	18	VGADDA
19	VGADCK	20	GND
21	CROMA	22	LUMA
23	COMP	24	GND
25	GND	26	GND
27	GND	28	MIC-IN
29	AUDIO-L	30	AUIDO-R
31	LINE IN-L	32	LINE IN-R
33	SPKRDAT	34	+5V
35	LANGND	36	TX+
37	TX-	38	RX+
39	RX-	40	LANGND

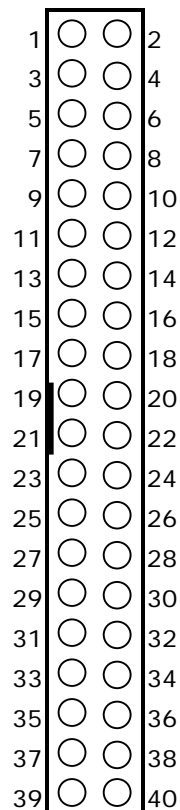

6.1.6.6. CN5: Digital I/O Connector

The CN5 is a 10 pin digital I/O connector.

CN5: DIO Connector pin assignment

Pin #	Signal	Pin #	Signal
1	OUT DATA0	2	IN DATA0
3	OUT DATA1	4	IN DATA1
5	OUT DATA2	6	IN DATA2
7	OUT DATA3	8	IN DATA3
9	GND	10	GND

The PC 661 DIO can be used for the system's simple automation control needs. The digital I/O can be configured to control the opening of a cash drawer or to sense the warning signal of an Uninterrupted Power System (UPS) or to do the store security control.

The Digital I/O is of TTL interface. It is controlled via software programming;

**Digital I/O Programming**

Input/output address: 206H

EXAMPLE:

```

11  REM Digital I/O example program
21  X = INP (&H206)      REM INPUT Digital I/O port
                           for 4 bit
30  X = OUT (&H206)     REM OUTPUT Digital I/O port
                           for 4 bit
   ..
61  END
101 Return
    
```

Port 206H Definition

6.1.6.7. CN6: IR and Serial Ports Connector

The CN6 is a 40-pin IR and serial port connector. The PC 661 provides one IR port and four onboard serial ports with their signals mixed in one connector, CN6. The following table shows the related pin signals;

CN6: IR Port and 4 COM Ports

Pin #	Signal	Pin #	Signal
1	DCD1	2	DSR1
3	RX1	4	RTS1
5	TX1	6	CTS1
7	DTR1	8	RI1
9	GND	10	GND
11	DCD2	12	DSR2
13	RX2	14	RTS2
15	TX2	16	CTS2
17	DTR2	18	RI2
19	GND	20	GND
21	DCD3	22	DSR3
23	RX3	24	RTS3
25	TX3	26	CTS3
27	DTR3	28	RI3
29	IRVCC5	30	IRVCC5
31	DCD4	32	DSR4
33	RX4	34	RTS4
35	TX4	36	CTS4
37	DTR4	38	RI4
39	IRTX2	40	IRRX2

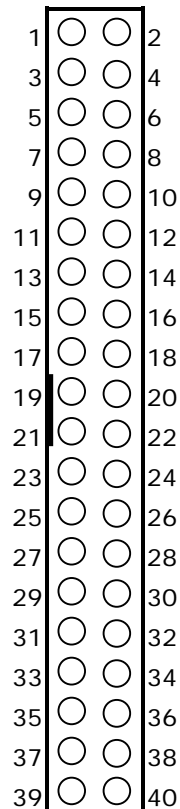

6.1.6.8. CN7: PCI/ISA Expansion Slot

The PC 661 provides an ISA/PCI slot for ISA and PCI device expansion.

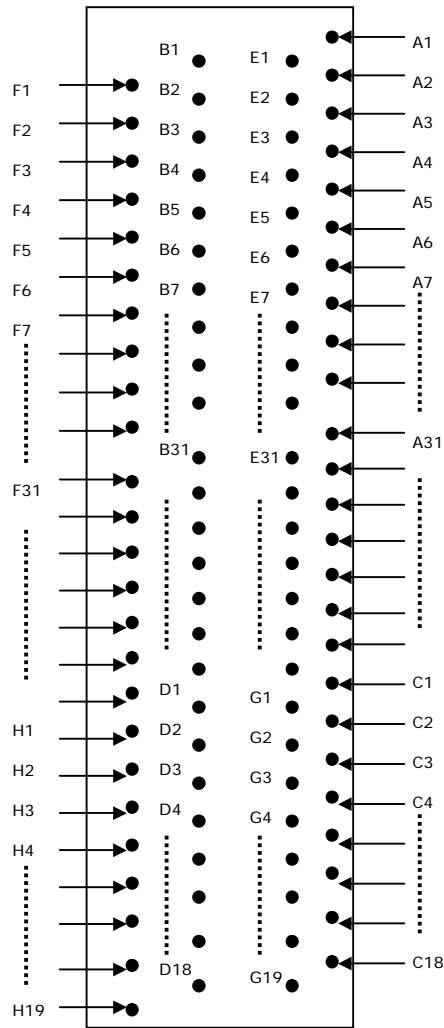

CN7: PCI/ISA Slot Side

## CN7: PCI/ISA Slot Connector Pin Assignment

Pin	Signal	Pin	Signal	Pin	Signal	Pin	Signal
F1	GND	B1	GND	E1	GND	A1	IOCHK
F2	GND	B2	ISARST	E2	GND	A2	SD7
F3	INTB	B3	VCC	E3	INTC	A3	SD6
F4	INTA	B4	IRQ9	E4	INTD	A4	SD5
F5	VCC	B5	-5V	E5	VCC	A5	SD4
F6	KEY	B6	DRQ2	E6	KEY	A6	SD3
F7	VCC	B7	-12V	E7	VCC	A7	SD2
F8	PCICLK1	B8	OWS	E8	PCIRST	A8	SD1
F9	GND	B9	+12V	E9	GNT0	A9	SD0
F10	GNT3	B10	GND	E10	REQ0	A10	IORDY
F11	GND	B11	SMEMW	E11	GND	A11	AEN
F12	REQ3	B12	SMEMR	E12	PCILKE2	A12	SA19
F13	AD31	B13	IOW	E13	GND	A13	SA18
F14	AD29	B14	IOR	E14	AD30	A14	SA17
F15	NC	B15	DACK3	E15	NC	A15	SA16
F16	KEY	B16	DRQ3	E16	KEY	A16	SA15
F17	NC	B17	DACK1	E17	NC	A17	SA14
F18	AD27	B18	DRQ1	E18	AD28	A18	SA13
F19	AD25	B19	REF	E19	AD26	A19	SA12
F20	CBE3	B20	ATCLK	E20	AD24	A20	SA11
F21	AD23	B21	IRQ7	E21	AD22	A21	SA10
F22	AD21	B22	IRQ6	E22	AD20	A22	SA9
F23	AD19	B23	IRQ5	E23	AD18	A23	SA8
F24	NC	B24	IRQ4	E24	NC	A24	SA7
F25	KEY	B25	IRQ3	E25	KEY	A25	SA6
F26	NC	B26	DACK2	E26	NC	A26	SA5
F27	AD17	B27	TC	E27	AD16	A27	SA4
F28	IRDY	B28	ALE	E28	FRAME	A28	SA3

To continue...

Pin	Signal	Pin	Signal	Pin	Signal	Pin	Signal
F29	DEVSEL	B29	VCC	E29	CBE2	A29	SA2
F30	LOCK	B30	OSC	E30	TRDY	A30	SA1
F31	PERR	B31	GND	E31	STOP	A31	SA0
H1	SERR	D1	MEMCS16	G1	NC	C1	SBHE
H2	AD15	D2	IOCS16	G2	NC	C2	LA23
H3	AD14	D3	IRQ10	G3	CBE1	C3	LA22
H4	AD12	D4	IRQ11	G4	PAR	C4	LA21
H5	GND	D5	IRQ12	G5	GND	C5	LA20
H6	KEY	D6	IRQ15	G6	KEY	C6	LA19
H7	GND	D7	IRQ14	G7	GND	C7	LA18
H8	AD10	D8	DACK0	G8	AD13	C8	LA17
H9	AD8	D9	DRQ0	G9	AD11	C9	MEMR
H10	AD7	D10	DACK5	G10	AD9	C10	MEMW
H11	AD5	D11	DRQ5	G11	CBE0	C11	SD8
H12	AD3	D12	DACK6	G12	AD6	C12	SD9
H13	AD1	D13	DRQ6	G13	AD4	C13	SD10
H14	AD0	D14	DACK7	G14	AD2	C14	SD11
H15	KEY	D15	DRQ7	G15	KEY	C15	SD12
H16	VCC	D16	VCC	G16	VCC	C16	SD13
H17	VCC	D17	MASTER	G17	VCC	C17	SD14
H18	GND	D18	GND	G18	GND	C18	SD15
H19	GND			G19	GND		

6.1.6.9. CN8/CN9: Flat Panel Connector

CN8 is a 50-pin flat panel connector and CN9 is a LCD backlight connector. Their pin assignments are listed below.

CN8: Flat Panel Connector

Pin	Signal	Pin	Signal
1	VCC	2	VCC
3	GND	4	GND
5	VCC3	6	VCC3
7	NC	8	NC
9	B0	10	B1
11	B2	12	B3
13	B4	14	B5
15	B6	16	B7
17	G0	18	G1
19	G2	20	G3
21	G4	22	G5
23	G6	24	G7
25	R0	26	R1
27	R2	28	R3
29	R4	30	R5
31	R6	32	R7
33	GND	34	GND
35	VGCLK	36	VBVSYNC
37	VBBLANK#	38	VBHSYNC
39	GND	40	GND
41	NC	42	NC
43	GND	44	SSYNC
45	GND	46	GND
47	ENVB2	48	PCIRST#
49	ENEXTPLK	50	INT#A

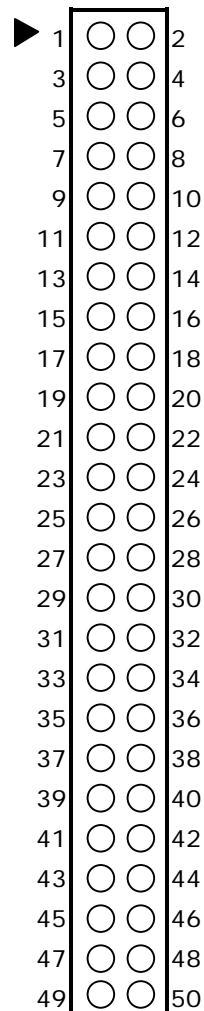

6.1.6.10. CN9: LCD Backlight Connector

Pin #	Signal
1	GND
2	GND
3	ENABKL
4	+12V

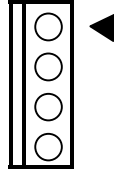

6.1.6.11. IDE1/IDE2: IDE Connector

IDE2 is a 44-pin secondary IDE connector and IDE1 is a 40-pin primary IDE connector. Their corresponding pin assignments are listed below;

IDE1: Primary IDE Connector

Pin #	Signal	Pin #	Signal
1	RST	2	GND
3	D7	4	D8
5	D6	6	D9
7	D5	8	D10
9	D4	10	D11
11	D3	12	D12
13	D2	14	D13
15	D1	16	D14
17	D0	18	D15
19	GND	20	NC
21	DRQ#	22	GND
23	IOW#	24	GND
25	IOR#	26	GND
27	CHRDY	28	NC
29	DACK#	30	GND
31	IRQ15	32	NC
33	A1	34	NC
35	A0	36	A2
37	CS0#	38	CS1#
39	LED indicator	40	GND

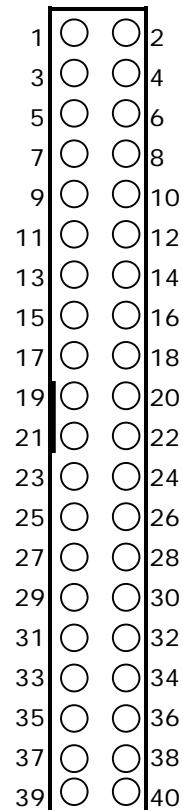

IDE2: Secondary IDE

Pin #	Signal	Pin #	Signal
1	RST	2	GND
3	DATA7	4	DATA8
5	DATA6	6	DATA9
7	DATA5	8	DATA10
9	DATA4	10	DATA11
11	DATA3	12	DATA12
13	DATA2	14	DATA13
15	DATA1	16	DATA14
17	DATA0	18	DATA15
19	GND	20	NC
21	DRQ#	22	GND
23	IOW#	24	GND
25	IOR#	26	GND
27	CHRDY	28	NC
29	ACK#	30	GND
31	IRQ14	32	N/C
33	A1	34	N/C
35	A0	36	A2
37	CS0#	38	CS1#
39	LED indicator	40	GND
41	Vcc5	42	Vcc5
43	GND	44	NC

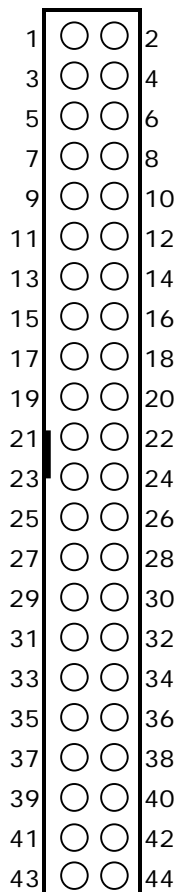



## **7. AWARD BIOS SETUP**

The chapter describes how to set up BIOS configuration.

### 7.1.1. Main Menu

The on-line description of the highlighted setup function is displayed at the bottom of the screen.

Press <F1> to pop up a small help window that describes the appropriate keys to use and the possible selections for the highlighted item. To exit the Help Window, press <ESC>.

## 7.2. AWARD BIOS Setup

### 7.2.1. AWARD BIOS Setup Main Menu

Power on the computer and press <DEL> immediately to run the AWARD BIOS setup. The setup main menu will appear on the screen;

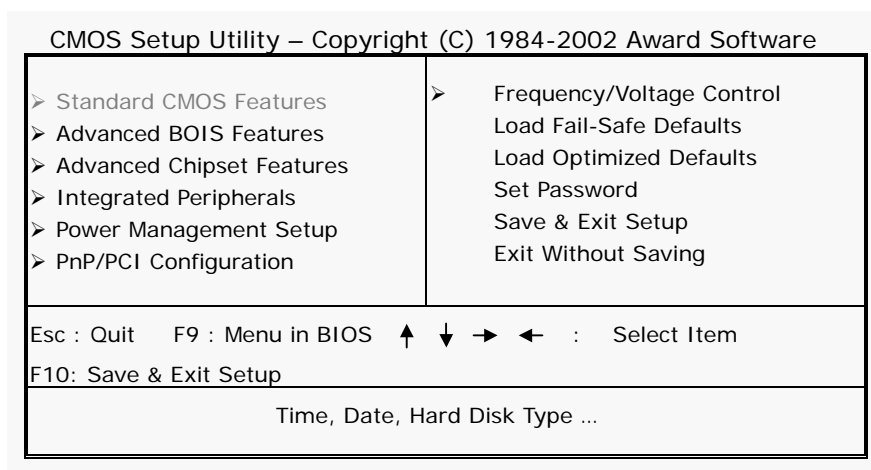

Use the arrow keys to move among the items and press <Enter> to enter the sub-menu.

- ◆ **STANDARD CMOS SETUP:** This setup page includes all the items in standard compatible BIOS.
- ◆ **ADVANCED BIOS FEATURES:** This setup page includes all the items of Award special enhanced features.
- ◆ **ADVANCED CHIPSET FEATURES:** This setup page includes all the items of chipset special features.
- ◆ **INTEGRATED PERIPHERALS:** This setup page includes all onboard peripherals.
- ◆ **POWER MANAGEMENT SETUP:** This setup page includes all the items of Green function features.
- ◆ **PNP/PCI CONFIGURATION:** This setup page includes all the configurations of PCI & PnP ISA resources.
- ◆ **PC HEALTH STATUS:** This setup page auto detects the temperature, voltage and fan speed.
- ◆ **FREQUENCY/VOLTAGE CONTROL:** This setup page includes the CPU/SDRAM/PCI frequency setting
- ◆ **LOAD FAIL-SAFE DEFAULTS:** BIOS Defaults indicates the most appropriate value of the system parameters that the system would be in safe configuration.
- ◆ **LOAD OPTIMIZED DEFAULTS:** Setup Defaults indicates the value of the system parameters that the system would be in the best performance configuration.
- ◆ **SET PASSWORD:** Change, set, or disable password. It allows you to limit access to the system and Setup, or just to Setup.
- ◆ **SAVE & EXIT SETUP:** Save CMOS value settings to CMOS and exit setup.
- ◆ **EXIT WITHOUT SAVING:** Abandon all CMOS value changes and exit setup.

### 7.2.2. Standard CMOS Features

If the **STANDARD CMOS FEATURE** is selected from the main menu, the screen below will appear. This menu allows the users to configure the system components such as date, time, hard disk drive, floppy disk drive and display type. The system BIOS will automatically detect the memory size; therefore no setting is needed.

CMOS Setup Utility – Copyright (C) 1984-2002 Award Software  
Standard CMOS Features

Date (mm: dd: yy) Tue, Mar 6 2001	Item Help
Time (hh: mm: ss)	Menu Level ▶
▶ IDE Primary Master	Change the day, month, year and century
▶ IDE Primary Slave	
▶ IDE Secondary Master	
▶ IDE Secondary Slave	
Drive A (1.44M, 3.5 in.)	
Drive B (None)	
Video (EGA/VGA)	
LCD Panel ID Select (Type 0)	
Full Screen Function (Disable)	
Halt On (All, But Keyboard)	
Base Memory 640K	
Extended Memory 64448K	
Total Memory 65536K	

↑ ↓ → ←: Move Enter : Select +/-/PU/PD: Value F10: Save  
ESC: Exit F1: General Help F5: Previous Values F6: Fail-Safe Defaults  
F7: Optimized Defaults

\*DISPLAY PAC-PPC with TV out function without LCD Panel ID Select & Full Screen Function Selections.

---

**◆ DATE**

The date format is <day>, <month> <date> <year>.

day	The day, from Sun to Sat, determined by the BIOS and is display-only
month	The month, Jan. through Dec.
date	The date, from 1 to 31 (or the maximum allowed in the month)
year	The year, from 1994 through 2079

**◆ TIME**

The times format in <hour> <minute> <second>. The time is calculated base on the 24-hour military-time clock. For example, 1 p.m. is 13:00:00.

**◆ PRIMARY HDDs / SECONDARY HDDs**

The category identifies the types of hard disk from drive C to F that has been installed in the computer. There are two types: auto type, and user definable type. User type is user-definable; Auto type which will automatically detect HDD type.

Note that the specifications of your drive must match with the drive table. The hard disk will not work properly if you enter improper information for this category.

If you select User Type, related information will be asked to enter to the following items. Enter the information directly from the keyboard and press <Enter>. Such information should be provided in the documentation form your hard disk vendor or the system manufacturer.

Cylinder	Number of cylinders
Head	number of heads
Precomp	write precomp
Landing Zone	Landing zone
Sectors	number of sectors

If a hard disk has not been installed select *NONE* and press <Enter>.

◆ **DRIVE A TYPE / DRIVE B TYPE**

The category identifies the types of floppy disk drive A or drive B that has been installed in the computer.

None	No floppy drive installed
360K, 5.25"	5.25 inch PC-type standard drive; 360K byte
1.2M, 5.25"	5.25 inch AT-type high-density drive; 1.2M byte (3.5 inch when 3 Mode is Enabled).
720K, 3.5"	3.5 inch double-sided drive; 720K byte
1.44M, 3.5"	3.5 inch double-sided drive; 1.44M byte
2.88M, 3.5"	3.5 inch double-sided drive; 2.88M byte

◆ **VIDEO**

The category selects the default video device

Options: EGA/VGA/CGA40/CGA80/Mono

◆ **LCD PANEL ID SELECT**

The category lists the ID select of different size LCD.

◆ **FULL SCREEN FUNCTION**

Enable/Disable the full screen function

◆ **HALT ON**

The category determines whether the computer will stop if an error is detected during power up.

All Errors	Whenever the BIOS detects a non-fatal error the system will be stopped and you will be prompted
NO Errors	The system boot will not stop for any error that may be detected
All, But Keyboard	The system boot will not stop for a keyboard error; it will stop for all other errors
All, But Diskette	The system boot will not stop for a disk error; it will stop for all other errors
All, But Disk/Key	The system boot will not stop for a keyboard or disk error; it will stop for all other errors

### 7.2.3. Advanced BIOS Features

If the **ADVANCED BIOS FEATURES** option is selected from the main menu, the screen below will appear. The following sample screen consists of the default values for **PC661**.

CMOS Setup Utility – Copyright (C) 1984-2002 Award Software  
Advanced BIOS Features

		Item Help
Virus Warning	(Disabled)	
CPU Internal Cache	(Enabled)	Menu Level
External Cache	(Enabled)	
CPU L2 Cache ECC Checking	(Enabled)	Allow you to choose the
Quick Power On Self Test	(Disabled)	VIRUS warning
First Boot Device	(Disabled)	features for IDE Hard
Second Boot Device	(HDD-0)	Disk boot sector
Third Boot Device	(LS120)	protection. If this
Boot Other Device	(Enabled)	function is enabled and
Swap Floppy Drive	(Disabled)	someone attempt to
Boot up Floppy Seek	(Enabled)	write data into this
Boot up NumLock Status	(ON)	area, BIOS will show a
Gate A20 Option	(Fast)	warning message on
Typematic Rate Setting	(Disabled)	the screen and alarm
x Typematic Rate (Chars/Sec)	6	beep
x Typematic Rate Delay (Msec)	250	
Security Option	(Setup)	
OS Select For DRAM > 64MB	(Non-OS2)	

↑ ↓ → ←: Move    Enter : Select    +/-/PU/PD: Value    F10: Save  
 ESC: Exit    F1: General Help    F5: Previous Values    F6: Fail-Safe Defaults  
 F7: Optimized Defaults

### 7.2.4. Advanced Chipset Features

If the **ADVANCED CHIPSET FEATURES** option is selected from the main menu, the screen below will appear. The following sample screen consists of the default values for **PC661**

CMOS Setup Utility – Copyright (C) 1984-2002 Award Software  
Advanced Chipset Features

	Item Help
➤ Advanced DRAM Control 1 (Press Enter)	
➤ Advanced DRAM Control 2 (Press Enter)	Menu Level ▶
System BIOS Cacheable (Enabled)	
Video RAM Cacheable (Enabled)	
Memory Hole at 15M-16M (Disabled)	
AGP Aperture Size (64MB)	
Graphic Window WR Combin (Enabled)	
Concurrent function (MEM) (Enabled)	
Concurrent function (PCI) (Enabled)	
CPU Pipeline Control (Enabled)	
PCI Delay Transaction (Enabled)	
Memory Parity Check (Enabled)	

↑ ↓ → ←: Move    Enter : Select    +/-/PU/PD: Value    F10: Save  
 ESC: Exit    F1: General Help    F5: Previous Values    F6: Fail-Safe Defaults  
 F7: Optimized Defaults

### 7.2.5. Integrated Peripherals

If the **INTEGRATED PERIPHERALS** option is selected from the main menu, the screen below will appear. The following sample screen consists of the default values for **PC661**.

CMOS Setup Utility – Copyright (C) 1984-2002 Award Software  
Advanced BIOS Features

	Item Help
➤ SIS 630 OnChip IDE Device (Press Enter)	
➤ SIS 630 OnChip PCI Device (Press Enter)	Menu Level ▶
USB Controller (Enabled)	
USB Keyboard Support (Disabled)	
IDE HDD Block Mode (Enabled)	
Onboard FDC Controller (Enabled)	
Onboard Serial Port 1 (3F8/IRQ4)	
Onboard Serial Port 2 (2F8/IRQ3)	
IR Transmission Delay (Enabled)	
UART Mode Select (Normal)	
RxD , TxD Active (Hi, Lo)	
UR2 Duplex Mode (Half)	
Use IR Pins (IR-Rx2Tx2)	
Onboard Serial Port 3 (3f8)	
Serial Port 3 Use IRQ (IRQ 10)	
Onboard Serial Port 4 (2E8)	
Serial Port 4 Use IRQ (IRQ 11)	
Onboard Parallel Port (378/IRQ7)	
Parallel Port Mode (SPP)	
EPP Mode Select (EPP1.7)	
ECP Mode Use DMA (3)	
Init Display First (PCI Slot)	
Fast Write Capability (Enabled)	
AGP 4X Capability (Enabled)	
AGP Auto Calibration (Enabled)	
System Share Memory Size (8 MB)	
Extend Graphic Memory (0 MB)	
SiS 301 Display type (Auto)	

↑ ↓ → ←: Move Enter : Select +/-/PU/PD: Value F10: Save  
ESC: Exit F1: General Help F5: Previous Values F6: Fail-Safe Defaults  
F7: Optimized Defaults

\*SiS 301 board for TV-out function is an optional device.

### 7.2.6. Power Management Setup

If the **POWER MANAGEMENT SETUP** option is selected from the main menu, the screen below will appear. The following sample screen consists of the default values for **PC661**.

CMOS Setup Utility – Copyright (C) 1984-2002 Award Software  
Power Management Setup

ACPI function	(Enabled)	Item Help
Video OFF Option	(Susp, Stby - Off)	Menu Level ▶
Video Off Method	(V/H, SYNC+B) ank)	
Switch Function	(Break/Wake)	
Modem Use IRQ	(3)	
Hot Key Function As	(Power Off)	
HDD Off After	(Disable)	
Power Button Override	(Instant Off)	
➤ PM Wake Up Event	(Press Enter)	

↑ ↓ → ←: Move Enter : Select +/-/PU/PD: Value F10: Save  
ESC: Exit F1: General Help F5: Previous Values F6: Fail-Safe Defaults  
F7: Optimized Defaults

### 7.2.7. PnP/PCI Configuration

If the **PNP/PCI CONFIGURATION** option is selected from the main menu, the screen below will appear. The following sample screen consists of the default values for **PC661**.

CMOS Setup Utility – Copyright (C) 1984-2002 Award Software  
PnP PCI Configuration

		Item Help
Reset Configuration Data	(Disabled)	Menu Level ▶
Resources Controlled By x IRQ Resources	(Auto(ESCD)) Press Enter	Default is Disabled.
PCI/VGA Palette Snoop	(Disabled)	Select Enabled to rest Extended System Configuration Data ESCD) when you exit Setup if you have installed a new add-on and the system reconfiguration has caused such a serious conflict that the OS cannot boot

↑ ↓ → ←: Move    Enter : Select    +/-/PU/PD: Value    F10: Save  
ESC: Exit    F1: General Help    F5: Previous Values    F6: Fail-Safe Defaults  
F7: Optimized Defaults

### 7.2.8. Frequency Voltage Control

This setup page is for the CPU, SDRAM and PCI frequency setting.

CMOS Setup Utility – Copyright (C) 1984-2002 Award Software  
Frequency Voltage Control

		Item Help
Auto Detect DIMM/PCI Clk	(Enabled)	
Spread Spectrum	(Disabled)	Menu Level ▶
CPU Host/SDRAM/PCI Clock	(Default)	
CPU Clock Ratio Jumpless	(By H/W)	

↑ ↓ → ←: Move    Enter : Select    +/-/PU/PD: Value    F10: Save  
ESC: Exit    F1: General Help    F5: Previous Values    F6: Fail-Safe Defaults  
F7: Optimized Defaults

### 7.2.9. Load Fail-Safe Defaults

The default values of the **LOAD FAIL-SAFE DEFAULTS** indicates the most appropriate value of the system parameters that the system would be in safe configuration.

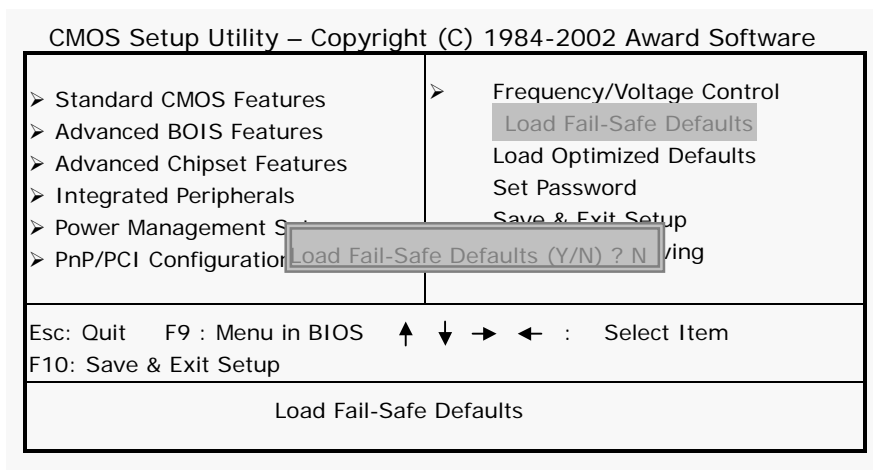

### 7.2.10. Load Optimized Defaults

The default values of the **LOAD OPTIMIZED DEFAULTS** indicates the most appropriate value of the system parameters that the system would be in best performance configuration.

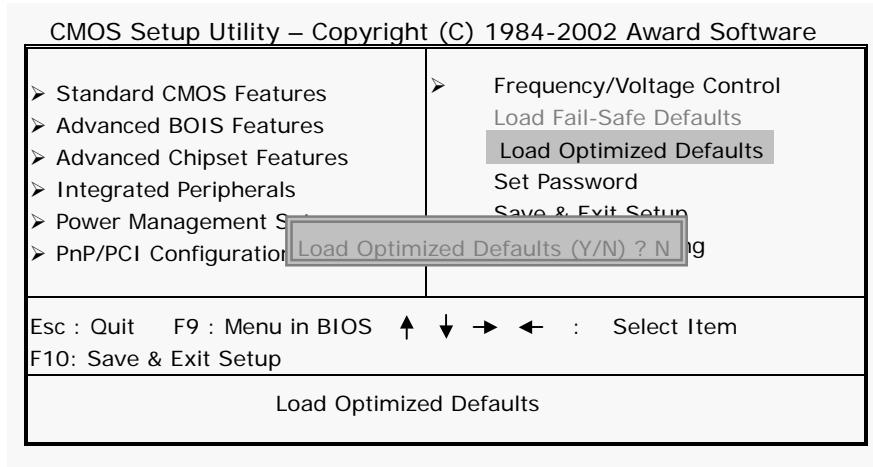

### 7.2.11. User Password

The **USER PASSWORD** is used to set the password. To change the password, select this option from the main menu and press <Enter>.

If the CMOS does not work properly or the **USER PASSWORD** option is selected for the first time, then a default password is stored in the ROM. The following message will appear on the screen;

**Enter Password**

Press <Enter>.

If the CMOS is working properly or the **USER PASSWORD** option is selected to change the default password, then the current password (the ROM password or the use-defined password) stored in the ROM needs to be entered first. The following message will appear on the screen;

**Confirm Password**

Enter the current password and press <Enter>.

After pressing <Enter>, then the new password (8 characters at most) can be entered now. The new password will be stored in the CMOS.

Please note that to enable this option, either **Setup** or **System** is to be selected from the **ADVANCED BIOS FEATRUES** first.

### 7.2.12. Save and Exit Setup

If the **SAVE & EXIT SETUP** option is selected, the values entered the setup utilities will be saved in the chipset's CMOS memory. When the system is turned on every time, the CPU will check the CMOS to compare the CMOS data to see whether it matches the system. These data are very important for the system operation.

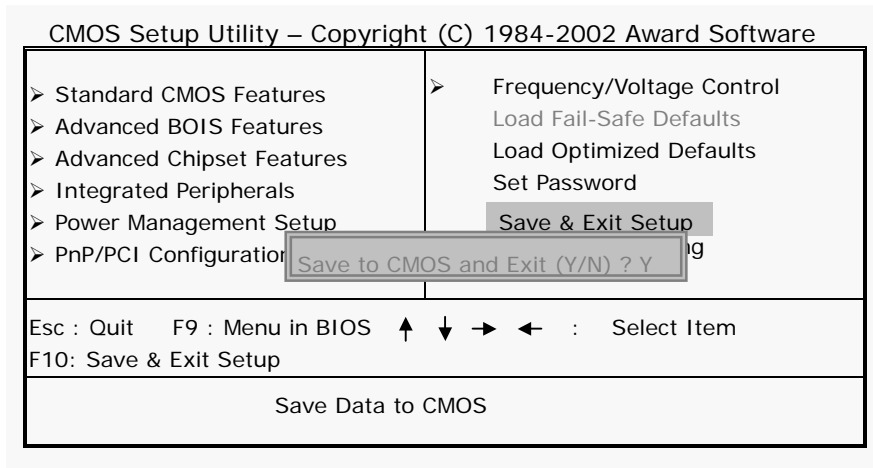

### 7.2.13. Exit Without Saving

If the **EXIT WITHOUT SAVING** option is selected and <ENTER> is pressed, you will exit the Setup program without saving any new values. The CMOS will still keep the old values.

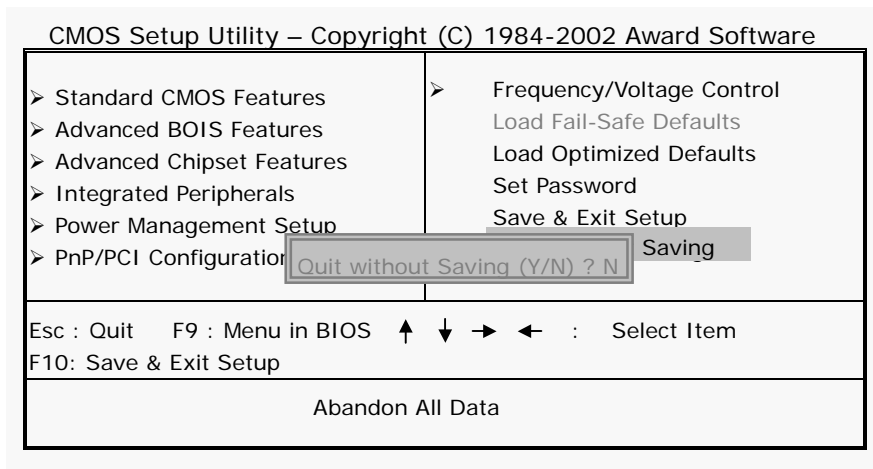

## **8. TOUCH SCREEN**

For keyboard less operation, the DISPLAY PAC-PPC provides an optional touch screen. The DISPLAY PAC-PPC system can use either ELO resistive type touch screen or ELO Intelli touch. This chapter details the procedures to install the software drivers under DOS and Windows operation.

## **8.1. Elo Touch screen Driver Installation**

The Elo resistive touch and Intelli touch will use the same drivers and utilities which are stored in the Driver CD diskette.

### **8.1.1. System Requirements**

The DOS drivers will run on any system with DOS 2.0 or later version. The Windows drivers will run on any system with Windows 3.1 or later versions. The DOS demonstration program requires a VGA color display. The touch screen calibration program for DOS supports standard and VESA-compatible display modes. Otherwise, all software is video independent. An Elo touch screen must be installed on the display and connected to a serial or bus controller.

### **8.1.2. About Elo Software**

#### **Software Included**

The accompanying DOS and Windows Driver Disk contains the following Elo driver software:

**EloDEV** Touch screen driver program for DOS :

This program makes all Elo touch screen controllers, including serial RS-232, PC-Bus, and Micro Channel versions look the same to other driver and application programs.

**MonitorMouse for DOS** Mouse emulation driver for DOS : This program combines touch input from EloDEV and mouse input from your mouse driver into a single MOUSE.COM-compatible application interface.

**MonitorMouse for Windows** Mouse emulation driver for Microsoft Windows : This program allows all Windows programs to be used with a touch screen. Your mouse may be used in conjunction with the touch screen. DOS mouse-driven programs run from Windows may also use the touch screen.

**TouchBack** Keystroke emulation driver for DOS : Applications must be specially written for use with TouchBack. Your application documentation should specify if TouchBack is required.

The DOS and Windows Driver Disk also contains the following software:

**EloDEMO** A VGA-graphics program for DOS which demonstrates the capabilities of the touch screen hardware and many techniques for touch screen software.

**Utility and Diagnostic Programs** An assortment of programs are included to calibrate the touch screen and verify the operation of serial ports, touch screen controllers, and driver programs.

### **8.1.3. Installation**

This section details the installation procedures for the software on the DOS and Windows Driver Disk. Four steps are required:

- Step 1 Configuring the touch screen controller
- Step 2 Installing the controller
- Step 3 Running the INSTALL program
- Step 4 Calibrating the touch screen

#### **STEP 1 - CONFIGURING THE TOUCH SCREEN CONTROLLER**

THE MANUFACTURER ships most touch screen controllers preconfigured for use with Elo software.

#### **STEP 2 - INSTALLING THE CONTROLLER**

If you need help when installing the touch screen controller or making the connections, please contact the Manufacturer's Customer Service department.

#### **STEP 3 - RUNNING THE INSTALL PROGRAM**

The DOS and Windows Driver Disk contains an installation program which will automatically transfer all necessary files to the hard disk.

If you intend to install the Windows drivers, make sure that the Windows has been installed and operating properly before proceeding. *You must have a DOS mouse driver (MOUSE.COM) installed for your mouse if you wish to continue using your mouse along with the touch screen in DOS or Windows.*

If you only want to change the configuration of your touch screen controller, *see Changing Your Hardware Configuration with SETUP.*

Respond to the on-screen prompts and instructions. You will be asked to specify the model and configuration of your

controller, then select between **DOS Express Installation**, **Windows Express Installation**, or **Selective Installation**. The touch screen controller of the **DISPLAY PAC-PPC I** is serial type. The model number is **E271-2210 AccuTouch**. Baud rate of the controller is **"9600"**. The **DISPLAY PAC-PPC I** uses onboard **COM3** to drive this controller, **IRQ** is selected by **BIOS setting**. **IRQ10** is the factory default setting for **COM3**. The software to be installed and disk space requirements will be displayed for each installation option. You may specify the drive and directory for the files you choose to install, or use the default (C:\TOUCH).

The **INSTALL** program will modify your **AUTOEXEC.BAT** file, (and **SYSTEM.INI** file for Windows installations). Copies of the original files will be saved as **AUTOEXEC.OLD** and **SYSTEM.OLD**.

#### 8.1.4. Installing MonitorMouse for Windows system

1. Turn on your computer.
2. To install the software, insert the Driver CD. The path as x:\Drivers\Elo Touch\ (X = your CD device number)
3. Open one folder which same as your operating system.
4. Double click the only one file in this folder and Unzip to a folder such as "c:\EloWin9X".
5. Chang to "c:\EloWin9X" double click setup.exe.
6. Following the instructions on the screen.
7. The Touch screen Setup Wizard will appear. You will need to specify the type of touch screen controller you are using and how it is connected.  
Control type: serial  
SmartSet: 2xx0  
COM port: COM3
8. Complete the Setup program.
9. Restart your system.
10. Click the Start button, then click Settings, and then click *Control Panel*.
11. Double-click *Elo Touch screen* to run the Touch screen Control panel.
12. Click the *Calibrate* button and touch each of the three targets as they appear on the screen. Click *Yes* when the cursor lines up correctly with your finger. Click *OK* to close the Touch screen Control panel.

#### NOTES

- ◆ Full-screen DOS mode is not supported. However, Windowed DOS mode is fully supported. A touch to a full-screen DOS session will cause your system to immediately return to your Windows desktop. A mouse can be used to access programs run in full-screen DOS mode.

- ◆ Windows 95 may lock up during startup if the resource settings in the Setup dialog of the *Touch screen Control Panel* do not match the actual controller configuration. Use *Safe Mode* to start Windows 95 and change the resource settings to match the controller configuration, then restart Windows 95.
- ◆ The touch screen driver may cause Windows 95 to lock up during Shutdown if the touch screen is activated after Shutdown is initiated.

### **Removing the Mouse Pointer**

If you wish to eliminate the mouse pointer, you may replace it with the null cursor file, NULL.CUR, supplied with MonitorMouse for Windows 95. Follow the following steps to install the null cursor file;

1. Open the *Control Panel* and select *Mouse*.
2. Select the *Pointers* tab.
3. Highlight the *Normal Select* cursor then select *Browse*.
4. Type " null.cur" in the space provided and select *Open*.
5. Select *OK* to select the option.
6. Exit from the *Mouse Control Panel*. You should notice that the arrow cursor has disappeared. Note that all other cursors will still function as before.

---

### MonitorMouse for Windows 95 Uninstall Procedure

1. Close the Windows *Control Panel* if it is open.
2. Delete the following files from your \Windows\System folder: MONMOUSE.VXD, MONMOUSE.HLP, and MONMOUSE.CPL.
3. Start the REGEDIT.EXE program to edit the registry (click the *Start* button, click *Run*, type "regedit" and press <Enter>). Delete the following keys from the registry:

HKEY\_CURRENT\_USER\Control  
Panel\desktop\DoubleClickHeight

HKEY\_CURRENT\_USER\Control  
Panel\desktop\DoubleClickWidth

Delete the following registry key folders and their contents:

HKEY\_LOCAL\_MACHINE\System\CurrentControlSet\Services\VxD\  
MonMouse

HKEY\_LOCAL\_MACHINE\SOFTWARE\Elo  
TouchSystems

4. Use Notepad to delete the following line from the [386Enh] section of the SYSTEM.INI file:  
device=monmouse.vxd
5. Delete the directory C:\Elo to remove the touch screen diagnostic programs and sample Z-axis and calibration programs.

Restart Windows.

### **8.1.5. Getting More Information**

For more information on installing the Elo software driver to the DISPLAY PAC-PPCsystem or to download Elo touch screen drivers, please visit Elo Touchsystem website

<http://www.elotouch.com>

Click the *Support* button and follow the instruction on the screen to download Elo software or documentation.

If after consulting the documentation, you still need help with the setup of the Elo touch software to the system, you can click the *Technical* button to locate Elo global service points for help.

---

## Appendix

### A: Programming the Watchdog Timer

The DISPLAY PAC-PPC features a watchdog timer that can generate a system reset if the CPU processing comes to a halt. This feature ensures the system dependability during unattended operation. The watchdog timer is programmable. In order to program the watchdog timer, a program writing I/O port address 443 (hex) needs to be written first. The output data is a value of time interval. The value ranges from 01(hex) to 3F(hex), and the related time interval ranges from 0 to 63 seconds.

Data	Time Interval
00	0 sec.
01	2 sec.
02	4 sec.
03	6 sec.
⋮	⋮
0F	30 sec.

After entering the data, the program has to refresh the watchdog timer by rewriting the I/O port 443 (hex) and setting it at the same time. To disable the watchdog timer, the program should read I/O port 143 (hex).

The following is a sample program illustrating the way to program the watchdog timer in BASIC.

```
10  REM Watchdog timer example program
20  OUT &H443, data REM enable the watchdog timer
30  GOSUB 1000 REM Your application task #1
40  OUT &H443, data REM Reset the timer
50  GOSUB 1000 REM Your application task #1
60  OUT &H443, data REM Reset the timer
70  X=INP (&H143) REM Disable the watchdog timer
80  End

      |
1000 REM Subroutine #1, your application task
      |
1090 Return
      |
2000 REM Subroutine #2, your application task
      |
2090 Return
```

## B: DiskOnChip® Installation

The DISPLAY PAC-PPC is equipped with an internal flash disk which can emulate a floppy disk drive by adapting DiskOnChip® memory chips from 2MB to 144MB capacity, and the flash disk is fully compatible with floppy disk format of MS-DOS system.

To install a DiskOnChip® memory to the provided socket, follow the instructions below;

1. Make sure the computer is turned off
2. Insert the DiskOnChip® memory device into the onboard socket. Make sure that pin 1 of the DiskOnChip® is aligned with the pin 1 of the socket.
3. Power up the computer
4. During the power up, the DiskOnChip® drivers will be automatically loaded into the system memory.
5. At this time, the DiskOnChip® can be accessed as any disk drive.
6. If it is the only disk in the system, it will appear as the first drive, drive C: .
7. If there are more drives already attached to the system, then by default, the DiskOnChip® will appear as the last drive unless specially programmed.
8. If the DiskOnChip® is to be bootable, then follow the steps below
  - a. Use DOS command to copy the operating files into the DiskOnChip®
  - b. The DiskOnChip® is to be configured as the first drive, drive C: in the system. Use the DUPDATE utility.  
DUPDATE D /S: DOC104.EXB /FIRST (set as c:)  
DUPDATE C /S: DOC104.EXB (set as d:)

For more information and for the latest software utility and utilities manual on the DiskOnChip®, visit M-System website at [www.m-sys.com](http://www.m-sys.com) .

## C: RS-485 Programming

The RS-485 is software programmable. In order to program the RS-485, a program writing I/O port address 204 (hex) needs to be written first. The output data is a value of RS-485 TX/RX status. The data function definition is listed below:

RS-485

SD0	SD1	TX	RX
0	0	Disable	Enable
0	1	Enable	Enable
1	0	Disable	Disable
1	1	Enable	Enable

Note: data D7~D2 have no bits concern.

**D: System I/O Ports**

<b>Address range (Hex)</b>	<b>Device</b>
000-01F	DMA controller
020-021	Interrupt controller 1, master
022-023	Chipset address
040-05F	8254 timer
060-06F	8024 keyboard controller
070-07F	Real time clock, non-maskable interrupt mask (NMI)
080-09F	DMA page register
0A0-0BF	Interrupt controller 2
0C0-0DF	DMA controller
0F0	Clear math co-processor
0F1	Reset math co-processor
0F8-0FF	Math co-processor
1F0-1F8	Fixed disk
200	Game I/O (not used)
443	Watchdog timer
143	Watchdog timer
206	DIO port
2E8	Serial port #4
2F8-2FF	Serial port #2
300-31F	Prototype card (not used)
360-36F	Reserved
378-37F	Parallel printer port 1 (LPT1)
380-38F	SDLC, bisynchronous 2 (not used)
3A0-3AF	Bisynchronous 1 (not used)
3B0-3BF	Monochrome display and printer adapter (LPT1) (not used)
3C0-3CF	Reserved
3D0-3DF	Color/graphics monitor adapter
3E8	Serial port #3
3F0-3F7	Diskette controller
3F8-3FF	Serial port #1

\* MPU-401 select from 300~330H (2 bytes)

## E: First MB Memory Map

Address range (Hex)	Device
F000h-FFFFh	System ROM
C800h-EFFFh	Unused
C000h-C7FFh	Expansion ROM
B800h-BFFFh	CGA/EGA/VGA text
B000h-B7FFh	Unused
A000h-AFFFh	EGA/VGA graphics
0000h-9FFFh	Base memory
D000-DFFFh	DiskOnChip®

## F.TV-out Interface (Optional SiS301 Board)

The TV-out interface supported by optional device with **SiS301** Chipset contains two types of connectors, one S-terminal connector and the other RCA jack. The TV-out interface is used when the TV or NTSC monitor is used as the display monitor. Please note that either the TV or the LCD can be used as the display at a given time.

Due to chipset limitation, when the TV monitor is used as the display, the graphic mode is viewable while the text is hardly legible.

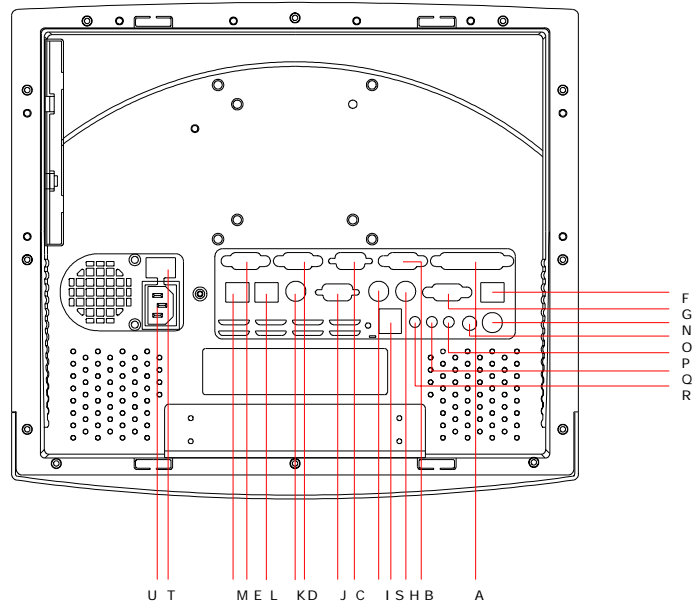

- N. TV-out S-terminal (Optional SiS301)
- O. TV-out RCA Jack (Optional SiS301)

## To use the TV-out, the TV-out function in the BIOS setup

CMOS Setup Utility – Copyright (C) 1984-2002 Award Software  
Standard CMOS Features

Date (mm: dd: yy) Tue, Mar 6 2001	Item Help
Time (hh: mm: ss)	Menu Level ▶
➤ IDE Primary Master	Change the day, month, year and century
➤ IDE Primary Slave	
➤ IDE Secondary Master	
➤ IDE Secondary Slave	
Drive A (1.44M, 3.5 in.)	
Drive B (None)	
Video (EGA/VGA)	
LCD Panel ID Select (Type 0)	
Full Screen Function (Disable)	
Halt On (All, But Keyboard)	
Base Memory 640K	
Extended Memory 64448K	
Total Memory 65536K	

↑ ↓ → ←: Move Enter : Select +/-/PU/PD: Value F10: Save  
ESC: Exit F1: General Help F5: Previous Values F6: Fail-Safe Defaults  
F7: Optimized Defaults

\*DISPLAY PAC-PPC with TV out function without LCD Panel ID Select & Full Screen Function Selections.

In **INTEGRATED PERIPHERALS** option is selected from the main menu, the SiS 301 Display type of the default values is (Auto) for auto detect NTSC or PAL mode.

CMOS Setup Utility – Copyright (C) 1984-2002 Award Software

Advanced BIOS Features

	Item Help
➤ SIS 630 OnChip IDE Device (Press Enter)	
➤ SIS 630 OnChip PCI Device (Press Enter)	Menu Level ►
USB Controller (Enabled)	
USB Keyboard Support (Disabled)	
IDE HDD Block Mode (Enabled)	
Onboard FDC Controller (Enabled)	
Onboard Serial Port 1 (3F8/IRQ4)	
Onboard Serial Port 2 (2F8/IRQ3)	
IR Transmission Delay (Enabled)	
UART Mode Select (Normal)	
RxD , TxD Active (Hi, Lo)	
UR2 Duplex Mode (Half)	
Use IR Pins (IR-Rx2Tx2)	
Onboard Serial Port 3 (3f8)	
Serial Port 3 Use IRQ (IRQ 10)	
Onboard Serial Port 4 (2E8)	
Serial Port 4 Use IRQ (IRQ 11)	
Onboard Parallel Port (378/IRQ7)	
Parallel Port Mode (SPP)	
EPP Mode Select (EPP1.7)	
ECP Mode Use DMA (3)	
Init Display First (PCI Slot)	
Fast Write Capability (Enabled)	
AGP 4X Capability (Enabled)	
AGP Auto Calibration (Enabled)	
System Share Memory Size (8 MB)	
Extend Graphic Memory (0 MB)	
SIS 301 Display type (Auto)	

↑ ↓ → ←: Move Enter : Select +/-/PU/PD: Value F10: Save  
 ESC: Exit F1: General Help F5: Previous Values F6: Fail-Safe Defaults  
 F7: Optimized Defaults

## G: Power Supply

The DISPLAY PAC-PPC can either accommodate an AC power supply or a DC power supply.

### G-1: AC POWER SUPPLY

The AC power supply used in the DISPLAY PAC-PPC system is a 100 watts forced air cooling power supply. It is a dual output switching power supply specially designed for the DISPLAY PAC-PPC system.

#### G-1-1: INPUT SPECIFICATIONS

- ✧ **Universal AC input voltage**  
The range of input voltage is from 85VAC to 264VAC.
- ✧ **Input frequency**  
The range of input frequency is between 47Hz to 63Hz.
- ✧ **Input current**  
The maximum input current is 3A at 115 VAC or 1.5A at 230 VAC.
- ✧ **Inrush current**  
The inrush current is less than 30A at 115 VAC or 60A at 230 VAC input, cold start at 25°C.

#### G-1-2: OUTPUT SPECIFICATIONS

- ✧ **Load range**

Output	Min. load	Rated load	Max. load	Accuracy range
+5V	2A	12A	16A	+5.05V to +5.15V
+12V	0A	1.0A	1.5A	+11.25V to +12.75V

  - a. At the factory, the +5V output is set between 5.00V to 5.10V at 60% rated load, and the +12V output is checked to be within the accuracy range.
  - b. The adjustable range for the +5V output is +/-5%.  
Note: +12V output voltage will track the adjustment.
- ✧ **Ripple and noise**  
The peak to peak ripple and noise for each output are less than 1% of output voltage at rated load which is measured by a 15MHz bandwidth limited oscilloscope and each output is connected with 0.47µF capacitor.

- ◇ **Line regulation**  
The line regulation is less than +/-1% at rated load with +/-10% change in input voltage.
- ◇ **Load regulation**  
The load regulation for +5V is less than +/-1%, for +12V less than +/-10%, which are measured by changing the output load from 20% to 100% of the rated load and the other output is kept at 60% rated load.

#### **G-1-3: GENERAL FEATURES**

- ◇ **Efficiency**  
The efficiency is higher than 70% while measuring at normal line and rated load.
- ◇ **Hold up time**  
The hold up time is longer than 16mS at 115VAC input and rated load
- ◇ **Protection**
  - a. **Over voltage protection:** The built-in crowbar circuit will shut down the outputs to avoid damaging the external circuits. This trip point of over voltage protection is around 6.4V to 7.4V. To recover from over voltage protection, cycle the AC line OFF and ON to make it restart.
  - b. **Short circuit protection:** The power supply will generate a hiccup mode to protect itself against short circuit or over load conditions and will return to normal after wrong conditions are removed.

#### **G-1-4: ENVIRONMENTAL SPECIFICATIONS**

- ◇ **Operating temperature**  
0°C to 50 °C
- ◇ **Storage temperature**  
-20°C to 70 °C
- ◇ **Humidity**  
10% to 90% non-condensing

**G-1-5: INTERNATIONAL STANDARD**

✧ **Safety standards**

Designed to meet the following standards  
UL 1950  
CSA 22.2 no. 234  
VDE EN 60 950

✧ **EMI standards**

Designed to meet the following limits  
FCC docket 20780 curve "B"  
EN55022 "B"

✧ **CE standards**

Designed to meet the following standards  
IEC-801-2 level 3 8KV air discharge  
IEC-801-3 level 3 3V/M  
IEC-801-4 level 3 2KV  
IEC-801-5 level 3 2KV

**G-1-6: MECHANICAL SPECIFICATION**

✧ **DC output pin assignment**

Pin#	Signal	Pin#	Signal
1	+5V	6	GND
2	+5V	7	GND
3	+5V	8	+12V
4	GND	9	+12V
5	GND		

✧ **Dimension (unit: mm)**

133.5 x 83.8 x 38.0 (L x W x H)

**G-2: DC POWER SUPPLY**

If the DISPLAY PAC-PPCsystem is accommodated with a DC power supply, the DC used in the DISPLAY PAC-PPC system is a 90 watts forced air cooling power supply.

**G-1: INPUT/OUTPUT SPECIFICATIONS AT 50° C**✧ **Input voltage**

The range of input voltage is from 18Vdc to 36Vdc.

✧ **Max. Input/Output current**

Rated Load			Max Output		
+5V	+12V	-12V	+5V	+12V	-12V
10A	2.5A	0.5A	12A	4A	1A

**H-2: GENERAL SPECIFICATIONS**✧ **Ripple and noise**

Less than 50mV@+5V and less than 100mV@+/-12V

✧ **Line regulation**

The line regulation for each output is less than +/-1%, while measuring at rated loading and +/-10% of input voltage changing

✧ **Load regulation**

Less than +/-1%@+5V and +/-5%@+/-12V

✧ **Over Voltage Protection:**

The trip point is around 5.7V ~ 7V output

✧ **Efficiency:**

Higher than 70%

✧ **Altitude**

0 ~ 10,000ft

✧ **Safety:**

Designed to meet the following standards

UL 1950

VDE EN60 950

CSA 22.2 No. 234

✧ **EMI:**

Meets FCC docket 20780 curve "B", EN55022 "B"

- ✧ **Dimension (W\*H\*D)**  
89\*39\*152.4mm
- ✧ **DC input connectors:**  
2 positions terminal block
- ✧ **DC output connectors:**  
Molex 5273~07A or equivalent
- ✧ **Operating temperature:**  
-20° to 70° C  
(Operating curve will occur 50° to 70° C)
- ✧ **Storage temperature:**  
-25° to 85° C