



GE Fanuc Automation

Programmable Control Products

VersaPoint™ I/O System Profibus-DP NIU

User's Manual

GFK-1911A

February 2002

Warnings, Cautions, and Notes as Used in this Publication

Warning

Warning notices are used in this publication to emphasize that hazardous voltages, currents, temperatures, or other conditions that could cause personal injury exist in this equipment or may be associated with its use.

In situations where inattention could cause either personal injury or damage to equipment, a Warning notice is used.

Caution

Caution notices are used where equipment might be damaged if care is not taken.

Note

Notes merely call attention to information that is especially significant to understanding and operating the equipment.

This document is based on information available at the time of its publication. While efforts have been made to be accurate, the information contained herein does not purport to cover all details or variations in hardware or software, nor to provide for every possible contingency in connection with installation, operation, or maintenance. Features may be described herein which are not present in all hardware and software systems. GE Fanuc Automation assumes no obligation of notice to holders of this document with respect to changes subsequently made.

GE Fanuc Automation makes no representation or warranty, expressed, implied, or statutory with respect to, and assumes no responsibility for the accuracy, completeness, sufficiency, or usefulness of the information contained herein. No warranties of merchantability or fitness for purpose shall apply.

The following are trademarks of GE Fanuc Automation North America, Inc.

Alarm Master	Genius	PowerTRAC	Series Six
CIMPLICITY	Helpmate	ProLoop	Series Three
CIMPLICITY 90-ADS	Logicmaster	PROMACRO	VersaMax
CIMSTAR	Modelmaster	Series Five	VersaPoint
Field Control	Motion Mate	Series 90	VersaPro
GENet	PowerMotion	Series One	VuMaster
			Workmaster

Chapter 1	Introduction.....	1-1
	Features	1-2
	Advantages.....	1-2
	I/O Station Capacity.....	1-2
	What's In This Manual.....	1-3
	Other Documents You'll Need.....	1-4
	Example Plant	1-5
Chapter 2	The Profibus NIU	2-1
	The Profibus System	2-2
	Typical Profibus-DP VersaPoint I/O Station	2-2
	Structure of a VersaPoint I/O Station.....	2-3
	The Profibus-DP Network Interface Unit.....	2-4
	Features.....	2-4
	Items Used with the NIU	2-5
	Ordering Information.....	2-5
	Connectors on the NIU.....	2-6
	Profibus Connector	2-6
	Power Connector	2-7
	NIU Power.....	2-7
	DIP Switches on the NIU	2-8
	LEDS on the NIU.....	2-9
	NIU Specifications.....	2-10
Chapter 3	VersaPoint Modules.....	3-1
	Modules in a VersaPoint Station.....	3-2
	Permitted VersaPoint Devices	3-3
	Input/Output Modules.....	3-4
	Terminal Points.....	3-4
	Power Losses for I/O Modules.....	3-5
	Analog Modules.....	3-6
	Power Terminal Modules.....	3-7
	Segment Terminal Modules.....	3-8
	Parts of a VersaPoint Module.....	3-9
	The Electronics Base.....	3-10
	Diagnostic and Status Indicators.....	3-11
	Module Color Coding	3-11
	Status LEDs and I/O Points	3-12
	Connectors	3-13
	Module Dimensions	3-15

Contents

Chapter 4	Installation	4-1
	Parts of a VersaPoint I/O Station	4-2
	End Plate.....	4-2
	End Clamps.....	4-2
	Planning Module Sequence in the I/O Station	4-3
	Locations for Analog Modules	4-3
	Power for the Station.....	4-4
	Electrical isolation	4-5
	Dangerous voltage!.....	4-5
	Setting the NIU Switches	4-6
	Keying Connectors and Modules	4-7
	Installing Modules on the DIN Rail	4-8
	Removing Modules.....	4-9
	Replacing a Module.....	4-9
	Connecting Unshielded Cables	4-10
	Connecting Shielded Cables.....	4-11
	Connecting Shielded Cables to the Shielded Terminal Strip	4-11
	Repositioning the Shield Clamp	4-12
	Grounding	4-13
	Grounding the NIU and Power Modules	4-13
	Required Additional Grounding.....	4-13
	Installing the Profibus Cable	4-14
	Profibus Cable Specifications	4-14
	The Profibus Cable Connector.....	4-15
	Shielding the Profibus Cable	4-15
	Bus Termination	4-16
	Connecting Power at the NIU	4-17
	Providing the 24V Segment Supply (US) at the NIU.....	4-17
	Fusing for Short Circuit Protection.....	4-17
	Replacing Power and Segment Terminal Fuses	4-18
	Connecting Sensors and Actuators.....	4-19
	Connecting Discrete Devices.....	4-19
	Connections for Discrete Input Modules	4-19
	Connections for Discrete Output Modules.....	4-19
	Connecting 2-Wire Discrete Sensors and Actuators	4-20
	Connecting 3-Wire Discrete Sensors and Actuators	4-20
	Connecting 4-Wire Discrete Sensors and Actuators	4-21
	Connecting Analog Devices.....	4-22
	Connecting Field Devices to an Analog Input Module.....	4-22
	Connecting a Thermocouple Analog Input Module.....	4-22
	Connecting Field Devices to an Analog Output Module	4-23

	Danger of creating ground loops!	4-23
	Connection of actuators for Signal Cables Longer than 10 Meters (32.8 Ft)	4-23
	Module Labeling	4-24
Chapter 5	Power for the Station	5-1
	Supply of the Profibus-DP Network Interface Unit	5-2
	The Logic Circuit: U _L	5-3
	The Analog Circuit: U _{ANA}	5-3
	The Main Circuit: U _M	5-4
	Segment Circuit: U _S	5-5
	Electrical Isolation	5-8
	Electrical Isolation: Profibus	5-8
	Electrical Isolation: I/O	5-8
	Electrical Isolation: Discrete Modules	5-9
	Electrical isolation: Analog module	5-10
	Electrical isolation: Other	5-11
	Summary of I/O Module Current Consumptions	5-12
	VersaPoint Power Consumption Example	5-13
Chapter 6	Diagnostics	6-1
	Local Diagnostics	6-2
	LEDS on the Network Interface Unit	6-2
	Possible LED combinations	6-2
	Determining the Error Cause and Remedy from the NIU LEDs	6-3
	Power and Segment Terminal LEDs	6-8
	I/O Module LEDs	6-9
	Local Diagnostics Example	6-10
	Example Station for Error Identification	6-10
	Diagnostics on the Profibus Master	6-12
	Profibus Standard Diagnostics	6-12
	Profibus – Device-Specific Diagnostics	6-15
Chapter 7	Configuration	7-1
	Configuration of the NIU	7-2
	Powerup Autoconfiguration	7-2
	NIU DIP Switches	7-3
	Configuration of the Profibus Master	7-4
	Example Configuration	7-6
	Example Hardware	7-6
	NIU Configuration	7-7
	Profibus Master Configuration	7-8
	Settings Tab	7-9
	Slave Information Tab	7-11

Contents

	Data Area Tab.....	7-13
Appendix A	Reference Data	A-1
	I/O Station Information	A-2
	Ambient Conditions	A-3
	Mechanical Demands	A-4
	Noise Immunity Test.....	A-4
	Electrical Specifications.....	A-5
	Cables.....	A-7
	I/O Modules	A-7
	Air and Creepage Distances	A-8
	Test Voltages.....	A-9
Appendix B	Glossary.....	B-1
Appendix C	Output Module Derating	C-1
	Power Loss of the Housing Within the Operating Temperature Range Depending on the Ambient Temperature.....	C-2
	Power Loss of the Housing	C-3
	Permissible Operating Temperature Range.....	C-4
Appendix D	The NIU GSD File	D-1

Features

Characteristic VersaPoint features are:

- Modules can be easily installed/interconnected without tools.
- Automatic creation of isolated groups, current, data, and safety circuits
- Open, flexible, and modular structure
- Modules of varying point counts can be combined to create a VersaPoint station that optimizes unit space while minimizing unit cost.

Advantages

VersaPoint design offers the following advantages:

- Reduced control cabinet space.
- The amount of costly parallel wiring is reduced. Within a station, voltage and data routing can be carried out without additional wiring.
- The modular structure makes it possible to assemble standard function blocks in advance. Different parts of the system can be operated independently of one another. This means that pretests can be carried out when the system is set up and that the whole system can be adapted and expanded.

I/O Station Capacity

- Up to 63 devices can be connected to an NIU (Depending on power consumption. See chapter 5).
- The sum of all input and output data can be up to 184 bytes per station.

What's In This Manual

This manual contains the instructions and reference information needed to plan and install a VersaPoint I/O Station on a Profibus-DP network.

Chapter 1 is a quick **introduction** to VersaPoint.

Chapter 2. The Profibus NIU, describes the Profibus Network Interface Unit module IC220PBI001, which connects the VersaPoint I/O Station to the Profibus network.

Chapter 3. VersaPoint Modules, describes the parts and dimensions of VersaPoint I/O and power modules.

Chapter 4. Installation, describes basic VersaPoint module installation and cable connections.

Chapter 5 Power for the Station, explains how power is utilized by the station and routed among the modules.

Chapter 6. Diagnostics, describes in detail the indications of the NIU and module LEDs, as well as additional diagnostics features of the VersaPoint station.

Chapter 7. Data Formats, describes the formats of I/O, status, and diagnostic data in the NIU.

Chapter 8. Profibus Communications, describes communications that are controlled by the master through the application program.

Appendix A. Reference Data, summarizes the standard data for a VersaPoint Profibus I/O system..

Appendix B. Glossary explains many of the terms used in this manual.

Appendix C. Output Module Derating, describes how to calculate power loss and operating temperature limits for I/O modules.

Other Documents You'll Need

Each VersaPoint module is fully described in its own datasheet. Module datasheets are provided on CD, and are available online at www.gefanuc.com. The following datasheets that are available as this manual is being released. Check the GEFanuc website for the latest releases, as well as the most up-to-date document versions and other important product information.

Module Number	Module Description	Datasheet Number
Discrete Input Modules		
IC220MDL641	Input 24VDC Positive Logic 2 Points	GFK-1901
IC220MDL642	Input 24VDC Positive Logic 4 Points	GFK-1902
IC220MDL643	Input 24VDC Positive Logic 8 Points	GFK-2000
IC220MDL644	Input 24VDC Positive Logic 16 Points	GFK-2001
IC220MDL661	Input 24VDC Negative Logic 2 Points	GFK-2002
Discrete Output Modules		
IC220MDL721	Output 24VDC Positive Logic 2.0A 2 Points	GFK-1903
IC220MDL751	Output 24VDC Positive Logic 0.5A 2 Ppoints	GFK-2003
IC220MDL752	Output 24VDC Positive Logic 0.5A 4 Points	GFK-1904
IC220MDL753	Output 24VDC Positive Logic 0.5A 8 Points	GFK-2004
IC220MDL754	Output 24VDC Positive Logic 0.5A 16 Points	GFK-1913
IC220MDL761	Output 24VDC Positive Logic 0.5A 2 Points	GFK-2005
Special Function Modules		
IC220MDD840	High-speed Counter 1 In/1 Out 24VDC	GFK-2052
Analog Input Modules		
IC220ALG220	Analog In 15 Bit Voltage/Current 2 Channels	GFK-1906
IC220ALG620	Analog In 16 Bit RTD 2 Channels	GFK-2013
IC220ALG630	Analog In 16 Bit Thermocouple 2 Channels	GFK-2012
Analog Output Modules		
IC220ALG320	Analog Out 16 Bit Voltage/Current 1 Channel	GFK-1907
IC220ALG321	Analog Out 13 Bit Voltage 1 Channel	GFK-1908
IC220ALG322	Analog Out 13 Bit Voltage 2 Channels	GFK-2011
Power and Segment Terminals		
IC220PWR001	Power Terminal 24VDC	GFK-1909
IC220PWR002	Power Terminal Fused 24VDC	GFK-2006
IC220PWR003	Power Terminal Fused with Diag. 24VDC	GFK-2007
IC220PWR011	Segment Terminal 24VDC	GFK-1910
IC220PWR012	Segment Terminal Fused 24VDC	GFK-2008
IC220PWR013	Segment Terminal Fused W/Diag 24vdc	GFK-2009
IC220PWR014	Segment Terminal Elec Fused 24vdc	GFK-2010

Example Plant

The following example provides an illustration of how the VersaPoint I/O System may be applied. This example highlights the distributed nature of the VersaPoint product line as well as its ability to fit a variety of difficult applications within a single system.

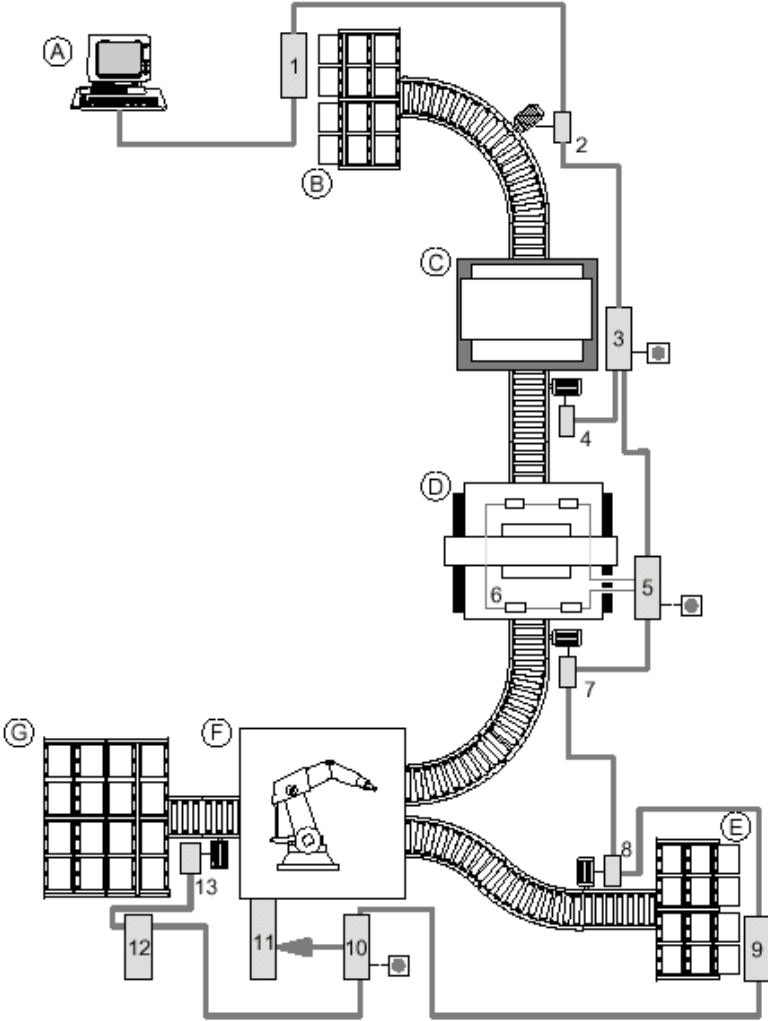

Key:

- A Plant control
- B Material removal area 1
- C Press
- D Punching device
- E Material removal area 2
- F Welding robot
- G Material area 3
- 1, 3, 5, 6, 9, 10, 12 VersaPoint™ stations
- 2, 4, 7, 8, 13 Motor starter
- 11 Robot controller
- Emergency stop switch

This example is a schematic diagram of a plant which is controlled by a host computer.

VersaPoint station 1 modules control the removal of material from area 1.

The motor starter (2) is directly connected to the remote bus. This controls a conveyor belt motor.

VersaPoint station 3 controls the press. As this machine must be particularly well protected, an emergency stop switch has been integrated.

VersaPoint station 5 controls the punching device. Station 6 is connected to station 5, and its modules monitor the status of the press. An emergency stop switch has also been provided here.

Two motor starters are connected at points (7) and (8). They control conveyor belt motors.

VersaPoint station 9 controls the removal of material from area 2.

A robot control system (11) is connected to the communications bus using VersaPoint station 10. An emergency stop switch has also been connected here.

VersaPoint station 12 controls the storage of material in area 3.

Motor starter 13 is directly connected to the remote bus and controls the conveyor belt motor.

This section describes the Profibus Network Interface Unit module IC220PBI001.

- The Profibus System
 - Typical Profibus-DP VersaPoint I/O Station
 - Structure of a VersaPoint I/O Station
- The Profibus-DP Network Interface Unit
 - Features
 - Items Used with the NIU
 - Ordering Information
- Connectors on the NIU
 - Profibus Connector
 - Power Connector
- DIP Switches on the NIU
- LEDs on the NIU
 - Diagnostics
- NIU Specifications

The Profibus System

Profibus is a serial bus system for data transmission between control systems and distributed input and output modules, to which sensors and actuators are connected.

Profibus has a star tree structure. In the Profibus topology the single bus devices can be differentiated by means of their addressing. The communication profiles determine how the devices transmit their data via the bus.

Profibus DP is normally a single master system. It is designed for easy transmission of input and output data and specifically designed for communication between automation systems and the distributed I/O devices.

Typical Profibus-DP VersaPoint I/O Station

A set of interconnected VersaPoint I/O modules can be selected to suit the application, and connected as a slave on a Profibus-DP network. The interface between the network and the modules is a VersaPoint Profibus-DP Network Interface Unit (NIU) module.

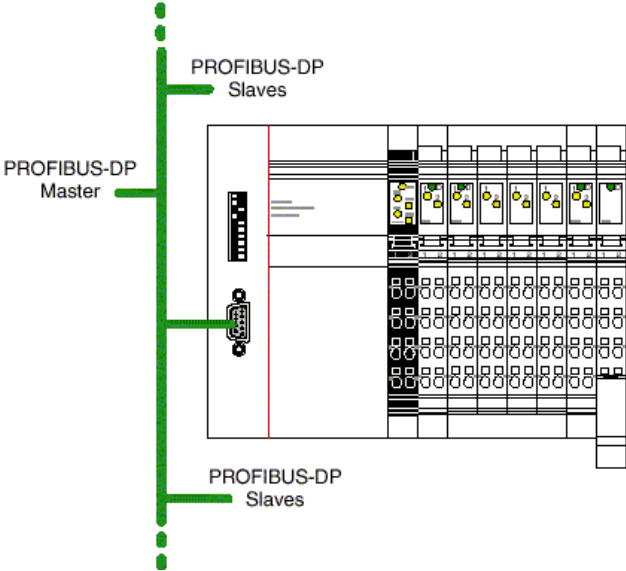

The intelligent wiring method used in the VersaPoint modules allows I/O stations to be constructed easily and quickly. Normally, it is only necessary for the power supply units integrated in the Profibus NIU to be supplied with 24VDC on the input side. They generate the operating voltage required for the NIU itself and for the connected VersaPoint I/O modules.

Structure of a VersaPoint I/O Station

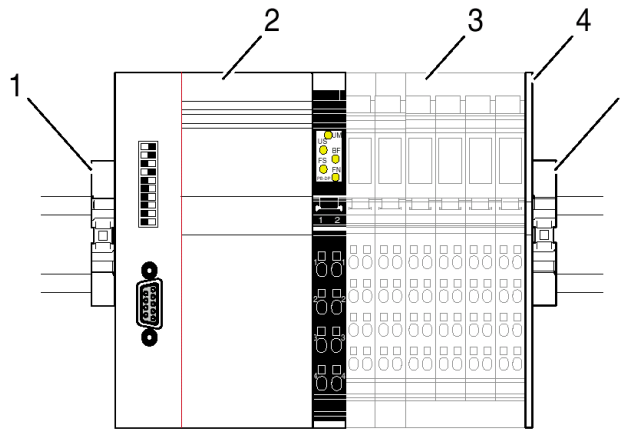

A VersaPoint station with a Profibus NIU consists of:

- (1) End clamps (part number IC220ACC313, supplied with the NIU)
- (2) Profibus-DP Network Interface Unit
- (3) Modules appropriate to the application
- (4) End plate (supplied with the NIU)

The Profibus-DP Network Interface Unit

The VersaPoint™ Profibus-DP Network Interface Unit (NIU), IC220PBI001, is the link between Profibus-DP and the VersaPoint station.

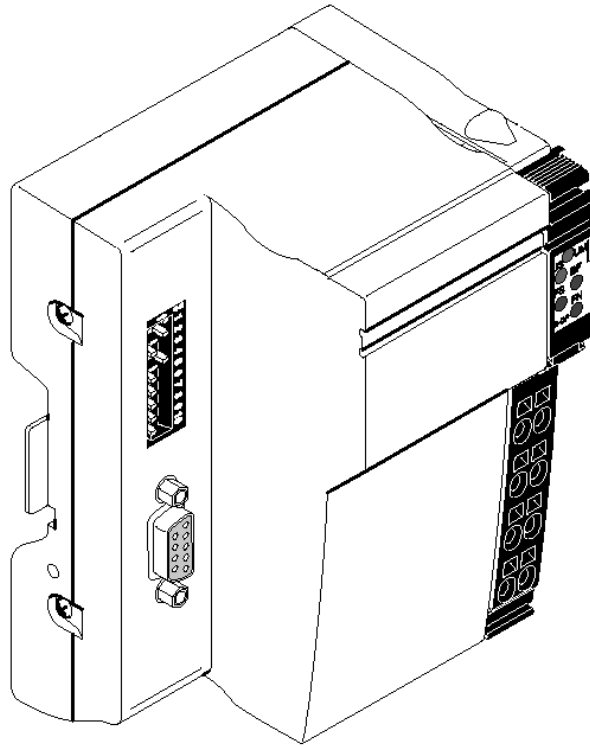

Features

The Profibus-DP Network interface Unit has the following properties:

- A maximum of 63 VersaPoint I/O modules can be connected to Profibus DP by simply plugging them in side by side via the NIU. The NIU and the VersaPoint modules create a station. Check chapter 5 to verify power consumption.
- The sum of all input and output data can be up to 184 bytes per station.
- The NIU can be used at a baud rate of 9.6 kbps for Profibus DP with a maximum total expansion of 1200m (3937ft) or at baud rate of 12Mbps with a maximum of 100m (328 ft). The NIU automatically adjusts to the speed specified by the Profibus master.

Items Used with the NIU

The Profibus NIU (1 below) comes with an end plate (4), a diskette containing the latest GSD file (2), and one set of end clamps (not shown).

The end plate is installed at the end of the VersaPoint station, after the last module. It protects the station from electrostatic discharge and the user from dangerous voltage.

The power connector (3) is ordered separately. See the ordering information below.

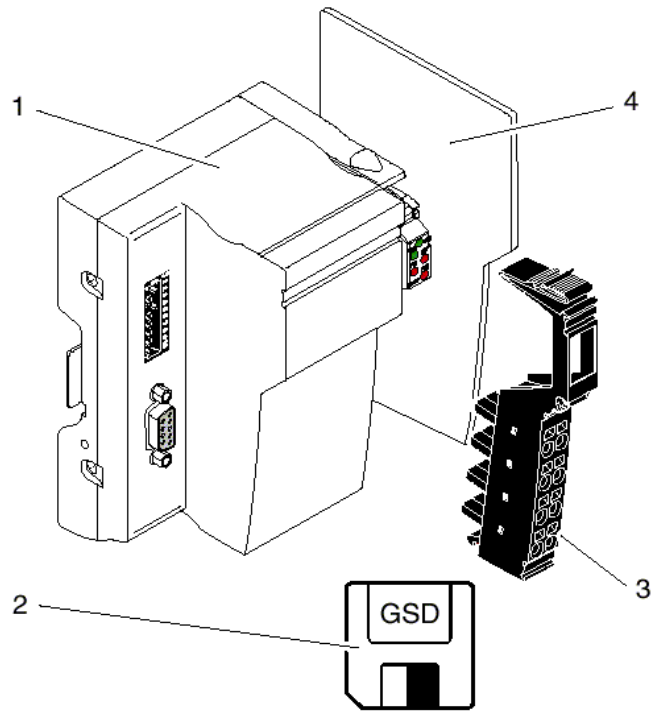

Ordering Information

IC220PBI001	Profibus Network Interface Unit
IC220TBK087	Power connector (quantity 10)

Connectors on the NIU

Profibus Connector

A 9-position, D-SUB connector connects the NIU to the Profibus cable.

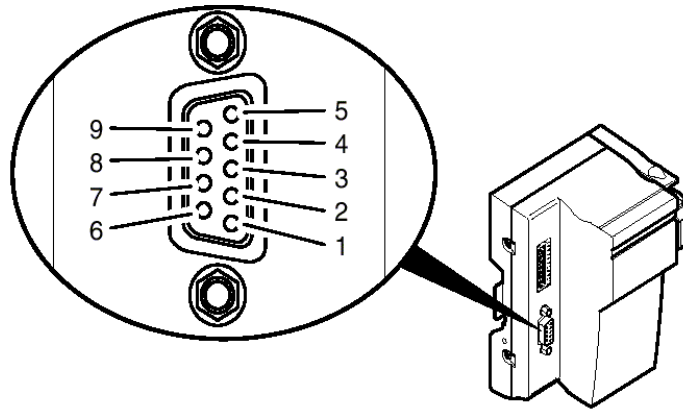

Pin	Assignment
1	Reserved
2	Reserved
3	RxD/TxD-P (+ receive/send data), cable B
4	CNTR-P (control signal for repeater), direction control
5	DGND (reference potential up to 5 V)
6	VP (supply voltage +5 V for terminal resistors)
7	Reserved
8	RxD/TxD-N (- receive/send data), cable B
9	Reserved

Line Terminal Resistors

Since Profibus is a serial bus system in a star-tree structure, the individual branches must be terminated with a terminal resistor. The NIU does not have an integrated resistor of this type. Many Profibus connectors are available with an integrated, switchable resistor. Please contact your GE Fanuc distributor to determine availability.

Power Connector

A power connector (IC220TBK087), ordered separately, is used to make power and ground connections to the NIU.

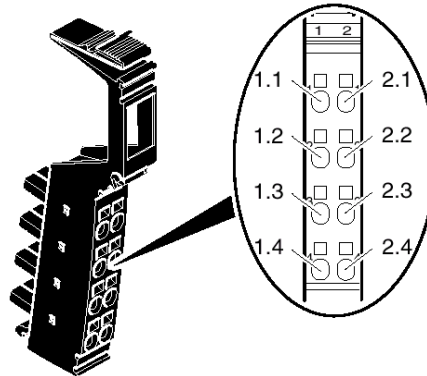

Pin assignments for this connector are listed below:

Assignment of the NIU terminal points

Terminal	Assignment
1.1, 2.1	Segment supply (+24VDC)
1.2, 2.2	Main supply, NIU supply, communications power and interface supply (+24VDC)
1.3, 2.3	Reference potential
1.4, 2.4	Functional earth ground (FE)

NIU Power

The NIU acts as a power terminal, supplying the logic and module power for some or all of the of the I/O modules in the station, as well as the sensors and actuators. Some stations will also use additional power/segment terminals, depending on the needs of the application. See chapter 5 for additional details.

DIP Switches on the NIU

The 10-position DIP switch on the NIU module is used to set the Profibus address and to specify the error response of the NIU.

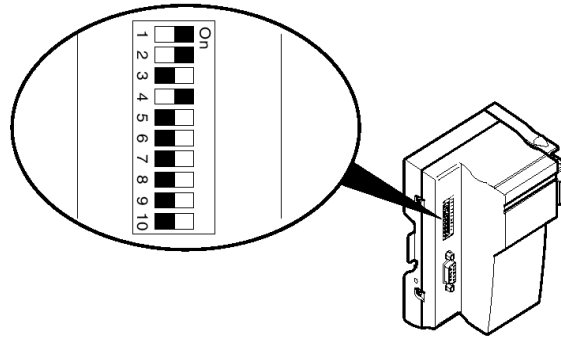

Switches	Meaning
1 to 7	Profibus Address in binary format (= 0 to 127 in decimal format) Switch 1 defines the least significant bit (2^0) and switch 7 defines the most significant bit (2^6).
8	Behavior if a data error occurs in the station (local bus error): ON = data transmission is stopped after a number of attempts. OFF = the station constantly attempts to start data transmission. If DIP switch 8 is in the ON position, a POWER DOWN/POWER UP must be executed on the NIU so that it will restart. There is no automatic restart after the error has been removed.
9 to 10	Reserved, both switches must be in the OFF position.

LEDS on the NIU

The diagnostic LEDs on the NIU indicate the type and location of errors.

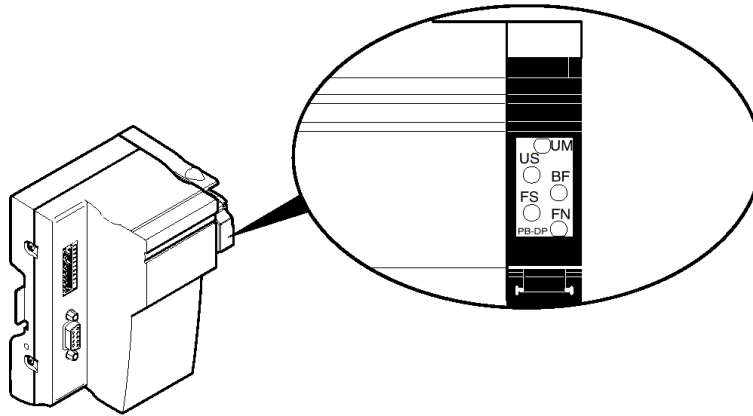

The module is functioning correctly if all of the green LEDs are on. Once errors have been removed, the indicators immediately display the current status.

NIU LED	Color	Meaning
UM	Green	Supply voltage in the main circuit for the NIU, communications power and interfaces present.
US	Green	24 V segment circuit supply present
BF	Red	No communication on Profibus
FS	Red	Defines the function of the FN LED: FS ON: FN indicates the type of error. FS OFF: FN indicates the error number
FN	Red	The number of flashing pulses indicates the type of error or the error number, depending on whether FS is on or not

Diagnostics

The NIU provides the following standard Profibus and device-related diagnostics.

Error Type	Meaning
1	Parameter error on Profibus (SET_PRM telegram)
2	Configuration error on Profibus (CHK_CFG telegram)
3	Configuration error in the station
4	Error within the station
5	Module error

NIU Specifications

General	
Housing dimensions (width x height x depth)	91mm x 120mm x 71.5mm (3.583in. x 4.724in. x 2.815in.)
Degree of protection	IP 20 according to IEC 60529
Class of protection	Class 3 according to VDE 0106, IEC 60536

System Information	
Number of devices per station	63, maximum
Sum of all I/O data per station	184 bytes, maximum
Maximum NIU current for supplying the I/O module logic	2A at U_L
Maximum additional current for supplying the analog terminals	0.5A at U_{ANA}
Profibus-DP Interface	Copper cable (RS-485), connected via SUB-D shield connector; supply electrically isolated, shielding directly connected with functional earth ground.

Chapter 3

VersaPoint Modules

This chapter describes the parts and dimensions of VersaPoint modules.

- Modules in a VersaPoint Station
- Parts of a VersaPoint Module
- The Electronics Base
- Diagnostics and Status Indicators
- Connectors
- Module Labeling
- Module Dimensions

Modules in a VersaPoint Station

A VersaPoint I/O Station begins with of a Network Interface Unit (NIU). The NIU module is the first module on the DIN rail, at the left end of the I/O Station. It is shown here with the required grounding to the DIN rail. See chapter 2 for more information about the Profibus-DP Network Interface Unit. The NIU performs all the data-handling and communications functions for the I/O Station.

The rest of the station is made up of a group of I/O modules that can be selected to exactly fit the needs of the application.

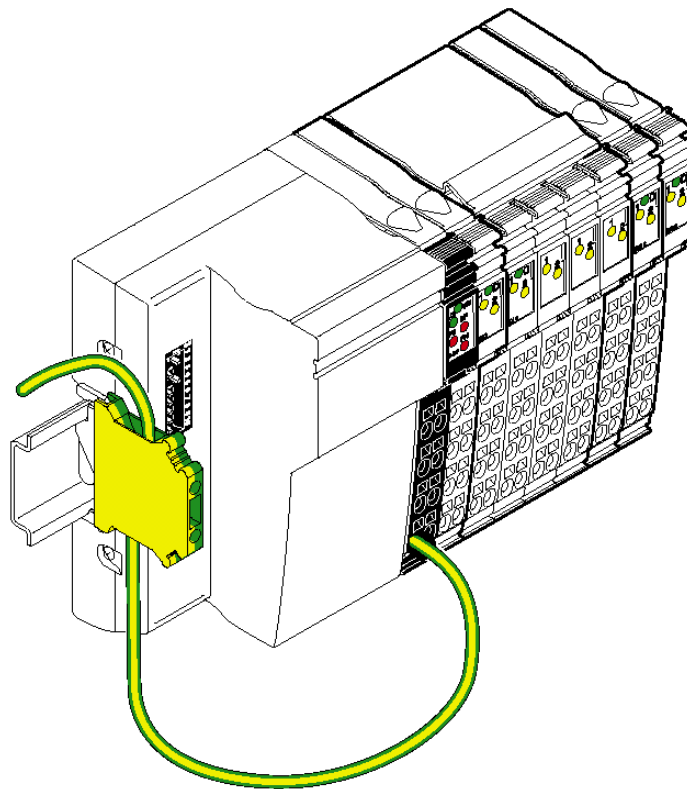

Permitted VersaPoint Devices

The following table lists all VersaPoint modules that can currently be operated with the Profibus-DP NIU.

Module Number	Module Description
Discrete Input Modules	
IC220MDL641	Input 24VDC Positive Logic 2 Points
IC220MDL642	Input 24VDC Positive Logic 4 Points
IC220MDL643	Input 24vdc Positive Logic 8pt
IC220MDL644	Input 24vdc Positive Logic 16pt
IC220MDL661	Input 24vdc Negative Logic 2pt
Discrete Output Modules	
IC220MDL721	Output 24VDC Positive Logic 2.0A 2 Points
IC220MDL751	Output 24vdc Positive Logic 0.5a 2pt(
IC220MDL752	Output 24VDC Positive Logic 0.5A 4 Points
IC220MDL753	Output 24vdc Positive Logic 0.5a 8pt(
IC220MDL754	Output 24vdc Positive Logic 0.5a
IC220MDL761	Output 24vdc Positive Logic 0.5a 2pt
IC220MDL930	Output Relay 3.0A 1 Point
Special Function Modules	
IC220MDD840	High Speed Counter In, 1in/1out 24VDC
Analog Input Modules	
IC220ALG220	Analog In 15 Bit Voltage/Current 2 Channels
IC220ALG620	Analog In 16 Bit Rtd 2ch
IC220ALG630	Analog In 16 Bit Thermocouple 2ch
Analog Output Modules	
IC220ALG320	Analog Out 16 Bit Voltage/Current 1 Channel
IC220ALG321	Analog Out 13 Bit Voltage 1 Channel
IC220ALG322	Analog Out 13 Bit Voltage 2ch
Power and Segment Terminals	
IC220PWR001	Power Terminal 24VDC
IC220PWR002	Power Terminal Fused 24vdc
IC220PWR003A	Power Terminal Fused W/Diag 24vdc
IC220PWR011	Segment Terminal 24VDC
IC220PWR012A	Segment Terminal Fused 24vdc
IC220PWR013A	Segment Terminal Fused W/Diag 24vdc
IC220PWR014A	Segment Terminal Elec Fused 24vdc

Input/Output Modules

Many different types of I/O modules are available. This enables you to build the station in a modular way so that it meets the application's requirements.

Example of a digital input module: IC220MDL642

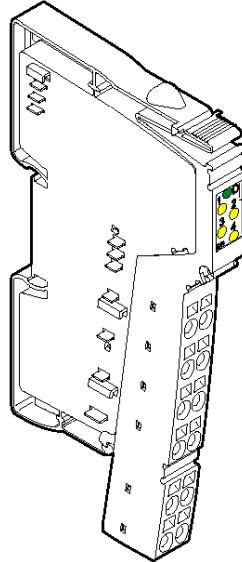

Terminal Points

Depending on the module, input/output modules have terminal points to accommodate 2-, 3-, and 4-wire sensors or actuators. Connections are made to Terminal Strips, which are ordered separately.

Protection

For output modules, surge voltage protection is provided by a fuse in the Power Terminal module, or by an external fuse. The value of the fuse must be such that the maximum load current is not exceeded. For the maximum permissible load current of an I/O module please refer to the module's data sheet.

LEDs

The diagnostic and status indicators on I/O modules provide information on the status of inputs and outputs.

Interfacing to Functional Earth Ground (FE)

There is no interfacing to functional earth ground (FE) in the module, i.e. no direct connection is made with FE when the module is mounted on a grounded DIN rail.

Grounding

A module is grounded via the voltage jumper FE when snapping it onto the previous module. Additional I/O module grounding is not required.

Electrical Isolation

Electrical isolation is not provided by VersaPoint I/O modules. A Power Terminal module must be used for this purpose.

Voltage Ranges

Low-level signal terminals are available for different voltage ranges. To utilize different voltage ranges within a station, a new power terminal must be used for each range.

Power Losses for I/O Modules

Power Loss of the Electronics

The electronics power loss of an I/O module can be calculated following the formula in the module's datasheet. The power loss of the module must not exceed the power loss of the housing.

Power Loss of the Housing

The power loss of the housing indicates the maximum power loss allowed. The maximum power loss is indicated in the module's datasheet. This power loss can be dependent or independent of the ambient temperature. If the power loss of the housing depends on the ambient temperature, a permissible operating temperature range can be calculated using the formula in the module's datasheet.

Permissible Operating Temperature Range

Depending on the power loss of the housing and the power loss of the electronics at a certain current, the temperature up to which the module can be operated with this current can be calculated. Please see the module datasheets for specific information.

See appendix C for example calculations.

Analog Modules

Shield

The connectors of analog modules have a special shield connection to shield the cables.

Configuration

The modules for analog signals operate with a set of default parameters unless they are reconfigured for the application. Each module's defaults are listed in its datasheet.

Diagnostics for Analog Input Modules

Analog input modules have overrange recognition in all measuring ranges. Open circuit diagnostics are also available for some analog input modules. If extended diagnostics are available for a specific module, they are listed in the module's datasheet. Analog error messages include:

- Under-range
- Open circuit
- Measured value invalid
- Configuration invalid
- Terminal defective
- Over-range.

Power Terminal Modules

Power Terminal modules can be placed in an I/O Station to provide additional power, to electrically isolate different circuits, or to create areas with different voltages (ie: 24VDC versus 120VAC) within a station. Multiple Power Terminal modules can be used in an I/O station.

A Power Terminal module supplies voltage for both the main circuit and the segment circuit. See chapter 5 for more details.

Example: 24VDC Power Terminal

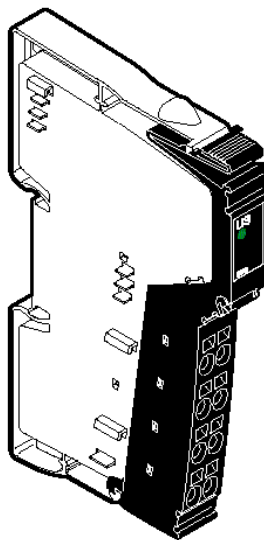

The main power circuit should be protected. If a protected Power Terminal (IC220PWR002 or PWR003) is not used, the 24V supply must be externally protected.

Segment Terminal Modules

Segment Terminal modules can be used to create a segment circuit within the main circuit. The segment circuit allows the separate supply of power outputs (e.g., motor contactors), digital actuators, and digital sensors. With a segment terminal you can also control the segment circuit and switch it on or off, e.g., using emergency stop loops. Segment Terminal modules can only be used with 24V power.

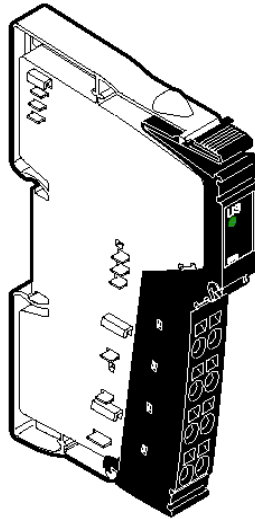

Segment Terminals do NOT provide electrical isolation. A Power Terminal module must be used for that purpose.

Segment terminals can only be used with 24V power.

The connection between the main circuit and the segment / auxiliary supply requires a jumper wire or external switch. Segment terminals have terminal points for the connection of a jumper or switch. When using a standard segment terminal, (IC220PWR011), the segment circuit is not protected! The 24V supply must be externally protected. See "Power Terminals".

Segment terminals with internal fuse protection (IC220PWR012, 013, and 014) are also available.

Parts of a VersaPoint Module

A VersaPoint I/O or power module consists of an electronics base and plug-in connector.

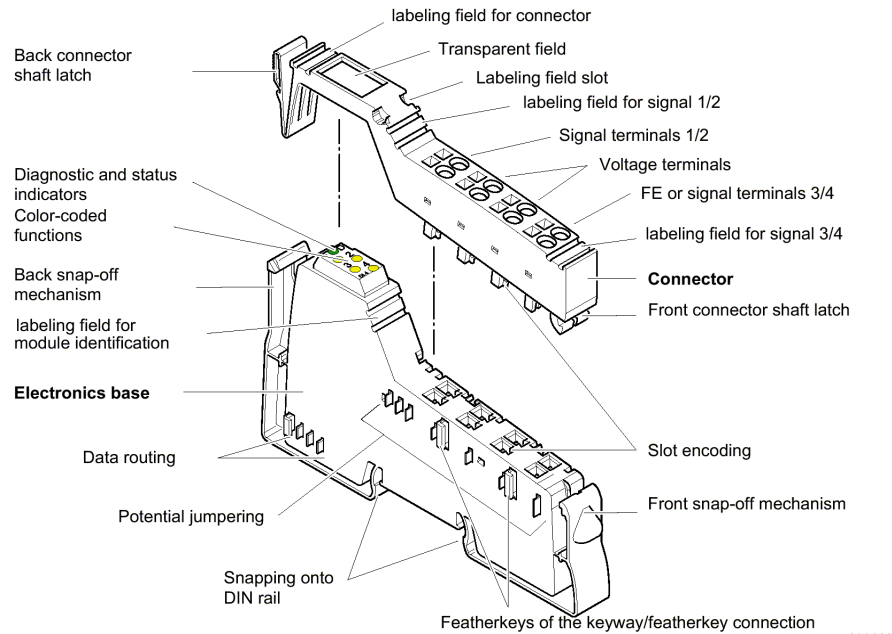

The Electronics Base

The electronics base holds the entire electronics for the VersaPoint module and the voltage and data routing.

As all the modules are snapped onto the DIN rail, there is a secure interface between the modules. Voltage and current for station operation are routed through the jumpers on each module, which are indicated in the following illustration. This functionality is explained in detail in chapter 5.

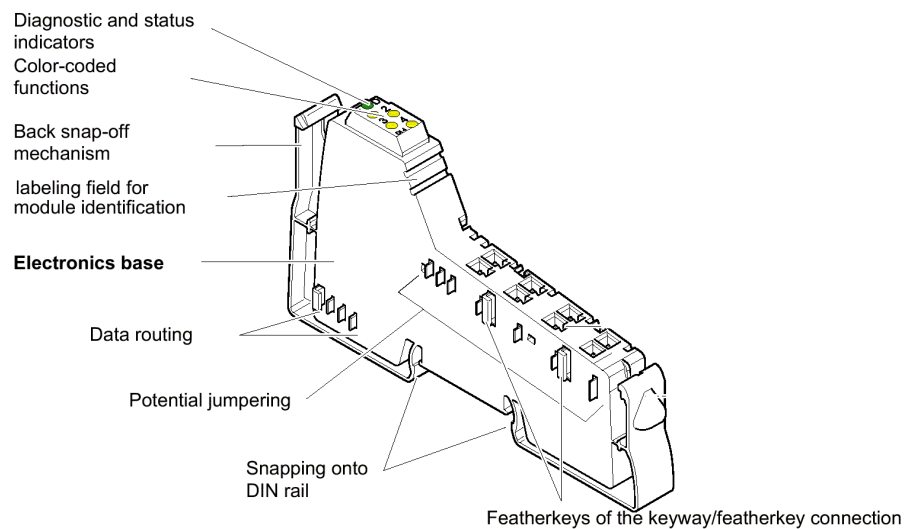

Built-in snapping mechanisms on the electronics base make it easy to install on the DIN rail without the use of tools. (Please see the installation instructions in chapter 4).

Diagnostic and Status Indicators

All modules have diagnostic and status indicators for rapid local error diagnostics.

The diagnostic indicators (red/green) indicate the status of the modules. A module is operating normally if all its Diagnostic (D) LEDs are solid green.

The status indicators (yellow) display the status of the relevant inputs/outputs for the connected device. LEDs are described in detail in chapter 6.

Diagnostic and status indicators

Color-coded functions

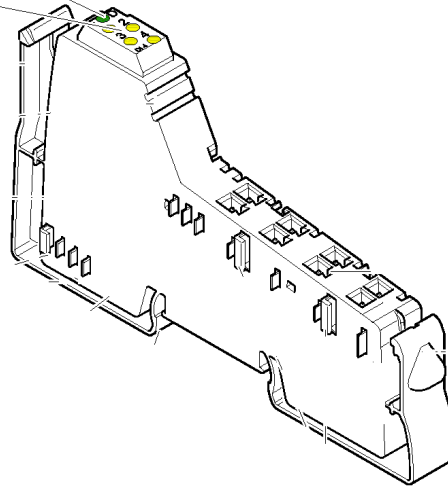

Module Color Coding

The area surrounding each module's LEDs is color-coded to provide an indication of the module's function. The following table explains this color-coding.

Color	Function
Gray	Analog
Blue	Digital - DC
Red	Special function
Orange	Digital mixed
Black	Power terminal / segment terminal / NIU

Status LEDs and I/O Points

The illustration below shows the relationship between the status LEDs on a module and the module inputs or outputs.

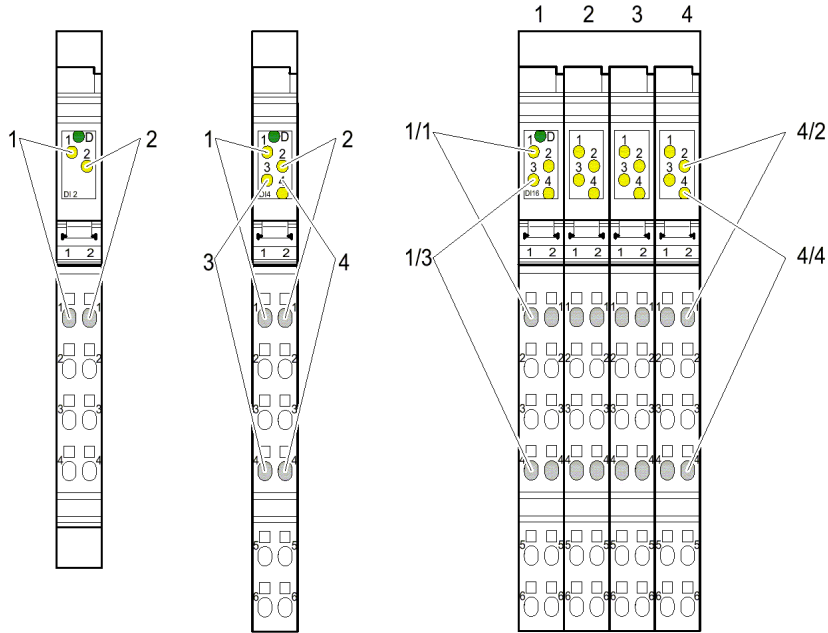

In general, an I/O module's status LEDs appear over their associated terminals. In cases where two I/O points are terminated in the same column (for 4 and 16 point modules), the LED's relative position (top or bottom) indicates the I/O point it is associated with.

For a single-width module with 4 inputs or outputs (middle module in the illustration above), the LEDs and terminal points are associated as follows:

- LED 1 Terminal point 1.1
- LED 2 Terminal point 2.1
- LED 3 Terminal point 1.4
- LED 4 Terminal point 2.4

On the four-slot module, LED 2 on slot 4 is indicated. The LED belongs to input 14 on terminal point 4/2.1 (slot 4 / terminal point 2.1)

Connectors

The connection of the I/O or supply voltages is made by using a connector that can be plugged on or off the modules.

Connector Types

The following connector types are available:

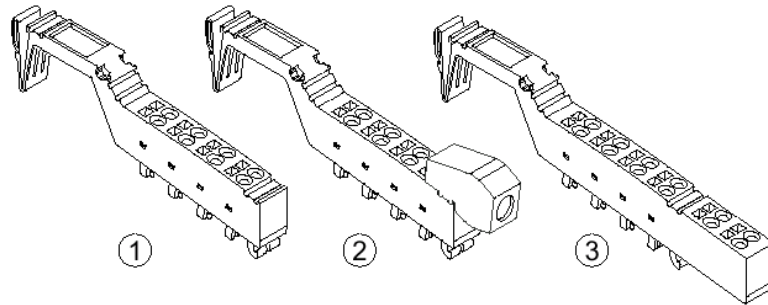

(1) Standard connector (IC220TBK082, 085, 087)

The standard connector is used for the connection of two signals in 4-wire format (e.g., digital input/output signals). The standard connector housing is also used for power and segment terminals and relay terminals, although the types are NOT interchangeable.

(2) Shield connector (IC220TBK061)

This connector is used for signals connected using shielded cables (e.g., analog I/O signals, high-speed counter inputs, network cable). The FE or shielding is connected by a shield clamp.

(3) Extended, connector (IC220TBK122, TBK123)

This connector is used for the connection of four signals in 3-wire format (e.g., digital input/output signals).

Regardless of the width of the electronics base, the connectors are provided with a standard width. Wider modules may require multiple connectors.

Connector Identification

Connectors have terminal points that are color coded corresponding to their functions:

Color	Terminal point signal
Red	+
Blue	-
Green	Functional earth ground

Internal Structure of the Connector

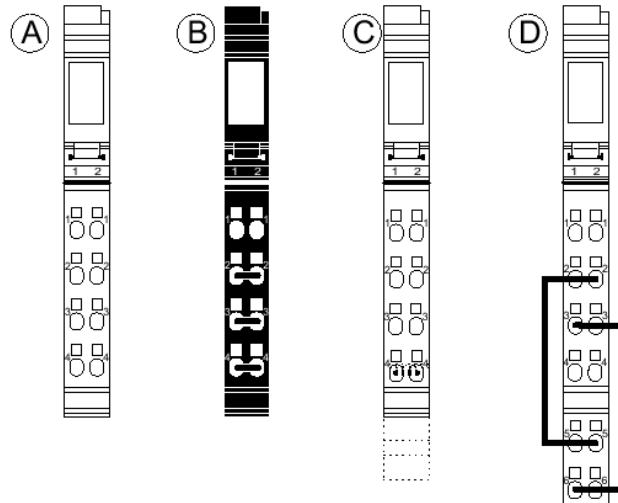

- A Standard connector (IC220TBK082, 085)
- B Connector for power and segment terminals (IC220TBK087)
- C Shield connector (IC220TBK061) for analog modules
- D Extended connector (IC220TBK122, TBK123)

The dark lines shown on connectors B and D above indicate jumper connections. These jumpers are internal to the connectors.

The shield connector is jumpered through the shield connection. All other connectors are jumpered through module point connection.

To avoid a malfunction, only snap a suitable connector on a module that is appropriate for this connector. Refer to the module-specific data sheet to select the correct connectors.

A supply connector must not be placed on a module that is to be used with an extended connector. This will cause a short circuit between two signal module points (1.4 - 2.4).

Place only supply connectors on supply modules. Do not use the standard connectors! When the terminal points are jumpered in the supply connector, power is carried through the jumpering in the connector and not through the printed circuit board of the module.

Module Dimensions

The module dimensions are determined by the dimensions of the electronics base and the dimensions of the connector.

When a connector is plugged in, each module depth is 71.5mm (2.795 in.). The height of the module depends on the connector used.



Connector Dimensions

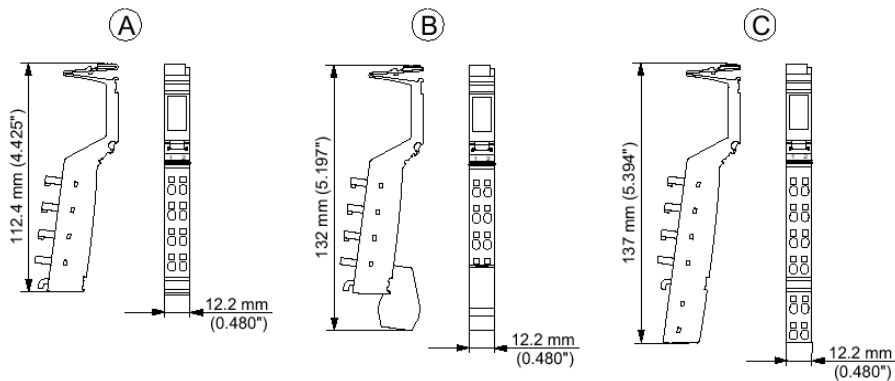

Key:

- A. Standard connector (IC220TBK082, IC220TBK085, IC220TBK087)
- B. Shield connector (IC220TBK061)
- C. Extended connector (IC220TBK122, IC220TBK123)

The depth of the connector does not influence the overall depth of the module.

This chapter describes basic VersaPoint module installation and cable connections. Please refer to chapter 5 for more information about power connections for the I/O Station.

- Parts of a VersaPoint I/O Station
- Planning module sequence in the I/O Station
- Power for the station
- Setting the NIU switches
- Keying
- Installing modules on the DIN rail
- Removing modules
- Connecting unshielded cables
- Connecting shielded cables
- Grounding
- Connecting the Profibus cable at the NIU
- Connecting power at the NIU
- Replacing power and segment terminal fuses
- Connecting sensors and actuators
- Module labeling

Parts of a VersaPoint I/O Station

A VersaPoint station with a Profibus Network Interface Unit consists of:

- (1) End Clamps (supplied with NIU)
- (2) Profibus NIU
- (3) Modules appropriate to the application
- (4) End Plate (supplied with the NIU)

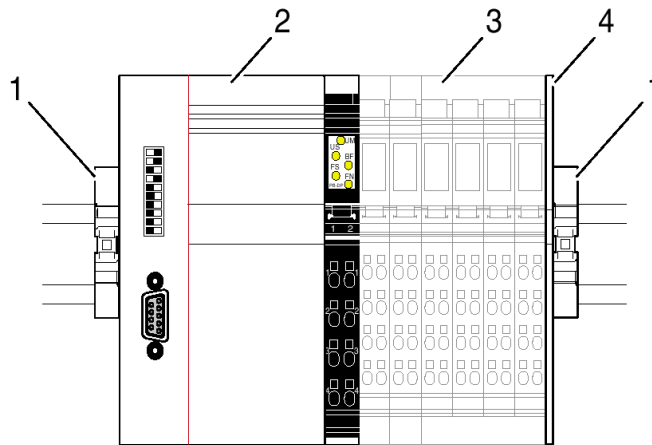

Mount modules side by side on a 35mm (1.378in.) standard DIN rail. No tools are required.

Do not set up the station while the power is connected. Before setting up a VersaPoint station or inserting a module, be sure the entire station is disconnected from the power. Be sure the entire station is reassembled before switching power on.

End Plate

The VersaPoint I/O Station must be terminated using the end plate that is supplied with the Network Interface Unit module. The end plate does not have an electrical function. It protects the station from ESD pulses and the user from dangerous voltages.

End Clamps

Install end clamps on both ends of the station to hold it in place on the DIN rail. End clamps are supplied with the NIU. If additional clamps are required, they are available as GE Fanuc part number IC220ACC313.

Planning Module Sequence in the I/O Station

The NIU is the first module in the station. The sequence of the other modules should be planned carefully. Within a main circuit, place the I/O modules with the highest current consumption (U_S) first. This approach is advantageous in that the high supply current does not flow through the entire main circuit. See chapter 5 for a list of the current consumptions of VersaPoint modules.

Locations for Analog Modules

High current flowing through voltage jumpers U_M and U_S increases the temperature of the voltage jumpers and the inside of the module. Note the following instructions to keep the current flowing through the voltage jumpers of the analog modules as low as possible:

It is recommended that each analog module have a separate main circuit. If this is not possible and it is necessary to use analog modules in a main circuit together with other modules, place the analog modules at the end of the main circuit (to the right of other modules).

This practice is particularly important for the thermocouple module IC220ALG630. Internal module heating falsifies the temperature of the internal cold junction. Therefore, position this module after all of the other modules to minimize the current flowing through all voltage jumpers.

Power for the Station

The DeviceNet NIU receives power from the DeviceNet connection. This DeviceNet power supplies the NIU, and can also supply the logic and analog power for the I/O Station. A station may also include one or more Power Terminal and Segment Terminal modules. Power Terminal modules must be connected to external power. Segment Terminal modules draw their power from the main supply within the station, and are not connected to external power.

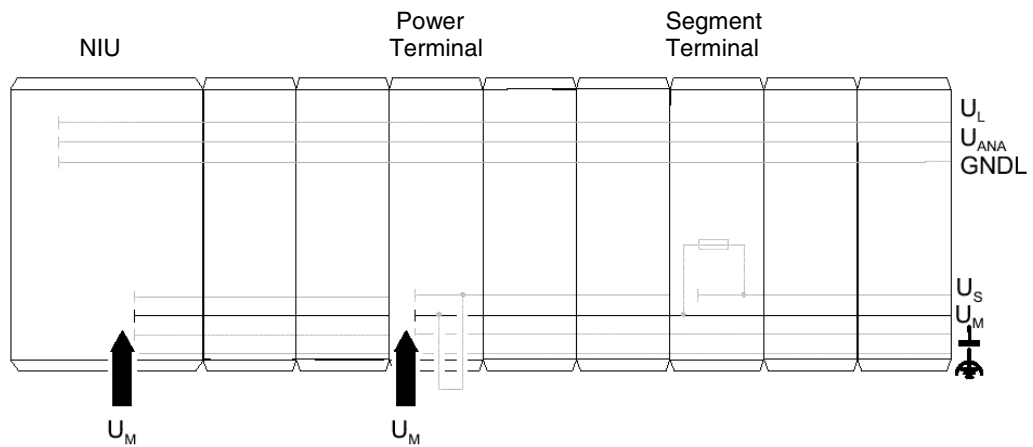

Please see chapter 5 for more information about station power.

Voltage supplies are connected using unshielded cables as described previously.

Electrical isolation

If electrical isolation is required between logic and I/O you must provide the NIU supply U_M and the I/O supply U_S from separate power supplies.

If various electrically isolated areas are required within a VersaPoint station, additional power terminals that draw their current from separate power supplies must be used.

The correct method of providing and distributing power to the station depends on the needs of the application. See chapter 5 for detailed information about power sources and power distribution in the VersaPoint I/O station.

Use power supplies with safe isolation!

Use power supplies that ensure safe isolation between primary and secondary circuit (according to EN 50178).

For additional voltage supply specifications refer to the data sheets of the NIUs and power terminals.

Voltage supplies are connected using unshielded cables as described previously. For the connector assignment of the supply voltage connections please refer to the module-specific data sheets of NIU, power terminals, and segment terminals.

Dangerous voltage!

When the power terminal is removed, the metal contacts are freely accessible. With 120V or 230V power terminals, it should be assumed that dangerous voltage is present. You **must** disconnect power to the station **before removing** a terminal!

If these instructions are not followed, there is a danger of damage to health and danger of a life-threatening injury.

Setting the NIU Switches

Configure the hardware using the 10-position DIP switch on the NIU module.

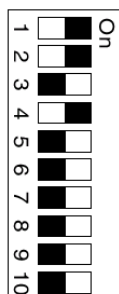

Switches	Meaning
1 to 7	Profibus Address in binary format (= 0 to 127 in decimal format) Switch 1 defines the least significant bit (2^0) and switch 7 defines the most significant bit (2^6).
8	Behavior if a data error occurs in the station (local bus error): ON = data transmission is stopped after a number of attempts. OFF = the station constantly attempts to start data transmission. If DIP switch 8 is in the ON position, a POWER DOWN/POWER UP must be executed on the NIU so that it will restart. There is no automatic restart after the error has been removed.
9 to 10	Reserved, both switches must be in the OFF position.

Keying Connectors and Modules

You can prevent the mismatching of any connector by keying the base and the connector using module keys (ordered separately, IC220ACC005 quantity 100).

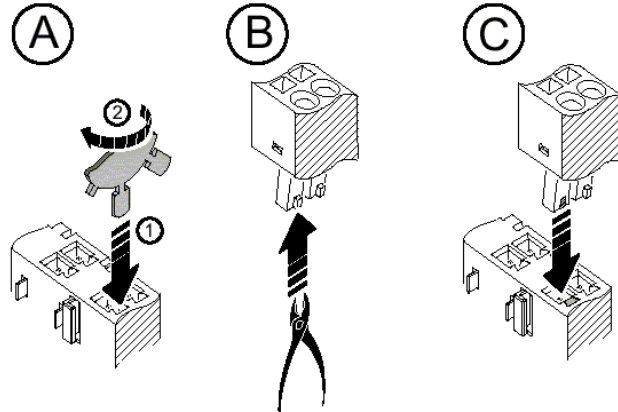

- A. Plug a coding key into the keyway in the base (1) and turn it away from the small plate.
- B. Use a pair of cutters to cut off the keying tab from the connector.

Installing Modules on the DIN Rail

Mount modules side by side on a 35mm (1.378 in.) standard DIN rail.

- First, attach the electronics bases to the DIN rail by pushing the base straight-in towards the rail (1).

Be sure that **all** featherkeys and keyways on adjacent modules are interlocked (2). First, align the featherkey of the module with the keyway of the previous module. Then, attach the new module to the DIN rail by pushing it straight in toward the rail. Do not twist or pivot the module during installation; that may damage the modules.

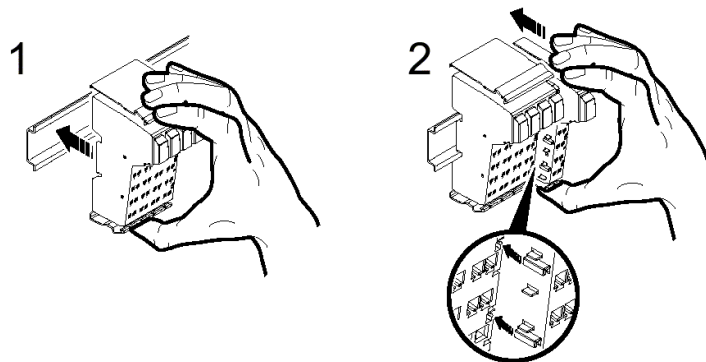

- Next, attach the Terminal Strip to the module.

First, place the front latch in the front snap-on mechanism (3).

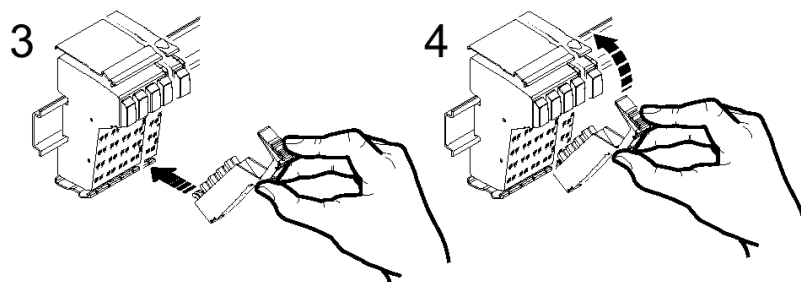

Then pivot the top of the Terminal Strip towards the module until the back latch snaps into place (4).

The keyways of a module do not continue on the Terminal Strip. When snapping on an module, there must be no Terminal Strip on the left-hand side of the module. If a Terminal Strip is present, remove it before installing the next module.

Removing Modules

When removing a module, follow the steps shown below:

- If there is a module label present, remove it (A-1, below).

If the module has more than one Terminal Strip, all of these must be removed. The following describes how a single-slot module is removed.

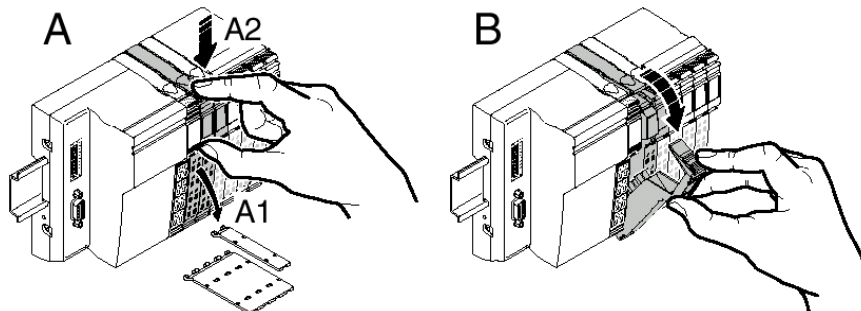

Lift the Terminal Strip by pressing on the connector latch (A-2).

- Remove the Terminal Strip (B).
- Remove the left-adjacent and right-adjacent Terminal Strips of the neighboring modules (C). This prevents the potential routing featherkeys and the keyway/featherkey connection from being damaged and creates more space for accessing the module.

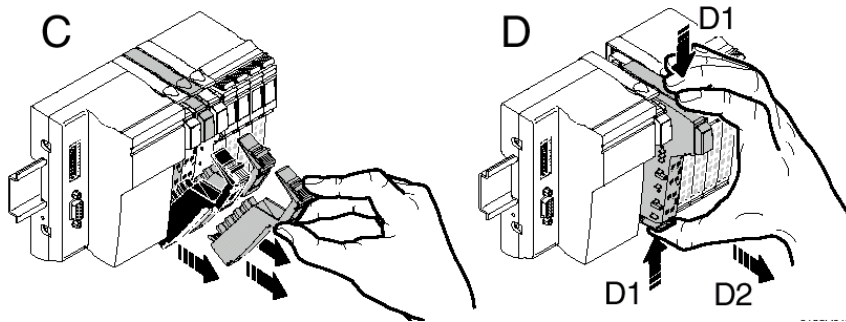

- Press the release mechanism, and remove the module from the DIN rail by pulling it straight back (D-2).
- To remove the NIU, the left end clamp must be removed first.

Replacing a Module

If you want to replace a module within the VersaPoint station, reverse the removal procedure above.

Connecting Unshielded Cables

Unshielded cables for I/O devices and supply voltages are connected using the spring-clamp terminals. Signals up to 250VAC/DC and 5A with a conductor cross-section of 0.2mm² to 1.5mm² (AWG24 – 16) can be connected.

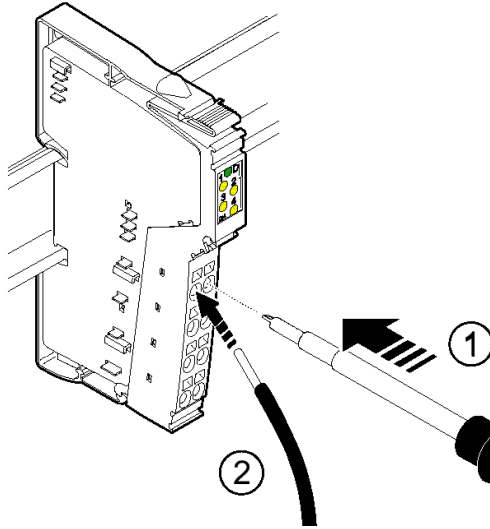

For terminal assignments, please consult the appropriate module data sheet.

Follow these steps when wiring:

- Strip 8mm (0.3in.) off the cable. Module wiring is normally done without ferrules. However, it is possible to use ferrules. If using ferrules, make sure they are properly crimped.
- Push a screwdriver into the slot for the appropriate connection (#1 above) so that you can plug the wire into the spring opening.
- Insert the wire (#2 above). Pull the screwdriver out of the opening. The wire is clamped.

After installation, you should label the wires and Terminal Strips as described later in this chapter.

Connecting Shielded Cables

Observe the following when installing shielding:

- Strip the outer cable sheath to the desired length (#1a below). The appropriate length depends on the connection position of the wires and whether there should be a large or a small space between the connection point and the shield connection.



- Shorten the braided shield to 15mm (0.6 in.) (#1 above).
- Fold the braided shield back over the outer sheath. (#2 above)
- Remove the protective foil.
- Strip 8mm (0.3in.) off the wires. (#2 above)

Connecting Shielded Cables to the Shielded Terminal Strip

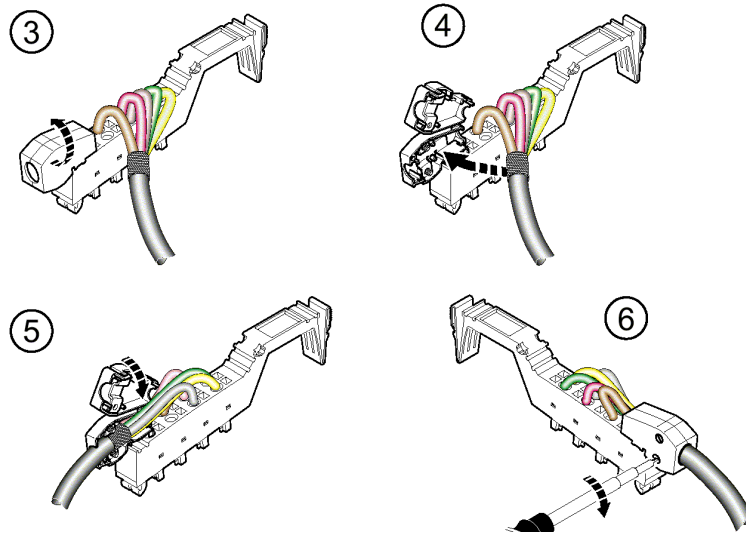

- Open the shield connector (#3 above).
- Check the orientation of the shield clamp in the Shielded Terminal Strip and change its position if necessary (see below for instructions).
- Place the cable with the folded braided shield in the shield connector. (#4 above)
- Close the shield connector (#5 above).
- Fasten the screws for the shield connector using a screwdriver. (#6 above).

Repositioning the Shield Clamp

The shield clamp (2a, below) in the shield connector can be adjusted to accommodate thin or thick cable. The shield connection is delivered with the clamp positioned for the connection of thicker cables (#2 below). In that position, the bend in the clamp faces away from the cable. For thinner cables the bend in the clamp faces towards the cable (#6 below).

If you need to change the alignment of the shield clamp, proceed as shown below:

- Open the shield connector housing (#1).
- Remove the clamp (#3), turn the clamp according to the cross-section of the cable (#4) and then reinsert the clamp. (#5)

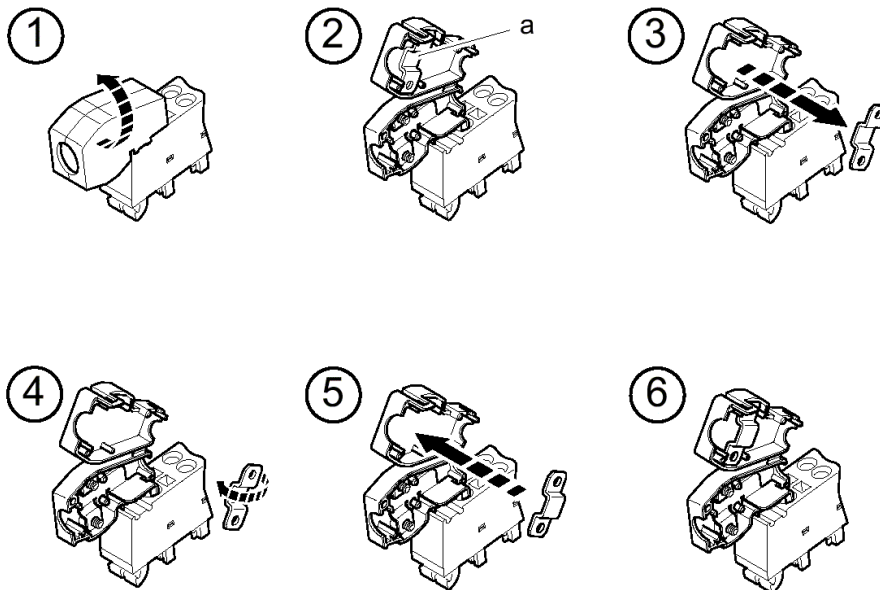

Grounding

All devices in a VersaPoint station must be grounded so that possible signal interference is shielded and discharged to ground. A wire of at least 1.5mm² (16 AWG) must be used for grounding.

Grounding the NIU and Power Modules

The NIU, power terminals, and segment terminals have an FE spring (metal clip) on the bottom of the electronics base. These springs create an electric connection to the DIN rail. VersaPoint I/O modules are automatically grounded via the FE voltage jumper when they are connected to other modules. The FE voltage jumper (functional earth ground) runs from the NIU through the entire VersaPoint station. The function of FE is to discharge interference. It does not provide shock protection.

Required Additional Grounding

To ensure a reliable ground connection even if the DIN rail is dirty or the metal clip damaged, GE Fanuc recommends grounding the NIU to a DIN rail-mounted grounding terminal block, via the FE terminal point.

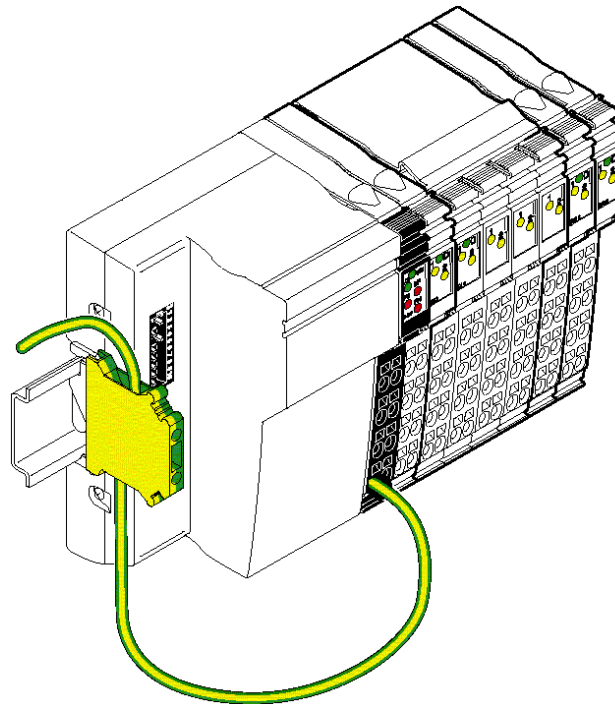

Installing the Profibus Cable

When laying the Profibus cable, note the following:

- Do not lay signal and bus cables parallel to power cables or in bundles with power cables.
- Lay Profibus cables and cables with direct voltages > 60V and alternating voltages > 25V in separate bundles or cable channels.
- Always lay signal cables in one channel, following the shortest route.
- Avoid extending the Profibus cables with connectors.
- Do not lay Profibus cables in bundles with telephone lines and cables leading to potentially explosive areas.
- Avoid branch lines.

Refer to the following cable specifications, connector description, and instructions for cable shielding and bus termination.

Profibus Cable Specifications

The proper cable for a Profibus network is a shielded twisted pair cable. Profibus cable is available from Siemens parts distributors and sold as "Profibus Network Cable". The twisted pair cable consists of a Green and a Red wire. Below are some of the cable characteristics of Profibus cable.

Profibus Network Cable	Siemens part # 6XV1-830
Profibus 9-pin Connector	Siemens part # 6ES7972
Impedance	135 to 165 Ohms (3 to 20 MHz)
Capacity	< 30 pF per meter
Resistance	< 110 Ohms per Kilometer
Wire Gauge	> 0.64 mm
Conductor Area	> 0.34 mm ²

For data rates up to 500 kbits/second, follow the stub recommendations in the Profibus technical standard. At 1500 kbits/second the overall drop capacity should be less than 0.2nF. Maximum length of the stub at 1500 kbits/second is 6.6 meters.

The Profibus Cable Connector

Most Profibus devices, including the VersaPoint Network Interface Unit, provide the Profibus standard female 9-pin D subminiature connectors. Cable connectors are available from Siemens parts distributors as "Profibus 9-pin D connectors". These connectors provide termination resistors and a switch on the connector to enable/disable termination.

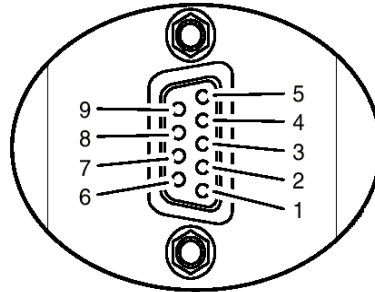

The connectors label the connections for the twisted pair as cable A and cable B. The following table illustrates the proper assignment of wire to connector to pin to signal.

Wire Color	Connector	Pin	Signal
Red wire	B	3	RxD/TxD-P
		5	DGND
		6	VP
Green wire	A	8	RxD/TxD-N

Shielding the Profibus Cable

Cable shielding is recommended at higher baud rates. Cable shields must be attached at each device via the connector shells.

When mounting the NIU in the cabinet, connect the cable shield of the connected Profibus cable with a shield bus via cable clamps. Use an appropriate shield clamp for this.

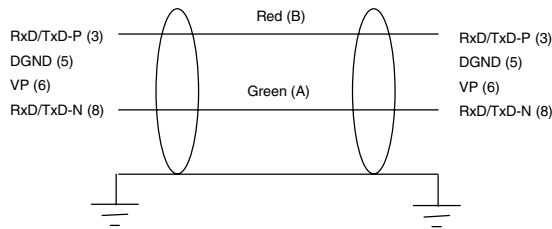

Bus Termination

Termination resistors are needed, as defined in DIN 19245 Part 1 section 3.1.2.5.

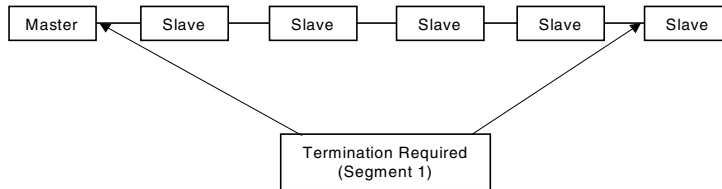

One terminator must be applied at each end of a network segment.

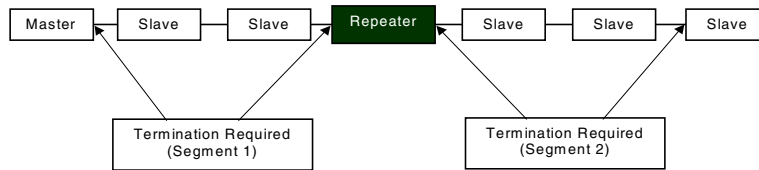

Generally, termination is provided in commercially-available Profibus standard network connectors. Some connector vendors provide termination capability in the connector and a switch on the connector to enable/disable termination. Some connector vendors provide both terminated and unterminated connectors.

Important: For proper network termination, it is essential that the terminating devices maintain power. Power is provided by the device on Pin 6 and Ground on Pin 5. If power is lost to either terminating device, the network may not operate correctly. Generally, the lone network master device is one of the terminating devices. Therefore, a loss of power to the network master renders the network inoperable anyway. The other terminating device may be a critical slave device which must maintain power or a separately powered, stand-alone terminator. These stand-alone devices are commercially available.

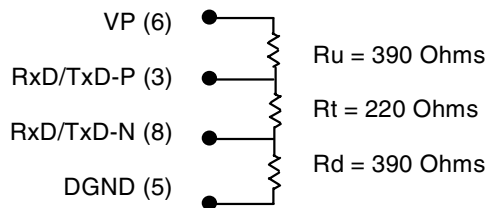

Connecting Power at the NIU

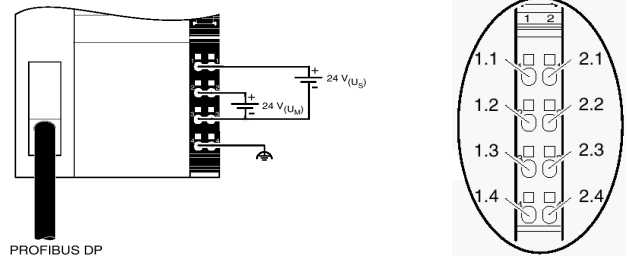

Terminal	Assignment
1.1, 2.1	Segment supply (+24VDC)
1.2, 2.2	Main supply, NIU supply, communications power and interface supply (+24VDC)
1.3, 2.3	Reference potential
1.4, 2.4	Functional earth ground (FE)

Providing the 24V Segment Supply (U_S) at the NIU

You can supply/generate the segment voltage at the NIU or a Power Terminal module. There are several ways of providing the segment voltage on the NIU:

1. You can provide the segment voltage separately on the terminal points 1.1/2.1 and 1.3/2.3 (GND) of the Power Terminal Strip.
2. You can jumper the connections 1.1/2.1 and 1.2/2.2 to ensure that the segment circuit is supplied from the main circuit.
3. With a switch between the terminal points 1.1/2.1 and 1.2/2.2 you can create a segment circuit (e.g., an emergency stop circuit).

CAUTION: To minimize heat generation, use both of the adjacent contacts to provide the main voltage and to provide/tap the segment voltage.

Fusing for Short Circuit Protection

Both the segment supply U_S and the main supply U_M have the same reference potential. Therefore, an isolated voltage area on the I/O side cannot be created. Both the main supply and the segment supply are protected against polarity reversal and surge voltage.

CAUTION: The main supply and the segment supply integrated into the NIU do not have short circuit protection. The user must provide short circuit protection. The rating of the fuse must be such that the maximum permissible load current is not exceeded.

Replacing Power and Segment Terminal Fuses

For VersaPoint Power and Segment Terminal modules that have built-in fusing, if a fuse is not present or defective, you must insert or exchange the fuse. Follow the steps below to replace a fuse:

1. Lift the fuse lever (A).
2. Insert the screwdriver behind a metal contact of the fuse (B).
3. Carefully lift the metal contact of the fuse (C).
4. Carefully lift the fuse on one side and remove it by hand (D).
5. Insert a new fuse (E).
6. Push the fuse lever down again until it snaps into place with a click (F).

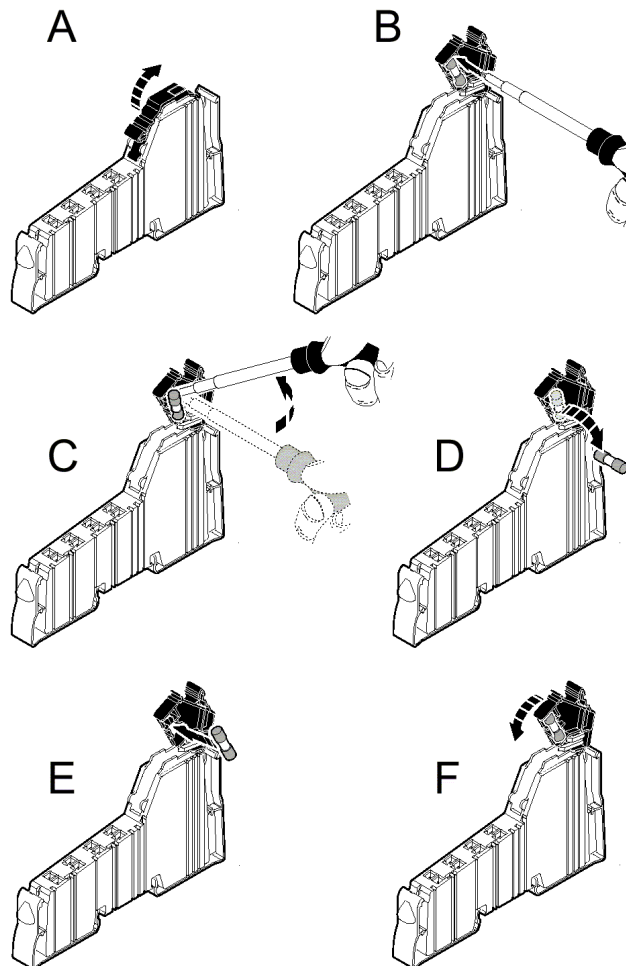

Connecting Sensors and Actuators

Each module-specific data sheet indicates the appropriate Terminal Strip(s) for that module.

Connecting Discrete Devices

VersaPoint discrete modules allow the connection of sensors and actuators in 2-wire, 3-wire, or 4-wire technology (ability varies by module). A single Terminal Strip can support the following connection methods:

- 2 sensors or actuators in 2-, 3-, or 4-wire technology
- 4 sensors or actuators in 2- or 3-wire technology
- 2 sensors or actuators in 2- or 3-wire technology with shielding (for analog sensors or actuators)

The tables below summarize the connection options for 24V modules. A connection example is given in every module-specific data sheet.

Connections for Discrete Input Modules

Connection	Abbreviation	2-Wire	3-Wire	4-Wire
Sensor signal I _N	IN	X	X	X
Sensor supply U _S / U _M	US (+24V)	X	X	X
Ground (GND)	GND (⊥)	–	X	X
Ground/FE shielding	FE	–	–	X

Connections for Discrete Output Modules

Connection	Abbreviation	2-Wire	3-Wire	4-Wire
Actuator signal OUT	OUT	X	X	X
Actuator supply U _S	US (+24V)	–	–	X
Ground (GND)	GND (⊥)	X	X	X
Ground/FE shielding	FE	–	X	X

- X Used
 -- Not used

In the following figures U_S is the supply voltage. Depending on which voltage jumper is accessed, the main voltage U_M or the segment voltage U_S is the supply voltage.

Connecting 2-Wire Discrete Sensors and Actuators

Example A below shows the connection of a 2-wire sensor. The sensor signal is carried to the module point IN1. Sensor power is supplied through the voltage U_s .

Example B below shows the connection of an actuator. The actuator power is supplied through output OUT1. The load is switched directly by the output. The maximum current carrying capacity of the output must not be exceeded.

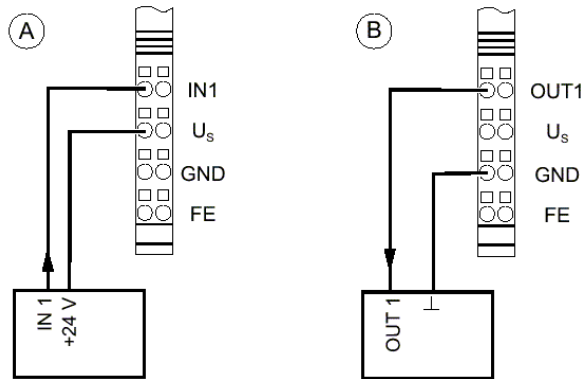

Connecting 3-Wire Discrete Sensors and Actuators

Example A below shows the connection of a 3-wire sensor. The sensor signal is carried to the module point IN1 (IN2). The sensor is supplied with power using the module points U_s and GND.

Example B below shows the connection of a shielded actuator. The actuator is supplied through output OUT1 (OUT2). The load is switched directly by the output. The maximum current carrying capacity of the output must not be exceeded.

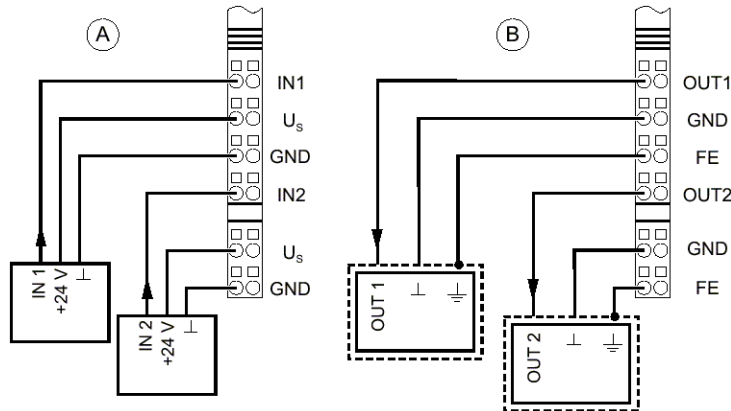

Connecting 4-Wire Discrete Sensors and Actuators

Example A below shows the connection of a shielded 3-wire sensor. The sensor signal is carried to the module point IN1. The sensor is supplied with power using the module points U_s and GND. The sensor is grounded with the FE (Functional Earth Ground) module point.

Example B below shows the connection of a shielded actuator. By providing the supply voltage U_s , even actuators that require a separate 24V supply can be connected directly to the module. The maximum current carrying capacity of the output must not be exceeded.

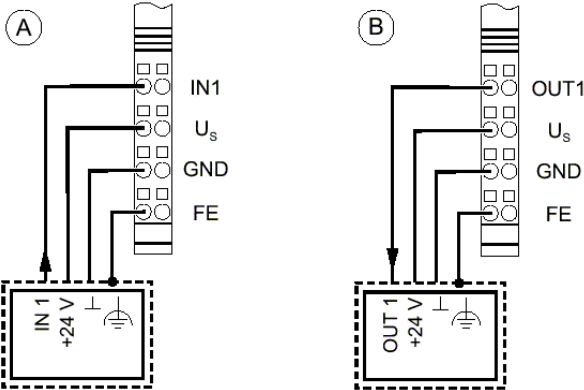

Connecting Analog Devices

Refer to the module datasheets for detailed instructions when connecting analog sensors and actuators. For maximum noise immunity, always use shielded, twisted-pair cables.

Connecting Field Devices to an Analog Input Module

For an analog input module:

- Within the module, grounding is connected with FE through an RC element
- For cable up to 10m (32.8 ft), connect the shield to the Shielded Terminal Strip as described previously.
- For cable longer than 10m (32.8 ft), connect the sensor directly to PE (protective earth ground) as shown below.

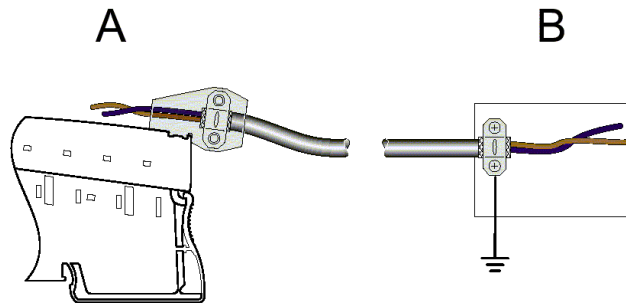

- When connecting the shield of the sensor with PE potential, ensure a large surface connection.

When using analog modules with more than one analog channel, there are different ways of connecting the shield. This depends on the wire diameter.

1. The preferred method for all wire diameters is to use a Terminal Strip with dual shield connectors (IC220TBK062).
2. Use a multi-wire cable for the connection of both sensors and connect the shield as described above to the shield connector (IC220TBK061).
3. Use a thin cable for the connection of each sensor and connect the shields of both cables together to the shield connector.

Connecting a Thermocouple Analog Input Module

1. Connect the shield to the shield connector.
2. Cut the braided shield off at the sensor or cover it with shrink tubing.

Connecting Field Devices to an Analog Output Module

For maximum noise immunity, always connect analog actuators with shielded, twisted-pair cables. For an analog output module:

- Connect the shield to the shield connector as described previously.
- When connecting the shield with FE potential, ensure a large surface connection.

Danger of creating ground loops!

The shielding must be directly connected with ground potential at only one point.

For **cable lengths exceeding 10 meters (32.8 ft.)** the actuator side should always be isolated by means of an RC element.

- The capacitor C should typically have values of 1nF to 15nF.
- The resistor R should be at least 10MΩ.

Connection of actuators for Signal Cables Longer than 10 Meters (32.8 Ft)

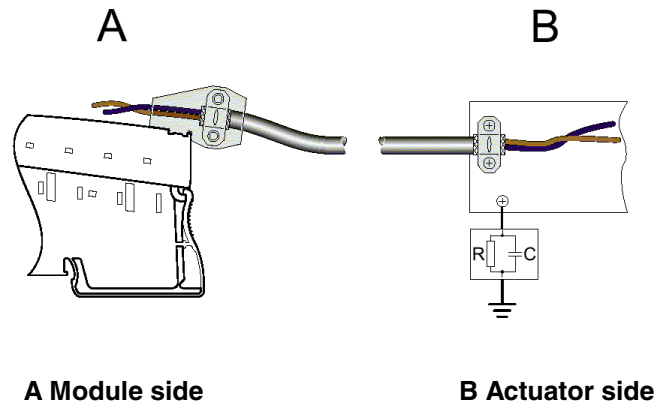

Module Labeling

You can identify the slots, terminal points, and connections using point labels and module labels.

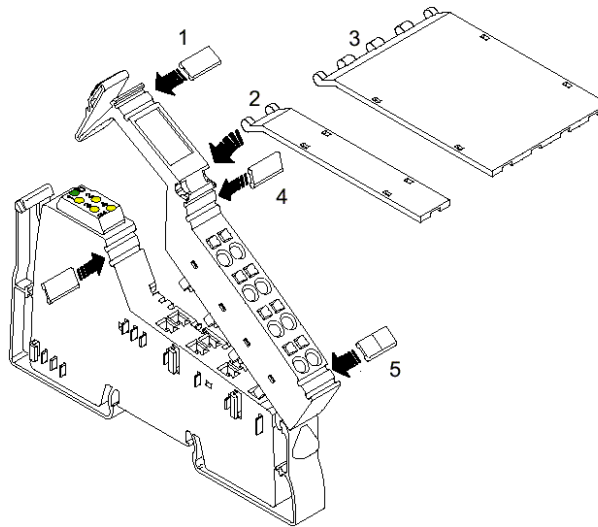

Various options are available for labeling slots and module points:

1	Each Terminal Strip can be labeled individually with point labels (numbered labels: IC220ACC003 numbered 1-100, qty 10 sets, or blank labels: IC220ACC004, qty 1000).
2 / 3	Another option is to use module labels. These are available in two widths, to cover one Terminal Strip (IC220ACC001, qty.10) or four Terminal Strips (IC220ACC002, qty. 10).
	The Terminal Strip has a keyway for attaching a module label. A small latch holds the module label in place.
4 / 5	Each signal can be labeled individually using point labels. On an Extended Double Terminal Strip, the higher keyway (4) is designed for labeling signals 1/2 and the lower keyway (5) is for signals 3/4. (Numbered labels: IC220ACC003 numbered 1-100, qty 10 sets, or blank labels: IC220ACC004, qty 1000).

Chapter 5

Power for the Station

This section explains how power is utilized by the station and routed among the modules.

- Supply of the Profibus Network Interface Unit
 - The Logic Circuit
 - The Analog Circuit
 - The Main Circuit
 - Segment Circuit
 - Example of a Circuit Diagram
- Electrical Isolation
 - Electrical Isolation: Profibus
 - Electrical Isolation: I/O
 - Electrical Isolation: Discrete Modules
 - Electrical Isolation: Analog Modules
 - Electrical Isolation: Other
- Summary of I/O Module Current Consumptions
- Station Configuration Example

Supply of the Profibus-DP Network Interface Unit

Logic and field power are distributed among VersaPoint I/O modules on several dedicated power circuits.

These are:

- The main power circuit (U_M), which powers all modules that do not need to be separately switchable from the main circuit. The main power circuit begins at the power terminal integrated into the NIU. It may also include additional Power Terminal modules as appropriate.
- The segment voltage (U_S) is drawn from the main power circuit at the NIU, at a Power Terminal module, or at a Segment Terminal module. A 24V segment circuit can be used to power I/O modules that must be separately switchable from the main voltage. One or more segment circuits might be created for discrete input modules without individual short-circuit protection, for discrete output modules, and to control power switches and contactors.
- Logic Voltage (U_L) is generated from the main power circuit at the NIU and provides communications power for all I/O modules in the station. This voltage is not augmented by the addition of extra power terminals.
- Analog Voltage (U_{ANA}) is supplied by the NIU and used to power the analog modules in the I/O Station. This voltage is not augmented by the addition of extra power terminals.

Each of these power circuits is described in this section.

The **main power** U_M and the **segment voltage** U_S for the station are connected at the Network Interface Unit. The main power generates internal voltages for the logic circuit U_L and analog signals U_{ANA} . The segment voltage supplies the sensors and actuators.

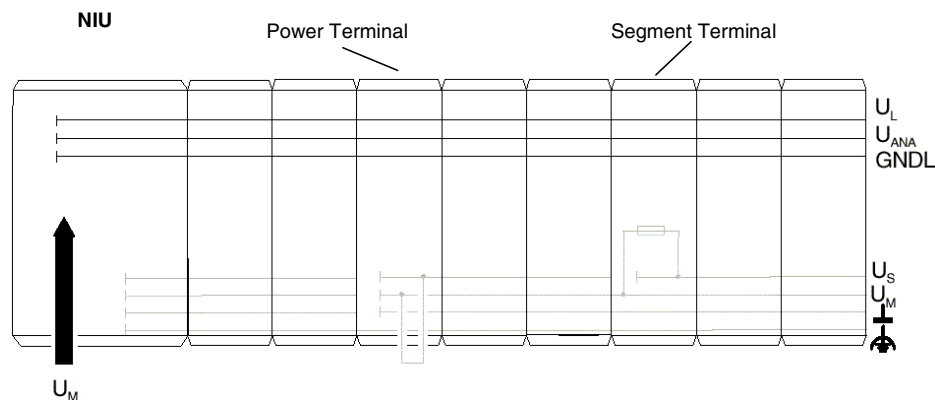

The Logic Circuit: U_L

The logic circuit with communications power U_L starts at the NIU. The logic circuit is fed through all modules of a station. The logic circuit cannot be supplied via another supply terminal.

<i>Function: Logic Circuit U_L</i>	Provides the communications power for all modules in the station.
<i>Voltage of U_L</i>	7.5V
<i>Generation of U_L</i>	U_L is generated from the main power U_M of the NIU.
<i>Current carrying capacity of U_L</i>	2A, maximum. (See Summary of I/O Module Current Consumptions at the end of this chapter). The communications power is not electrically isolated from the 24V input voltage for the NIU.

The Analog Circuit: U_{ANA}

Power for the analog modules (here also called analog voltage) U_{ANA} is supplied at the NIU. It is fed through all the modules in a VersaPoint station.

<i>Function: Analog Circuit U_{ANA}</i>	Provide power for analog modules
<i>Voltage of U_{ANA}</i>	24V.
<i>Generation of U_{ANA}</i>	U_{ANA} is generated from the main power U_M of the NIU.
<i>Current carrying capacity of U_{ANA}</i>	0.5A, maximum. (See Summary of I/O Module Current Consumptions at the end of this chapter).

The Main Circuit: U_M

The main circuit with the main power U_M starts at the NIU or a power terminal.

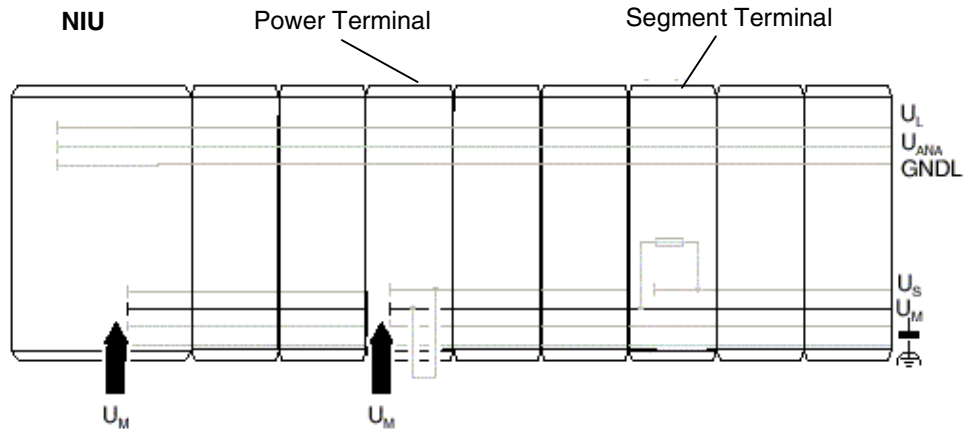

U_M is fed through all subsequent modules until it reaches the next power terminal. A new circuit that is electrically isolated from the previous one begins at the next power terminal.

Multiple power terminals can be used within one station.

Function of U_M

Several independent segments can be created within the main circuit. The main circuit provides the main power for these segments. For example, a separate supply for the actuators can be provided in this way.

Voltage of U_M

The voltage in this circuit must not exceed 250VAC.

Current carrying capacity of U_M

The current carrying capacity is 8A, maximum (total current with the segment circuit). If the limit value of the voltage jumpers U_M and U_S is reached (total current of U_S and U_M), a new power terminal must be used.

Generation of U_M

For many applications, the capacity of the U_M supply integrated into the Profibus NIU is sufficient to power the station. If necessary, U_M can also be supplied via a power terminal. A power terminal must be used if:

1. Different voltage ranges (e.g., 120 V) are needed
2. Electrical isolation is required.
3. The maximum current carrying capacity of a voltage jumper (U_M or U_S) is reached.

Segment Circuit: U_S

A segment circuit or auxiliary circuit with segment voltage U_S starts at the NIU or at a supply terminal (power terminal or segment terminal). It is fed through all subsequent modules as far as the next supply terminal.

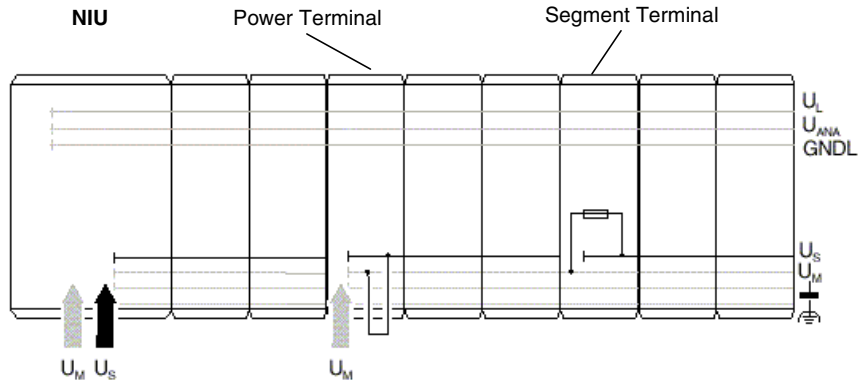

Function of U_S

You can use several segment terminals within a main circuit, and therefore segment the main circuit. It has the same ground reference as the main circuit. This means that circuits with different fuses can be created within the station without external wiring.

Voltage of U_S

24VDC maximum.

Current carrying capacity of U_S

8A, maximum (total current with the main circuit). If the limit value of a voltage jumper U_M or U_S is reached (total current of U_S and U_M), a new power terminal must be used. (See summary of I/O module current consumptions in this chapter).

The segment circuit supplies all modules that need to be separately switchable from the main voltage e.g., on an emergency stop. This includes discrete input modules without individual short-circuit protection, discrete output modules, and auxiliary supply voltage for controlling power switches and contactors. The segment circuit can be switched off or fused using the emergency stop or segment terminals. It has the same ground reference as the main circuit. This means that emergency stop circuits or circuits with different fuses can be created within the station without external wiring.

Generation of U_S

There are various ways of providing the segment voltage U_S :

1. You can supply the segment voltage at the NIU or at a power terminal.
2. You can tap the segment voltage from the main power at the NIU or a power terminal using a jumper or a switch.
3. You can use a segment terminal and tap the segment voltage from the main power.

With 120V and 230V voltage levels, segments cannot be created. In this case, only the main circuit is used.

Example of a Circuit Diagram

The diagram below shows part of a VersaPoint I/O Station.

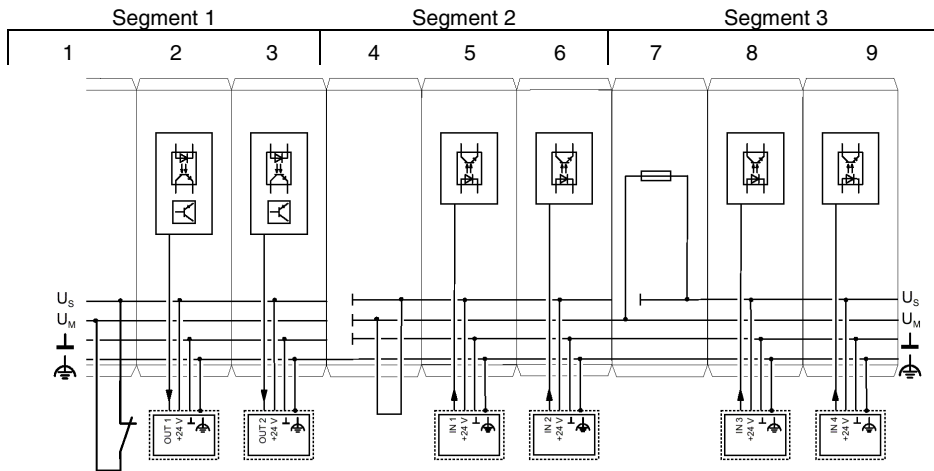

Module	Type	Part Number	Max. Current Consumption of the Example Terminal from U_s
1	Network Interface Unit	IC220PBI001	
2	Discrete output module	IC220MDL753	4A
3	Discrete output module	IC220MDL721	4A
4	Power terminal	IC220PWR001	–
5	Discrete input module	IC220MDL643	2A
6	Discrete input module	IC220MDL642	1A
7	Fused Segment terminal	IC220PWR012	
8	Discrete input module	IC220MDL641	500mA
9	Discrete input module	IC220MDL641	500mA

- Segment 1** The NIU supply and the main supply U_M are supplied at the NIU (1).
- The supply voltage of the logic U_L and the supply voltage of the analog modules U_{ANA} are generated from the NIU supply (U_L and U_{ANA} are not considered in the figure).
- Electrical isolation between logic and I/O is given through the separate supply of the NIU and U_M . The segment supply U_S for segment 1 is tapped from the main supply U_M . In this case, this happens through a switch located at the corresponding terminal points of the bus module. The digital output modules (2 and 3) are located in a switched segment circuit.
- As the two output modules consume a maximum of 8A, the main voltage U_M must be reinjected behind these two modules to prevent the current carrying capacity of the voltage jumpers from being exceeded.
- Segment 2** The supply voltage U_M is reinjected at the power terminal (4).
Using a jumper, the segment voltage U_S for segment 2 is tapped at this module from the main voltage U_M .
- Segment 3** Segment 3 is created through a segment terminal with fuse (7).
In a segment terminal with fuse the segment voltage is automatically tapped from the main voltage. This segment circuit is protected by an internal fuse. Because of this fuse the circuit is suitable for the connection of input terminals without internal fusing (8 and 9) or for the connection of output terminals (not present in this example).

Segment Circuits have the advantage of isolating errors

- In this example, a short circuit in input module 8 would not affect the modules of the first or second segment. Because of the fuse in segment terminal 7, only the third segment is switched off.
- If an error occurred in the system, the discrete output modules 2 and 3 could be switched on or off without affecting modules of other segments.

Electrical Isolation

The Profibus-DP NIU and the VersaPoint system have a defined voltage and grounding concept. This avoids an undesirable effect on I/O devices in the logic area, suppresses undesirable compensating currents and increases noise immunity.

Electrical Isolation: Profibus

The Profibus interface is electrically isolated from the station electronics. The shield of the Profibus cable is directly connected with the function earth ground spring (FE spring), which is located on the bottom of the NIU. This spring has no connection with the second FE spring in the module, which can also be found on the bottom of the NIU, directly under the terminal points. This spring is directly connected with both terminal points of the power connector. When the two functional earth ground springs have been snapped on, they have contact to the DIN rail and are used to lead off interference, rather than as a protective earth ground. To ensure discharge of interference, even for dirty DIN rails, connect the functional earth ground directly to terminal points 1.4 or 2.4. This also sufficiently grounds the I/O Station up to the first segment terminal.

Electrical Isolation: I/O

The NIU does not provide electrical isolation between the main circuit, U_M , and the VersaPoint module communications power. U_M (24V) is not electrically isolated from U_L (7.5V) or U_{ANA} (24V).

It is only possible to isolate both voltages separately using isolated power options for the main power U_M and the I/O voltage U_S on the NIU, because both voltages have the same ground reference.

If isolation of these voltages is required, a separate power terminal with a separate isolated power supply must be used. Providing isolated power supplies for U_M and U_S on the same power terminal is insufficient as the two circuits share a ground.

Electrical Isolation: Discrete Modules

Isolation of the I/O circuit of a discrete module from the communications power is only ensured if a separate IC220PWR001 power terminal is used and the voltages for the power terminal and the NIU are provided by isolated power supply units. The 24V power supply units must not be connected to one another.

The power terminal interrupts all voltage jumpers from the previous terminal and creates the voltage jumpers for the main circuit U_M , the segment circuit U_S and reference potential of the supply voltage GND. An example of this is shown below.

Example: Interruption/creation of the voltage jumpers with a power terminal

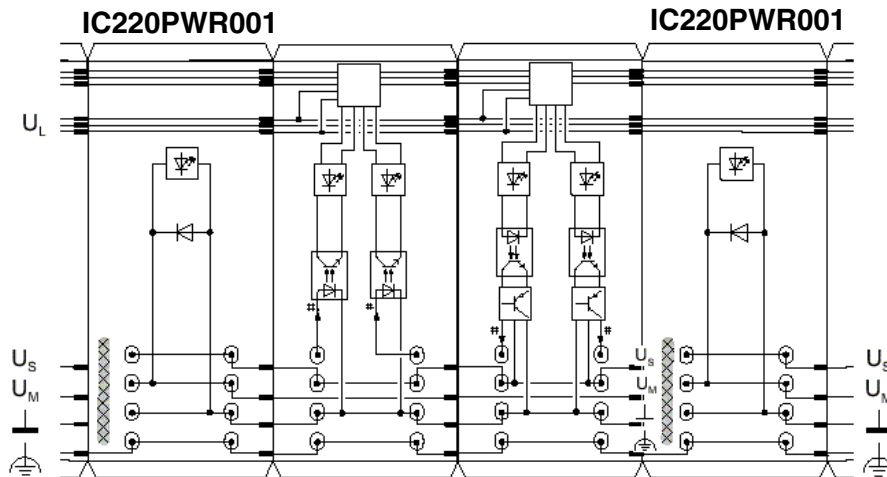

The areas hatched in the figure show the points at which the voltage jumpers are interrupted.

Electrical isolation: Analog module

The I/O circuit of an analog module receives electrically isolated power from the 24V supply voltage U_{ANA} . The power supply unit with electrical isolation is a component of an analog module. The voltage U_{ANA} is carried through in each module and is available to the next module.

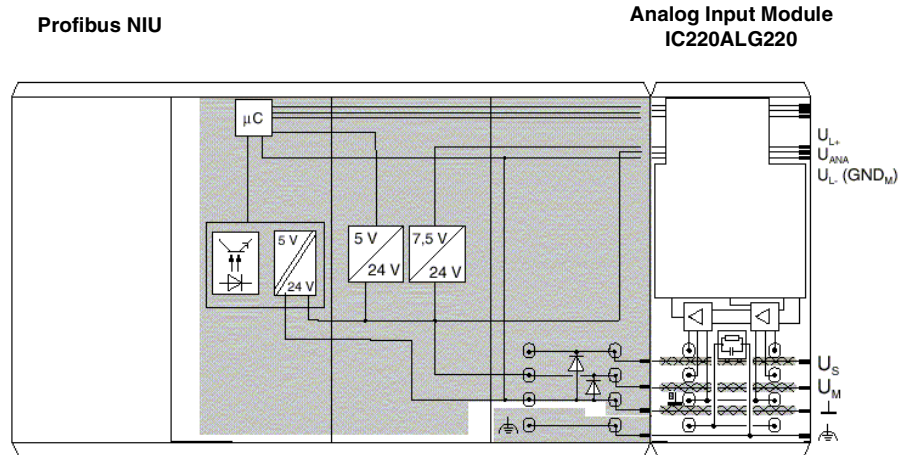

The voltage jumpers hatched **XXXX** in the figure are not used in the analog module. This means that the 24V supply of the NIU (U_M) or the power terminal are electrically isolated from the I/O circuit (measurement amplifier) of the analog module. The I/O circuit of the analog module is supplied by the analog circuit U_{ANA} .

Electrical isolation: Other

Other electrical isolation depends on how the supply voltages are provided. For instance, electrical isolation can be provided by inserting a new 24V supply using a power terminal. During this process the 24V power supply units must not be connected to one another. One method of electrical isolation using a power terminal is illustrated below. Connection between the ground of a supply voltage (U_S or U_M) and functional earth ground should only be made at one point within the station (point A). If a number of grounds are connected to the functional earth ground, the electrical isolation is lost.

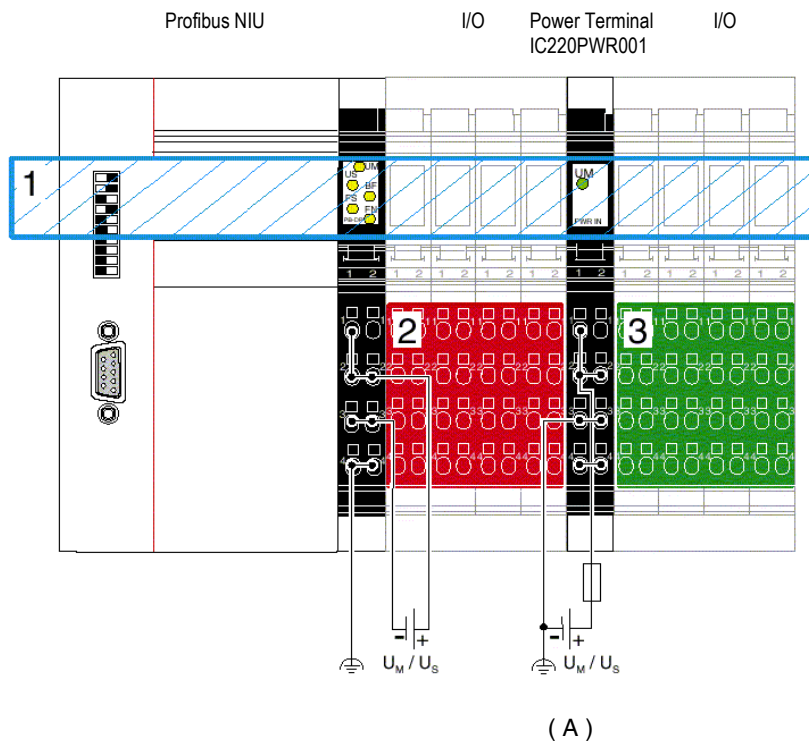

Electrically isolated areas within the station:

- 1 Bus logic of the station
- 2 Isolated I/O
- 3 Isolated I/O

Summary of I/O Module Current Consumptions

The following table provides a summary of the current consumptions each VersaPoint module requires from the various power circuits.

Module Number	Module Description	Current Consumption of:			
		U_L	U_{ANA}	U_S Channel/Module	U_M
<i>Discrete Input Modules</i>					
IC220MDL641	Input 24VDC Positive Logic 2 Points	35mA	-	250mA / 500mA	-
IC220MDL642	Input 24VDC Positive Logic 4 Points	40mA	-	250mA / 1A	-
IC220MDL643	Input 24VDC Positive Logic 8 Points	50mA	-	250mA / 2A	-
IC220MDL644	Input 24VDC Positive Logic 16 Points	60mA	-	250mA / 4A	-
IC220MDL661	Input 24VDC Negative Logic 2 Points	35mA	-	250mA / 500mA	-
<i>Discrete Output Modules</i>					
IC220MDL721	Output 24VDC Positive Logic 2.0A 2 Points	35mA	-	2A / 4A	-
IC220MDL751	Output 24VDC Positive Logic 0.5A 2 Ppoints	33mA	-	500mA / 1A	-
IC220MDL752	Output 24VDC Positive Logic 0.5A 4 Points	40mA	-	500mA / 2A	-
IC220MDL753	Output 24VDC Positive Logic 0.5A 8 Points	60mA	-	500mA / 4A	-
IC220MDL754	Output 24VDC Positive Logic 0.5A 16 Points	90mA	-	500mA / 8A	-
IC220MDL761	Output 24VDC Positive Logic 0.5A 2 Points	32mA	-	500mA / 1A	-
<i>Special Function Modules</i>					
IC220MDD840	High Speed Counter In 1 in/1 out 24VDC	50mA	-	500mA	500mA
<i>Analog Input Modules</i>					
IC220ALG220	Analog In 15 Bit Voltage/Current 2 Channels	88mA	15mA	-	-
IC220ALG620	Analog In 16 Bit RTD 2 Channels	43mA	11mA	-	-
IC220ALG630	Analog In 16 Bit Thermocouple 2 Channels	43mA	11mA	-	-
<i>Analog Output Modules</i>					
IC220ALG320	Analog Out 16 Bit Voltage/Current 1 Channel	35mA	25mA	-	-
IC220ALG321	Analog Out 13 Bit Voltage 1 Channel	35mA	25mA	-	-
IC220ALG322	Analog Out 13 Bit Voltage 2 Channels	35mA	28mA	-	-
<i>Power and Segment Terminals</i>					
IC220PWR001	Power Terminal 24VDC	-	-	-	-
IC220PWR002	Power Terminal Fused 24VDC	-	-	-	-
IC220PWR003	Power Terminal Fused with Diag. 24VDC	25mA	-	-	-
IC220PWR011	Segment Terminal 24VDC	-	-	-	-
IC220PWR012	Segment Terminal Fused 24VDC	-	-	-	-
IC220PWR013	Segment Terminal Fused W/Diag 24vdc	25mA	-	-	-
IC220PWR014	Segment Terminal Elec Fused 24vdc	30mA	-	-	-

VersaPoint Power Consumption Example

When configuring a VersaPoint Station it is important to consider the current requirements of each module in the I/O system. These current requirements are described in the table “Summary of VersaPoint I/O Current Consumptions” shown previously in this chapter, and in the module-specific data sheets. As noted previously:

- If the current load limit is reached at U_S or U_M a new Power Terminal must be inserted
- If the current load limit is reached for U_L or U_{ANA} a new VersaPoint station must be built using a new Network Interface Unit.

The following example shows how the current consumptions of a VersaPoint I/O station can be determined. It also provides insight into the requirement for additional I/O terminals.

Consider an application which requires the following VersaPoint modules:

Catalog Number	Description
IC220MDL721 (Qty 3)	Output, 24VDC Positive Logic, 2.0A, 2 Points
IC220MDL751	Output, 24VDC Positive Logic, 0.5A, 2 Points
IC220MDL752	Output, 24VDC Positive Logic, 0.5A, 4 Points
IC220MDL641 (Qty 2)	Input, 24VDC Positive Logic, 2 Points
IC220MDL644	Input, 24VDC Positive Logic, 8 Points
IC220ALG620	Analog In, 15 Bit RTD, 2 Channel
IC220PWR014	Segment Terminal with Electronic Fuse

Using the table “Summary of VersaPoint I/O Current Consumptions” in this chapter, the following current consumption table can be generated:

Module	No.	Current Consumption of				
		U_L (module)	U_L (total)	U_{ANA}	U_S (module)	U_S (total)
IC220MDL644	1	50mA	50mA		2A	2A
IC220MDL641	2	35mA	70mA		500mA	1A
IC220PWR014	1	30mA	30mA			
IC220MDL752	1	40mA	40mA		2A	2A
IC220MDL751	1	33mA	33mA		1A	1A
IC220MDL721	2	35mA	70mA		4A	8A
IC220MDL721	1	35mA	35mA		1.2A	1.2A
IC220ALG620	1	43mA	43mA	11mA		
Current Load			371mA	11mA		15.2A
Permissible current consumption of the voltage jumper			2A	0.5A		8A

The current requirements for U_L and U_{ANA} are within the supply capability of the Profibus NIU. The current requirement of U_S exceeds the supply capability of the NIU, so additional power terminals must be used. The number of additional power terminals to be used depends on the arrangement of the modules.

As discussed in chapter 4, the recommended sequence of the modules in this example is:

IC220PBI001	IC220MDL721	IC220MDL721	IC220MDL721	IC220MDL752	IC220MDL751	IC220PWR014	IC220MDL643	IC220MDL641	IC220MDL641	IC220ALG620
Us/Um:	4A	1.2A	4A	2A	1A		2A	0.5A	0.5A	
	5.2A		4A	2A	1A		3A			

If this arrangement must be maintained, two additional power terminals are needed:

IC220PBI001	IC220MDL721	IC220MDL721	IC220PWR001	IC220MDL721	IC220MDL752	IC220MDL751	IC220PWR001	IC220PWR014	IC220MDL643	IC220MDL641	IC220MDL641	IC220ALG620
Us/Um:	4A	1.2A		4A	2A	1A			2A	0.5A	0.5A	
	5.2A			7A					3A			

If a system design goal is to use as few terminals as possible, the module sequence must be changed. In this case, only one additional power terminal would be needed:

IC220PBI001	IC220MDL721	IC220MDL721	IC220MDL752	IC220PWR001	IC220MDL721	IC220MDL751	IC220PWR014	IC220MDL643	IC220MDL641	IC220MDL641	IC220ALG620
Us/Um:	4A	1.2A	2A		4A	1A		2A	0.5A	0.5A	
	7.2A				8A						

Please note that while the I/O modules must be rearranged in order to minimize the number of power terminals required, the recommended module sequence is preserved downstream of each power terminal.

Chapter 6

Diagnostics

This chapter describes in detail the indications of the NIU and module LEDs, as well as additional diagnostics features of the VersaPoint station.

- Local diagnostics
 - Profibus NIU
 - VersaPoint modules
 - Local diagnostics example
- Diagnostics available on the Profibus Master
 - Profibus Standard Diagnostics
 - Device Specific Diagnostics

Errors can occur during startup of the VersaPoint station as well as during operation. There are basically two ways of detecting errors. One way errors can be detected is by using local diagnostics with the help of the Profibus NIU LEDs and those on the VersaPoint I/O modules. Alternatively, all types of errors can be sent from the Profibus NIU to the Profibus master via the Profibus diagnostic telegram so that errors can also be diagnosed and corrected using software in the controller.

Local Diagnostics

Diagnostics information is provided by LEDs on the Profibus NIU and the modules attached to it. In general, the I/O Station is operating correctly if all diagnostic LEDs are constantly lit and green. If any LEDs are red or blinking, refer to the diagnostics information below.

LEDS on the Network Interface Unit

The diagnostic LEDs on the NIU indicate the type and location of the error. The NIU is functioning correctly if all of the green LEDs are on. Once errors have been removed, the indicators immediately display the current status.



NIU LED	Color	Meaning
UM	Green	Supply voltage in the main circuit for the NIU, communications power and interfaces present.
US	Green	24 V segment circuit supply present
BF	Red	No communication on Profibus
FS	Red	Defines the function of the FN LED: FS ON: FN indicates the type of error. FS OFF: FN indicates the error number
FN	Red	The number of flashing pulses indicates the type of error or the error number, depending on whether FS is on or not

Possible LED combinations

No.	UM	US	BF	FS	FN	Error	Remedy
1)	○	○	○	○	○	Voltage supply U _M and U _S absent	Check voltage supply U _M and U _S
2)	○	●	○	○	○	Voltage supply U _M absent	Check voltage supply U _M
3)	●	○	○	○	○	Voltage supply U _S absent	Check voltage supply U _S
4)	●	●	○	○	○	No error, everything OK	-
5)	●	●	●	○	○	No communication on Profibus	<ul style="list-style-type: none"> ▪ Correct Profibus address on the NIU ▪ Correct Profibus master settings ▪ Remove Profibus cable fault
6)	●	●	○	●	⊙	Number of pulses on FN indicates the type of error	See the table that follows.
7)	●	●	○	○	⊙	Number of pulses on FN indicates the error number	See the table that follows.

Key: ○ LED OFF ⊙ LED flashing ● LED ON

Determining the Error Cause and Remedy from the NIU LEDs

The type of error and the error number can be determined using the **FS** and **FN** LEDs on the NIU.

- FS ON: the number of flashing pulses on FN indicates the type of error.
- FS OFF: the number of flashing pulses on FN indicates the error number.

This information can be used to determine the type of error from the following table.

Example: FS is on, the FN LED flashes three times simultaneously. The FS LED goes out and the FN LED flashes four times. The error is caused by the use of a module type that is not permitted.

Error Type (FS on, # of FN pulses)	Error No. (FS off, # of FN pulses)	Meaning	Remedy
1	Parameter Error on Profibus (SET_PRM telegram)		
		No distinction made by error numbers	An error has occurred during configuration of the NIU. Check the configuration.
2	Configuration Errors on Profibus (CHK_CFG telegram)		
	1	Not all VersaPoint modules that are present have been configured.	Add extra modules to the configuration.
	2	More VersaPoint modules have been configured than are present.	Remove the extra modules from your configuration or add the missing modules.
	3	The first byte of the special identification format for the VersaPoint module is faulty.	Determine the exact error location, using the device-specific diagnostics in your control system.
	4	Not enough bytes of the special identification format for the last VersaPoint module have been configured	Check the identification format.
	5	The sum of the configured process data for inputs and outputs of the VersaPoint station is greater than 184 bytes.	Determine the exact error location using the device-specific diagnostics in your control system. Combine several VersaPoint modules in the configuration, so that the process data is compressed (resulting in fewer empty bits).

Error Type (FS on, # of FN pulses)	Error No. (FS off, # of FN pulses)	Meaning	Remedy
2	Configuration Errors on Profibus (CHK_CFG telegram) continued		
	6	The ID code of the configured VersaPoint module does not correspond with the ID code of the module in the station.	Determine the exact error location using the device-specific diagnostics in your control system.
	7	The length code of the configured VersaPoint module does not correspond to the length code of the module in the station.	Determine the exact error location using the device-specific diagnostics in your control system.
	8	The amount of manufacturer-specific data of the special identification format for the -VersaPoint module is faulty. The amount must be 2, 3 or a multiple of 2.	Determine the exact error location using the device-specific diagnostics in your control system.
	9	Not enough output process data has been configured within the identification format for the VersaPoint module.	Determine the exact error location using the device-specific diagnostics in your control system.
	10	Not enough input process data has been configured within the identification format for the VersaPoint module.	Determine the exact error location using the device-specific diagnostics in your control system.

Error Type (FS on, # of FN pulses)	Error No. (FS off, # of FN pulses)	Meaning	Remedy
3	<i>Configuration Errors in the VersaPoint Station</i>		
	1	The VersaPoint module is not enabled for operation on the NIU.	Determine the exact error location using the device-specific diagnostics in your control system. Remove the module from the station.
	2	The length code of the VersaPoint module corresponds to a length of 0 bytes.	Determine the exact error location using the device-specific diagnostics in your control system. Check the module and, if necessary, remove it from your configuration.
	3	The length code of the VersaPoint module corresponds to a length of more than 16 bytes.	Determine the exact error location using the device-specific diagnostics in your control system. Remove the module from the station.
	4	Invalid module type present in the station.	Determine the exact error location using the device-specific diagnostics in your control system. Remove the module from the station.
	5	The sum of the process data for the local bus is greater than 250 bytes.	Check the amount of process data and reduce the number of modules in the station.
	6	There are more than 63 VersaPoint modules connected.	Check whether more than 63 VersaPoint are present in the station and reduce the number of modules.
	7	The sum of the process data for the Profibus inputs and outputs is greater than 184 bytes.	Remove the modules from the station.

Error Type (FS on, # of FN pulses)	Error No. (FS off, # of FN pulses)	Meaning	Remedy
4	Errors Within the Station		
	1	An error has occurred during data transmission between the VersaPoint modules (data IN).	Determine the exact error location locally using the LEDs or the device-specific diagnostics in your control system. Check the connection between the devices indicated.
	2	An error has occurred during data transmission between the VersaPoint modules (data OUT).	Determine the exact error location locally the LEDs on the I/O modules, or the device-specific diagnostics in your control system. Check the connection between the device indicated.
	3	An error has occurred during data transmission between the VersaPoint modules.	The exact error location can be detected locally using the flashing LEDs on the I/O modules. Check the connection preceding the indicated devices.
	4	The VersaPoint module is not ready.	Determine the exact error location using the device-specific diagnostics in your control system. Check the indicated devices.
	5	The replaced VersaPoint module does not correspond to the length code or ID code.	A new VersaPoint module does not correspond to the NIU configuration. Determine the exact error location using the device-specific diagnostics in your control system. Remove the module from the station.
	6	An additional VersaPoint module has been detected in the station.	Check the configuration of the station. If the configuration is correct, switch off the current supply for a short period, so that the new configuration is accepted.

Error Type (FS on, # of FN pulses)	Error No. (FS off, # of FN pulses)	Meaning	Remedy
5	<i>Module Errors</i>		
	1	An error has occurred in your I/O circuit (e.g., short-circuit or overload at the actuator).	The station and the VersaPoint module where the I/O error has occurred can be located using the Profibus address and the device number. The error location can also be detected at the flashing LED of the VersaPoint module, or using the device-specific diagnostics in your control system. Using the module data sheet, check which error this error message can trigger. Remove the error from your I/O devices.

Power and Segment Terminal LEDs

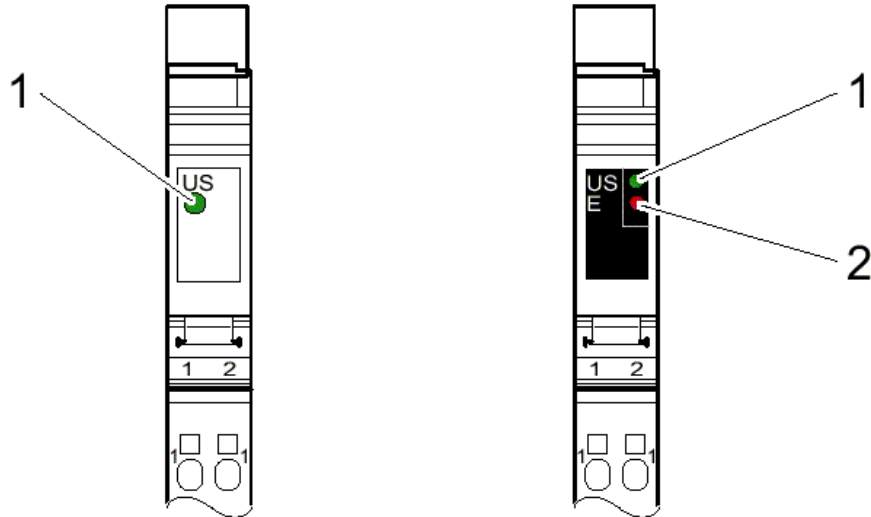

On Power and Segment Terminals with fusing, the green LED indicates that the main or segment voltage is present. In the case of fused terminals (illustration right above), the green LED indicates the main voltage is present at the line side of the fuse. If the red LED is also on, there is no voltage on the load side of the fuse.

Power Terminal LEDs

US (1)	Green LED	Supply voltage in the main circuit
	ON:	Supply voltage present in the main circuit
	OFF:	Supply voltage not present in the main circuit
E (2)	Red LED	On fused modules: fuse status
	ON:	Fuse not present or blown
	OFF:	Fuse OK

Segment Terminal LEDs

US (1)	Green LED	Supply voltage in segment circuit
	ON:	Supply voltage present in segment circuit
	OFF:	Supply voltage not present in segment circuit
E (2)	Red LED	On fused modules: fuse status
	ON:	Fuse not present or blown
	OFF:	Fuse OK

I/O Module LEDs

I/O modules have both diagnostic (1) and status (2) LEDs. All input/output module LEDs are electrically located in the logic area.



Diagnostics LEDs on I/O Modules

The diagnostic indicators (red/green) indicate the status of the modules. A module is operating normally if its diagnostic LED (D) is on and green. If an error is detected, the LEDs immediately display the current status.

D (1)	Green LED	Diagnostics
	ON:	Station is active
	Flashing:	
	0.5 Hz: (slow)	Communications power present, backplane not active
	2 Hz: (medium)	Communications power present, backplane active, I/O error
	4 Hz: (fast)	Communications power present Backplane communications has failed with the module or between the module and the preceding module.
	OFF:	Communications power not present, backplane not active

Status LEDs on I/O Modules

The status indicators (yellow) display the status of the relevant inputs/outputs.

1, 2, 3, 4 (2)	Yellow LED	Status of the input/output
	ON:	Associated input/output ON
	OFF:	Associated input/output OFF

Local Diagnostics Example

The following example provides an indication of how the module LEDs of a VersaPoint station will react in the presence of different types of errors. Two specific errors are shown, an I/O error and a backplane error.

Example Station for Error Identification



Modules used in the example station:

- | | | | |
|---|-------------|---|-------------|
| 1 | IC220PBI001 | 4 | IC220MDL751 |
| 2 | IC200MDL753 | 5 | IC220MDL643 |
| 3 | IC220MDL751 | 6 | IC220MDL641 |

In this illustration, the power terminals are not numbered because they do not include diagnostics and therefore report no data to the NIU. If modules including diagnostics had been selected these modules would report data to the NIU and would be numbered.

The example below shows error states. Either errors have been detected on module 5 or module 4 has broken down. The illustration below shows the behavior of the diagnostic indicators on the adjacent modules.

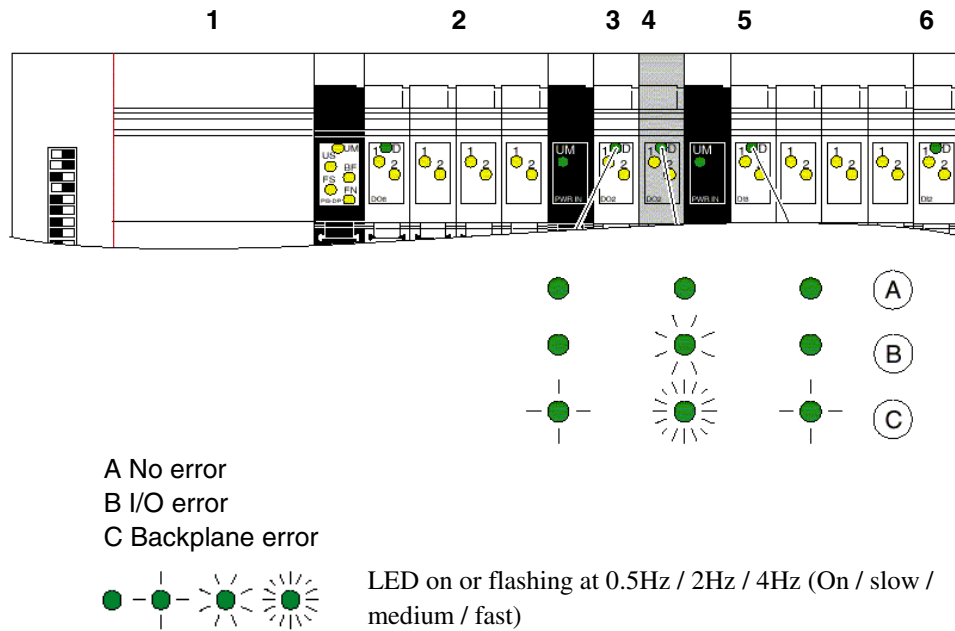

I/O Error

Error:	Short circuit on module 4 (IC220MDL751)
Effect:	
Control system:	Error message to the control system (I/O error)
NIU:	Indicators remain unchanged
Module 4:	Green D LED flashes at 2Hz
Other modules:	Remain unchanged

Backplane Error

Error:	Incoming bus after module 2 and before module 4 has been interrupted
Effect:	
Control system:	Error can be located by the control system
Bus module:	Red LD LED (Local bus Disabled) on
Module 4:	Green D LED flashes at 4Hz (bus error)
Other modules:	Green D LEDs on all other modules flash at 0.5Hz

Diagnostics on the Profibus Master

The error information sent in the diagnostic telegram from the Network Interface Unit to the Profibus master can be displayed using the control system's specific diagnostic tools.

These are "standard diagnostics" and "device-specific diagnostics". The meaning of the data reported in this telegram is given in this section.

Profibus Standard Diagnostics

<i>Byte</i>	<i>Meaning</i>
0	Station status 1
1	Station status 2
2	Station status 3
3	Profibus master address
4	00H manufacturer identification high byte
5	FOH manufacturer identification low byte

Detailed Explanation for Station Status 1 to 3

Stations status 1 to 3 indicates the state of a DP slave.

Structure of station status 1 (byte 0)

Bit	Value	Meaning, Cause	Remedy
0	1	The DP slave is not addressed by the DP master	Is the correct Profibus address set on the DP slave? Is the bus connector connected? Is there voltage to the DP slave? Is the RS-485 repeater set correctly? Has the DP slave been reset?
1	1	The DP slave is not ready for data exchange	Wait, because the DP slave is starting up
2	1	The configuration data sent from the DP master to the DP slave does not correspond to the configuration of the DP slave.	Has the correct station type or the correct DP slave configuration been entered in the configuration software?
3	1	An external diagnostic is present (group diagnostic indicator)	Evaluate the identification-specific diagnostics, the module status and/or the channel-specific diagnostics. Once all errors have been removed, bit 3 is reset. The bit is reset when a new diagnostic message is present in the bytes of the above diagnostics.
4	1	The required function is not supported by the DP slave.	Check configuration
5	1	The DP master cannot interpret the reply of the DP slave	Check bus configuration
6	1	The DP slave type does not correspond with the software configuration	Is the correct station type specified in the configuration software?
7	1	The DP slave has been parameterized by another DP master (not by the DP master that currently has access to the DP slave)	Bit always has the value 1, if, for example, you access the DP slave with the PG or another DP master. The Profibus address of the DP master that parameterized the DP slave is located in the diagnostic byte "master Profibus address".

Structure of station status 2 (byte 1)

Bit	Value	Meaning
0	1	The DP slave must be parameterized again.
1	1	A diagnostic error message has been generated. The DP slave will not operate until the error has been removed (static diagnostic message).
2	1	The bit always has the value 1 if the DP slave with this Profibus address is present.
3	1	Response monitoring is activated for this DP slave.
4	1	The DP slave has received the "FREEZE" control command. This bit is only updated if you change another diagnostic message too.
5	1	The DP slave has received the "SYNC" control command.
6	0	Bit always has the value 0.
7	1	The DP slave is deactivated, i.e., removed from the current process

Structure of station status 3 (byte 2)

Bit	Value	Meaning
0 to 6	0	Always 0.
7	1	There are more error messages than the DP slave can save. The DP master cannot save all diagnostic messages sent from the DP slave in its diagnostic buffer (channel-specific diagnostics).

Profibus – Device-Specific Diagnostics

Byte	Meaning	Explanation
6	0A H header byte	Number of device-specific diagnostic bytes
7	00 H	diagnostic type Diagnostics version
8	Firmware revision	This contains the firmware version in ASCII code. Example: 0x45 corresponds to revision "E".
9	Error type	For information about error type, see "Determining the Error Cause and Remedy" earlier in this chapter.
10	Error number	For information about error number, see "Determining the Error Cause and Remedy" earlier in this chapter.
11	Device number of the VersaPoint module before the error location	This byte contains the logical number of the VersaPoint module in the station in which an error has occurred: the first module is the module immediately to the right of the NIU. Passive devices such as power terminals without diagnostics do not count as devices
12	Device number of the VersaPoint module after the error location	This byte contains the logical number of the VersaPoint module in the station (see #11 above)
13	VersaPoint module ID code	The ID code of the VersaPoint module is used for identification and is marked on the housing and printed in the module data sheet.
14	VersaPoint module length code	The length code is used for identification and for automatic setting of the data width. This is also printed in the module data sheet.
15	Reserved	

Chapter 7

Configuration

This section describes the configuration options of the VersaPoint Profibus NIU.

- Configuration of the NIU
 - Powerup Autoconfiguration
 - NIU DIP Switches
- Configuration of the Profibus Master
- Example Configuration

Configuration of the NIU

In order for a Profibus NIU to communicate on the Profibus Network, its baud rate, station address and I/O modules must be configured. This configuration is accomplished with a combination of autoconfiguration by the NIU and user-set DIP switches.

Powerup Autoconfiguration

The NIU's baud rate and I/O module map are automatically set when the NIU powers up.

On powerup the Profibus NIU identifies the baud rate setting of the Profibus master and automatically adjusts to match. The NIU can communicate at network speeds of 9.6kbps to 12Mbps.

The NIU also identifies the modules attached to it during powerup. If modules are added or removed (not recommended with station power applied) the change will not be reflected in the NIU's configuration until a station power cycle is executed – it will be reflected by the NIU's diagnostics LED's (see Chapter 6). It is important to note that once this configuration change is made, the Profibus master configuration must also be changed. Failure to do so will result in loss of communications.

NIU DIP Switches

The 10-position DIP switch on the NIU module is used to set the Profibus address and to specify the error response of the NIU.

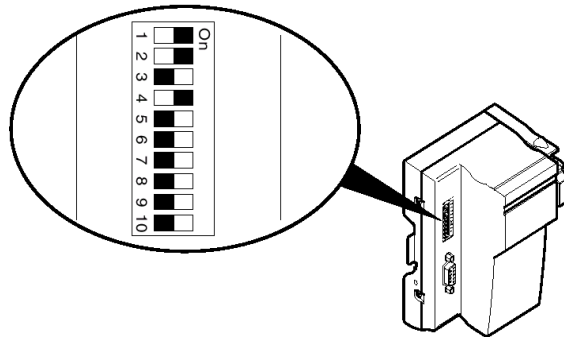

Switches	Meaning
1 to 7	<p>PROFIBUS Address in binary format (= 0 to 127 in decimal format)</p> <p>Switch 1 defines the least significant bit (2^0) and switch 7 defines the most significant bit (2^6).</p>
8	<p>Behavior if a data error occurs in the station (local bus error):</p> <p>ON = data transmission is stopped after a number of attempts. OFF = the station constantly attempts to start data transmission.</p> <p>If DIP switch 8 is in the ON position, a POWER DOWN/POWER UP must be executed on the NIU so that it will restart. There is no automatic restart after the error has been removed.</p>
9 to 10	Reserved, both switches must be in the OFF position.

Configuration of the Profibus Master

Profibus-DP is normally a single master system. This master is typically a communications card installed in a Programmable Logic Controller, industrial PC, or other controller (Drive, Computer Numerical Control, etc.). In each case these communications cards require configuration information for the attached Profibus Slaves to be input. This configuration is typically accomplished using a configuration tool specifically designed for the Profibus master. Given this variability, specific instructions for the configuration of the Profibus Master cannot be given here – Please consult the information available with your Profibus Master. (An example of configuring the VersaPoint Profibus NIU with the Profibus master on the GE Fanuc Series 90-30 PLC is given later in this chapter).

Regardless of their origin, the point of commonality between standard Profibus network configuration tools is the requirement for a GSD file. Every Profibus slave device certified by the Profibus Trade Organization is required to define a GSD file (electronic device data sheet) and this file must be included in the Profibus master configuration for each Profibus slave device.

The GSD file is a simple text file filled with keywords and values that together define the specific characteristics, features, and limitations of the slave device. For the NIU, the GSD file also lists the Profibus configuration identifiers for all currently-supported I/O modules. The GSD file also includes the text strings to properly decode the diagnostic information provided by the NIU.

As new I/O modules are released or new features are added, the GSD file may be updated. A printout of the initial version of the GSD file for the VersaPoint Profibus Network Interface Unit is included in appendix D. It is included only for reference; an electronic version of the GSD file is included on a diskette with each NIU. In addition, the latest GSD file is always available for download from the GSD Library located on the website of the Profibus Trade Organization at www.profibus.com.

The content of the VersaPoint Profibus NIU GSD file is summarized in the table below. This information is limited to data in the area of the VersaPoint I/O modules and does not include information on VersaPoint error messages – please refer to appendix D for this information.

<i>Module Number</i>	<i>Type</i>	<i>Data Length</i>	<i>Special In Byte</i>	<i>Special Out Byte</i>	<i>ID Code dec/hex</i>	<i>Length dec/hex</i>
<i>Discrete Input Modules</i>						
IC220MDL641	Special In	2 bits	00	00	190/BE	194/C2
IC220MDL642	Special In	4 bits	00	00	190/BE	65/41
IC220MDL643	Special In	1 byte	00	00	190/BE	129/81
IC220MDL644	Special In	2 bytes	01	00	190/BE	01/01
IC220MDL661	Special In	2 bits	00	00	190/BE	
IC220MDL220	Special In	2 bits	00	00	190/BE	194/C2
<i>Discrete Output Modules</i>						
IC220MDL721	Special Out	2 bits	00	00	189/BD	194/C2
IC220MDL751	Special Out	2 bits	00	00	189/BD	194/C2
IC220MDL752	Special Out	4 bits	00	00	189/BD	65/41
IC220MDL753	Special Out	1 byte	00	00	189/BD	129/81
IC220MDL754	Special Out	2 bytes	01	00	189/BD	01/01
IC220MDL761	Special Out	2 bits	00	00	189/BD	194/C2
IC220MDL930	Special Out	2 bits	00	00	189/BD	194/C2
<i>Discrete Mixed I/O Modules</i>						
IC220MDD840	Special I/O	4 bytes	C1	C1	191/BF	02/02
IC220MDD841	Special I/O	4 bytes	C1	C1	191/BF	02/02
IC220MDD842	Special I/O	4 bytes	C1	C1	191/BF	02/02
IC220MDD850	Special I/O	4 bits	00	00	190/BF	65/41
<i>Analog Input Modules</i>						
IC220ALG220	Special I/O	4 bytes	41	41	127/7F	02/02
IC220ALG620	Special I/O	4 bytes	41	41	127/7F	02/02
IC220ALG630	Special I/O	4 bytes	41	41	127/7F	02/02
<i>Analog Output Modules</i>						
IC220ALG320	Special Out	2 bytes	00	40	125/7D	01/01
IC220ALG321	Special Out	2 bytes	00	40	125/7D	01/01
IC220ALG322	Special I/O	4 bytes	41	41	91/5B	02/02
<i>Motor Starters</i>						
IC220STR001	Special I/O	1 byte	00	00	191/BF	129/81
IC220STR002	Special I/O	1 byte	00	00	191/BF	129/81
IC220STR003	Special I/O	1 byte	00	00	191/BF	129/81
<i>Power and Segment Terminals</i>						
IC220PWR001	N/A	N/A	N/A	N/A	N/A	N/A
IC220PWR002	N/A	N/A	N/A	N/A	N/A	N/A
IC220PWR003	Special In	2 bits	00	00	190/BE	194/C2
IC220PWR011	N/A	N/A	N/A	N/A	N/A	N/A
IC220PWR012	N/A	N/A	N/A	N/A	N/A	N/A
IC220PWR013	Special In	2 bits	00	00	190/BE	194/C2
IC220PWR014	Special In	2 bits	00	00	190/BE	194/C2

Example Configuration

The following example provides an overview of the steps required to configure a VersaPoint Profibus NIU with the Profibus Master in the GE Fanuc Series 90-30 PLC. The example assumes a basic knowledge of 90-30 configuration in GE Fanuc's VersaPro Software and focuses on the specifics of the Profibus integration.

Example Hardware

The Profibus Master in this example is GE Fanuc Series 90-30 PLC with a Profibus Master Communications Card.

<i>Catalog Number</i>	<i>Description</i>
IC693CPU350 (or higher)	Series 90-30 CPU
HE693PBM101 (rev E or higher)	Profibus Master Communications Card

A VersaPoint I/O system consisting of the following modules will be used in this example.

<i>Catalog Number</i>	<i>Description</i>
IC220PBI001	Profibus-DP Network Interface Unit
IC220MDL721 (Qty 2)	Output, 24VDC Positive Logic, 2.0A, 2 Points
IC220MDL752	Output, 24VDC Positive Logic, 0.5A, 4 Points
IC220MDL641 (Qty 2)	Input, 24VDC Positive Logic, 2 Points
IC220MDL642	Input, 24VDC Positive Logic, 4 Points
IC220PWR001	Power Terminal, 24VDC
IC220ALG321	Analog Out, 16 Bit Voltage, 1 Channel
IC220ALG220	Analog In, 15 Bit Voltage/Current, 2 Channel

NIU Configuration

For this example the VersaPoint I/O station will be configured for Profibus address 11. This is accomplished using the first seven DIP switches on the NIU, as illustrated in the following figure.

Switch	Definition	Example Setting	Example Value
1	2^0	On	1
2	2^1	On	2
3	2^2	Off	0
4	2^3	On	8
5	2^4	Off	0
6	2^5	Off	0
7	2^6	Off	0
Ex. Bus Address (Sum Switch Values) =			11
8	Error Handling Auto-Retry On/Off	Off	Auto-Retry Transmission On
9	Reserved		
10			

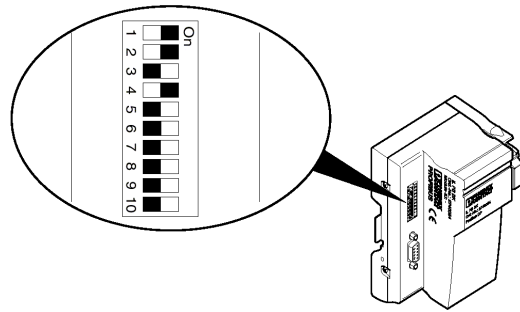

DIP switch 8 selects how the NIU reacts in the event of a communication failure. DIP switches 9 and 10 are reserved and should be in the Off position.

Profibus Master Configuration

Once the Profibus Master Card is inserted in the PLC Configuration a detailed view of the module's configuration parameters may be accessed by zooming into the module. These configuration parameters are divided into 4 tabs as shown in the figure below.

Parameters	Values
Bus Address:	1
Status Reference Type:	%I00065
Status Length:	64
Baud Rate:	1.5M
Min. Slave Interval (0.1ms):	2
Target Rotation Time (t_bits):	18768
Sync/Freeze Control Area	%Q00001
Sync/Freeze Control Area Length	32
Diag Data Slave Addr Area	%AQ0001
Diag Data Slave Addr Area Length	1
Diagnostic Flag Area	%I00001
Diagnostic Flag Area Length	64
Module Revision Area	%AI0001
Module Revision Area Length	1
Diag Data Area	%AI0002
Diag Data Area Length	8
Slot Time (0 Implies use default)	300
Quiet Time (0 Implies use default)	0
Set Time (0 Implies use default)	1
Gap Factor (0 Implies use default)	10
Retry Limit (0 Implies use default)	1
Min T sdr (0 Implies use default)	11
Max T sdr (0 Implies use default)	150
Resp. Monitoring (0 to Disable) (10ms)	30

Profibus Master Module - PTO Certified

Settings Tab

The parameters in the settings tab can be modified to change settings for the Profibus Master Module. The following table provides a description of the parameters in this tab.

<i>Parameter</i>	<i>Description</i>
Bus Address	Assigns the address for this Profibus-DP master module. Default value is 1. Valid addresses are 1 to 125.
Status Reference Type	Location of Status Bits in PLC memory.
Status Length	Number of Status Bits. Currently, the status bit length is fixed at 64 bits.
Baud Rate	Baud Rate of data transmissions on the Profibus network. Valid baud rates range between 9.6K and 12M-bits. Choose a baud rate that matches the other devices on the network.
Min. Slave Interval (.1ms)	Smallest period of time between two successive poll cycles of a particular slave. The slave interval is set in .1ms units and has a valid range of 1-65535. The value for this field should be set to the maximum of all configured slaves. If a .GSD file is imported where the slave value is larger than the configured value, the current value for this parameter will be set to the value in the .GSD file.
Target Rotation Time (t_bits)	Target cycle time in which all slaves will be polled by this master. The target rotation time is set in t_bits and has a valid range of 1-65535. The value for this parameter will be automatically calculated as slave entries are added and/or the Baud Rate is changed. Users may directly edit this parameter or use the default calculated based on baud rate and slave configuration.
Sync/Freeze Control Area	Reference Area for Sync/Freeze data.
Sync/Freeze Control Area Length	32 bits. Not editable.
Diag Data Slave Addr Area	Reference Area for address of desired Slave with requested Diagnosis Data.
Diag Data Slave Addr Area Length	1 word. Not editable.
Diagnostic Flag Area	Reference area for Profibus Diagnosis flags.
Diagnostic Flag Area Length	64 bits. Not editable.

<i>Parameter</i>	<i>Description</i>
Module Revision Area	Reference Area for Module Version
Module Revision Area Length	1 word. Not editable.
Diag Data Area	Reference area for address of diagnosis data
Diag Data Area Length	Dependent on slave data. (From 1 to 122).
Slot Time (0 implies use default)	Profibus Slot Time in bit times. Default is automatically adjusted for a single Master DP bus at the Baud Rate setting. Entering a 0 will also cause default value to be used.
Quiet Time (0 implies use default)	Profibus Quiet time in bit times. Default is automatically adjusted for a single Master DP bus at the Baud Rate setting. Entering a 0 will also cause default value to be used.
Set Time (0 implies use default)	Profibus Set Time in bit times. Default is automatically adjusted for a single Master DP bus at the Baud Rate setting. Entering a 0 will also cause default value to be used.
Gap Factor (0 implies use default)	Profibus Gap Factor (1 – 100). Default is automatically adjusted for a single Master DP bus at the Baud Rate setting. Entering a 0 will also cause default value to be used.
Retry Limit (0 implies use default)	Max Number of message retries. Default is automatically adjusted for a single Master DP bus at the Baud Rate setting. Entering a 0 will also cause default value to be used.
Min Tsdr (0 implies use default)	Profibus Min Tsdr (station delay time) in bit times. Default is automatically adjusted for a single Master DP bus at the Baud Rate setting. Entering a 0 will also cause default value to be used.
Max Tsdr (0 implies use default)	Profibus Max Tsdr (station delay time) in bit times. Default is automatically adjusted for a single Master DP bus at the Baud Rate setting. Entering a 0 will also cause default value to be used.
Resp. Monitoring	Network Response Monitoring Time. Set in 10ms units if enabled.

In general the default parameter settings are acceptable. For VersaPoint I/O drops, exceptions are as follows:

- The **Baud Rate** setting is user-definable. VersaPoint I/O drops will automatically adjust.
- The **Diagnostic Data Area Length** must be at least 8 words to accommodate the VersaPoint Diagnostics message
- Set the **Resp. Monitoring** parameter to 30 to enable Network Monitoring.

Slave Information Tab

Information in this tab defines the characteristics of the slave devices participating in network communications. The Profibus Master Module may be configured to communicate with up to 64 different slave devices. Slave device configuration information is imported from a .GSD file.

Area	GSD File	Bus Address	Sync/Freez	Ident High	Ident Low	Grp Mas	Xtra Parm Len	Xtra Parm Dat
1	C:\WINN	11	Yes/Yes	0	F0	0	0	
2		0	No/No	0	0	0	0	
3		0	No/No	0	0	0	0	
4		0	No/No	0	0	0	0	
5		0	No/No	0	0	0	0	
6		0	No/No	0	0	0	0	
7		0	No/No	0	0	0	0	
8		0	No/No	0	0	0	0	

The following table provides a description of the parameters in the Slave Information Tab.

Parameter	Description
GSD File	The name of the Profibus standard GSD file. The .GSD file is used to automatically import all configuration information about a particular slave. To import a .GSD file, <ol style="list-style-type: none"> 1. Double click the field. A browser window will open. Or, type the file name of the GSD file, and press the Enter key. The GSD Filename Selection dialog box will appear. 2. Select the folder and GSD file you want to import. Click the Open button to complete file selection and start the import process. 3. A series of messages boxes will appear during the .GSD file import. Click OK to continue the import process. Click Cancel to abort the .GSD file import. 4. At this point, you must assign a bus address to the slave entry. To assign the address, edit the Bus Addr column of the corresponding row. Now, configure the offset values.
Bus Address	Assigns the address for this Profibus-DP slave module(s) that are being mapped to this Master. Default value is 0. Valid addresses are 1 to 125.
Sync/Freeze	This is a non-editable field that indicates whether the module is operating in either Freeze Control and/or Sync modes.
Ident High	The high byte Ident Number of the DP-Slave device as assigned by the Profibus Trade Organization. This value is displayed as a hexadecimal number. It is updated automatically if importing a valid GSD file.
Ident Low	The low byte Ident Number of the DP-Slave device as assigned by the Profibus Trade Organization. This value is displayed as a hexadecimal number. It is updated automatically if importing a valid GSD file.
Group Mask	Bit Mask defining group control for Freeze and Sync functions. Each bit identifies a particular group. Group control is enabled if bit 7 in the Flags parameters is set to 1.
Xtra Parm Len	Length of manufacturer-specific extra parameter data. This value is updated automatically if importing a valid GSD file. This field may be directly edited. Value range is 0 to 25. The default value is 0.
Xtra Parm Data	Actual extra parameter data bytes as required by specific slave manufacturer. This value may only be set by importing a GSD file. The default value is 0.
Use WD	Set 1 to indicate that the module is Watchdog Control activated, and 0 if not.

The majority of the information on this tab is imported from the .GSD file. User input is required in the following areas:

- The **GSD File** is shipped on a disk with the VersaPoint Profibus NIU. The file is also available on the GE Fanuc Website, www.gefanuc.com.
- The **Bus Address** of the VersaPoint I/O station in this example is 11.

Data Area Tab

Parameters in this tab are used to map Profibus-DP network data to PLC memory. The order in which the data is configured must be identical to that of the DP-Slave. If configuration mismatches exist, no data will be exchanged with that particular slave. This information may be imported from a .GSD file for non-modular stations.

Area	Slave	Module	Type	Length	Type	Data Length	Input Offset	Output Offset	Special In Byte	Special Out Byte	Mfg 1	2
1	11	1	Spec Out	Byte		0	%I00001	%Q00033	0	0	BD	C2
2	11	2	Spec Out	Byte		0	%I00001	%Q00041	0	0	BD	C2
3	11	3	Spec Out	Byte		0	%I00001	%Q00049	0	0	BD	41
4	11	4	Spec In	Byte		0	%I00129	%Q00001	0	0	BE	C2
5	11	5	Spec In	Byte		0	%I00137	%Q00001	0	0	BE	C2
6	11	6	Spec In	Byte		0	%I00145	%Q00001	0	0	BE	41
7	11	7	Spec Out	Byte		0	%I00001	%AQ0002	0	40	7D	1
8	11	8	Spec I/O	Byte		0	%AI0010	%AQ0003	41	41	7F	2
9	0	1	Empty	Byte		0	%I00001	%Q00001	0	0	0	0
10	0	1	Empty	Byte		0	%I00001	%Q00001	0	0	0	0
11	0	1	Empty	Byte		0	%I00001	%Q00001	0	0	0	0
12	0	1	Empty	Byte		0	%I00001	%Q00001	0	0	0	0
13	0	1	Empty	Byte		0	%I00001	%Q00001	0	0	0	0

The following table provides a description of the parameters in the Data Area Tab.

Parameter	Description
Area	Memory area being defined within the PLC. The Profibus-DP master currently supports 64 unique data areas.
Slave Address	Bus address of the particular slave for which you are mapping data. This value must match a corresponding Bus Address in the Slave Settings tab. (Determined by switch setting on slave module.)
Module #	Particular module ID which is being configured for the given slave address. The number of modules used must be identical to the slave configuration for proper data exchange to occur. This number does not necessarily correspond to the physical module.
Type	Data Type of module being defined. Valid types include Input, Output, I/O (both input and output), Special Input, Special Output, Special I/O, and Empty. The default value is Empty.
Length Type	Specifies whether data is Byte or Word data. Default is Byte.
Data Length	Length of data. This value is expressed in units according to the Length Type field. If the Type field is set to I/O, this value is both the length of the input and output data. Range is 0-16. A value of 0 implies that this area is not defined. This field is not used if Type is set to Special Input, Special Output or Special I/O.
Input Offset	Memory location in PLC where input data will be mapped. This field must be set if the Type value is Input, Special Input, I/O, or Special I/O. The Input Offset is set to the next highest available %I memory location when the type and length is configured for the data area entry.
Output Offset	Memory location in PLC where output data will be mapped. This field must be set if the Type value is Output, Special Output, I/O, or Special I/O. The Output Offset is set to the next highest available %Q memory location when the type and length is configured for the data area entry.
Consistency	Consistency Option Flag. Possible choices are: "Byte/Word" and "Entire Length". This field is not used if Type is set to Special Input, Special Output or Special I/O.
Special In Byte	Data Byte used for Types Special Input and Special I/O. This byte represents a special input identifier as defined by a particular slave. The valid range is 0 to FF(hex).
Special Out Byte	Data Byte used for Types Special Output and Special I/O. This byte represents a special output identifier as defined by a particular slave. The valid range is 0 to FF(hex).
Mfg 1 to 15	These are single byte parameters that are unique to the HE693PBM101. Each of these bytes can be configured to contain a value in the range of 0 to FF(hex). For more information about these parameters, you can obtain a Profibus Specification from the Profibus website at http://www.profibus.com

It is important to note the following points regarding setting the parameters of the Data Area Tab.

- The Profibus NIU and Power/Segment Terminals without diagnostics should not be considered on this tab. The **Module Number** column only includes I/O modules and Power/Segment Terminals with Diagnostics.
- Information for the **Special In Byte, Special Out Byte, Mfg 1, and Mfg 2** parameters can be extracted from the .GSD summary table shown previously in this chapter. In this table "ID Code" equates to **Mfg 1**, and "Length" equates to **Mfg 2**.

This section summarizes the standard data for a VersaPoint Profibus I/O system. Please refer to the module-specific data sheets for additional information.

- Network Specifications
- I/O Station Information
- Ambient conditions
- Mechanical Demands
- Noise Immunity Test
- Electrical Specifications
- Cables
- I/O Modules
- Air and Creepage Distances
- Test Voltages

The data is valid for the preferred mounting position (vertical).

I/O Station Information

System Information	
Number of devices per station	63, maximum
Sum of all I/O data per station	184 bytes, maximum
PROFIBUS-DP Interface	Copper cable (RS-485), connected via D sub shield connector; supply electrically isolated, shielding directly connected with functional earth ground.
Maximum NIU current for supplying the I/O module logic	2A at U_L
Maximum additional current for supplying the analog terminals	0.5A at U_{ANA}
Maximum current consumption of the I/O modules	See chapter 5 and the module datasheets
<p>Observe the logic current consumption of each device when configuring a VersaPoint station! The logic current consumption is indicated in chapter 5 and in each module data sheet. The current consumption can differ depending on the individual module. The permissible number of devices that can be connected depends on the specific station structure.</p>	
Maximum current carrying capacity of the voltage jumpers U_{ANA}	0.5A
Maximum current carrying capacity of the voltage jumpers U_M , U_S (total current)	8A
<p>Observe the current consumption of every device on the individual voltage jumpers when configuring a VersaPoint station! The logic current consumption is given in chapter 5 and in each module data sheet. The current consumption can differ depending on the individual module. If the maximum current carrying capacity of a voltage jumper (8A) is reached, a new power terminal must be used.</p>	

Ambient Conditions

Ambient Conditions	
This table provides standard data for the VersaPoint product family. Please refer to the module data sheets for additional information.	
Regulations	Developed according to VDE 0160, UL 508
Ambient temperature Ambient temperature (operation) Ambient temperature (storage/transport)	-25°C to +55°C (-13°F to +131°F) -25°C to +85°C (-13°F to +185°F)
Operating Humidity	75% on average; 85% occasionally; (no condensation) Ranging from -25°C to +55°C (-13°F to +131°F) appropriate measures against increased humidity (> 85%) must be taken.
Storage Humidity	75% on average; 85% occasionally; (no condensation)
Degree of protection according to DIN 40050, IEC 60529	IP20
Degree of protection according to DIN 57106-1	Class 3
Air and creepage distances	According to IEC 60644/ IEC 60664A/ DIN VDE 0110: 1989-01 and DIN VDE 0160: 1988-05
Degree of pollution according to EN 50178	2; Condensation not permissible in operation.
Surge voltage class	II (low-level signal) III (power level)
Gases that endanger the functions (according to DIN 40046-36, DIN 40046-37)	
Sulphur dioxide (SO ₂)	Concentration 10 ± 0.3 ppm Ambient conditions - Temperature: 25°C (± 2°C) - Humidity: 75% (± 5%) - Test duration: 10 days
Hydrogen sulfide (H ₂ S)	Concentration 1 ± 0.3 ppm Ambient conditions - Temperature: 25°C (± 2°C) - Humidity: 75% (± 5%) - Test duration: 4 days

Mechanical Demands

Mechanical Demands	
Vibration test Sinusoidal vibrations according to IEC 60068-2-6	2g load, 2 hours for each space direction (Low-level signal) 2g load, 2 hours for each space direction (Power level)
Shock test according to IEC 60068-2-27	25g load for 11ms, half sinusoidal wave, three shocks in each space direction and orientation.

Noise Immunity Test

Noise Immunity Test	
Please refer to the module data sheets for additional information.	
<i>In Accordance with EN 50082-2</i>	
Electrostatic Discharge (ESD)	EN 61000-4-2 / IEC 61000-4-2 Criteria B, 4kV contact discharge, 8kV air discharge
Electromagnetic Fields	ENV50140 / ENV50204 Criteria A, Field Strength: 10V/m
Bursts	EN 61000-4-4 / IEC 61000-4-4 Criteria A, All Interfaces:2kV
Conducted Interference	ENV 50141, Criteria A, Test voltage 10V
<i>In Accordance with EN 50082-2</i>	
Noise Emission of the Housing	EN 5011, Class A

Electrical Specifications

7.5V Supply of the Bus Logic (UL)	
Nominal voltage	7.5V (converted from external 24VDC)
Ripple	± 5%
Load current	2A, maximum
Connection	Voltage jumpers on the sides
Remark	Voltage is produced in the NIU by a DC/DC converter from the 24V supply voltage. UL is not electrically isolated from the 24V NIU voltage. UL is not electrically isolated from I/O voltages UM and US . Communications power UL is electronically short-circuit protected.

Supply of Terminals for Digital Signals (UM , US) in the 24V Range	
Nominal voltage	24VDC
Tolerance	- 15% / + 20%
Ripple	± 5%
Permissible voltage range	19.2VDC to 30.0VDC, ripple included
Load current	8A, maximum
Connection	Voltage jumpers on the sides of the module housing.
Remarks	Segment circuit US: All digital outputs and initiator supplies without individual short-circuit protection are connected to the segment circuit US. Main circuit UM: Initiator supplies with individual short-circuit protection are connected to the main circuit UM.

Supply of Terminals for Analog Signals (UANA)	
Nominal voltage	24VDC
Tolerance	- 15% / + 20%
Ripple	± 5%
Permissible voltage range	19.2VDC to 30.0VDC, ripple included
Load current	500mA, maximum
Connection	Voltage jumpers on the sides
Remarks	Isolation of the 24V input voltage by means of a diode. Smoothing through π -filter; corner frequency 9.8 kHz and attenuation of 40 dB/decade. UANA is not electrically isolated from the 24V bus module supply and the 7.5V communications power.

Voltage Dips and Interrupts of the I/O Supply	
Intensity PS1	Interruption time < 1 ms
Time interval between voltage dips	< 1 s
Behavior	Evaluation criterion 1 A < 1 ms supply voltage dip is not registered by the bus.
Intensity PS2	Interruption time < 10 ms
Time interval between voltage dips	< 1 s
Behavior	Evaluation criterion 3: Bus disconnection; all outputs of the system are reset.

Cables

Connection Type/Cable Diameter	
Connection type of cables	Spring-clamp terminals
Cable diameter low level signals (typical)	0.2mm ² up to 1.5mm ² (24 to 16 AWG)
Cable diameter low level signals (connection of equalizing conductors for thermocouples to the IC220ALG630 module)	0.13mm ² up to 1.5mm ² (26 to 16 AWG)
Cable diameter power level (Power terminal, motor connection, brake connection)	0.2mm ² up to 2.5mm ² (24 to 14 AWG) (Flexible and inflexible cables)
Cable diameter power level (Manual mode)	0.14mm ² up to 1.5mm ² (26 to 16 AWG) (Flexible and inflexible cables)

I/O Modules

Parameters of the I/O Modules		
Parameter	Minimum value	Maximum value
Digital I/O modules		
Input/output voltage	18.2VDC	253VAC
Input/output current	0.1mA	5A
Analog I/O modules		
Input/output voltage	0V	30V
Input/output current	0A	20mA

Air and Creepage Distances

<i>Air and Creepage Distances (According to EN 50178, VDE 0109, VDE 0110)</i>			
<i>Isolating Distance</i>	<i>Air Distance</i>	<i>Creepage Distance</i>	<i>Rated Withstand Voltage</i>
<i>Technology for 24V range</i>			
Incoming bus / bus logic	0.3mm	0.3mm	0.5kV
Outgoing bus / bus logic	0.3mm	0.3mm	0.5kV
Incoming bus / outgoing bus	0.3mm	0.3mm	0.5kV
Bus logic / I/O devices	0.3mm	0.3mm	0.5kV
<i>Technology for range up to 250VDC</i>			
Bus logic / I/O devices	3.1mm	1.1mm	4kV
<i>Technology for 230VAC range single-phase (up to 253VAC)</i>			
Bus logic / I/O devices	3.1mm	1.1mm	4kV
<i>Relay outputs</i>			
Main contact / N/O contact	See module-specific data sheet.		
Relay contact / bus logic	See module-specific data sheet.		

Test Voltages

Test Voltages	
Isolating distance	Test voltage
<i>Technology for 24V range (up to 60VDC)</i>	
5 V supply incoming network cable / 5 V supply outgoing network cable	500VAC, 50Hz, 1 min.
5 V supply incoming network cable / 7.5 V communications power, 24V NIU supply	500VAC, 50Hz, 1 min.
5 V supply incoming network cable / 24V main supply, 24V segment supply	500VAC, 50Hz, 1 min.
5 V supply incoming network cable / Functional earth ground	500VAC, 50Hz, 1 min.
5 V supply outgoing network cable / 7.5 V communications power, 24V NIU supply	500VAC, 50Hz, 1 min.
5 V supply outgoing network cable / 24V main supply, 24V segment supply	500VAC, 50Hz, 1 min.
5 V supply outgoing network cable / Functional earth ground	500VAC, 50Hz, 1 min.
7.5 V communications power, 24V NIU supply Functional / earth ground	500VAC, 50Hz, 1 min.
7.5 V communications power, 24V NIU supply / 24V main supply, 24V segment supply	500VAC, 50Hz, 1 min.
24V main supply, 24V segment supply Functional earth ground	500VAC, 50Hz, 1 min.
<i>Technology for range up to 250VDC</i>	
Bus logic / I/O devices	2500VAC, 50Hz, 1 min.
<i>Technology for 230VAC range single-phase (up to 253VAC)</i>	
Bus logic / I/O devices	2500VAC, 50Hz, 1 min.
<i>Relay outputs</i>	
Main contact / N/O contact	1000VAC, 50Hz, 1 min.
Relay contact / bus logic	2500VAC, 50Hz, 1 min.

A

Appendix
B

Glossary

This section provides reference definitions for many of the terms used elsewhere in this manual.

1-wire termination Wire termination method for I/O modules with one termination connection per point. This conductor transfers the signal. I/O module and sensor or actuator must have the same potential.

2-wire termination Wire termination method for I/O modules with two termination connections per point. One conductor transfers the signal and the other the shared potential.

3-wire termination Wire termination method for I/O modules with three termination connections per point. One conductor transfers the signal, one the shared potential, and the third one another shared potential (for instance, shield or earth ground).

4-wire termination Wire termination method for I/O modules with four termination connections per point. One conductor transfers the signal, one the shared potential, and the third and fourth are intended for shield and ground connection.

Actuator An actuator is a device that can influence the behavior of a process and thereby cause a change in the process variables. Actuators are, for example, lamps, switches, etc.

Address The address defines a certain memory location. Data can be written to this location or read when the memory location is accessed.

Analog input An analog input is an input for receiving analog signals.

Analog output An analog output is an output that makes analog signals available.

Connector The connector is snapped onto the electronics base of the VersaPoint module.

Connector coding/ keying With VersaPoint you can prevent the mismatching of connectors by encoding/ keying the base and the connector.

Cycle time The cycle time is the time the system needs to read all data from the connected devices and to write data to all connected devices.

Diagnostic LEDs Diagnostic LEDs provide information on the status of the station.

Electrical isolation Electrical isolation means that the circuits of an electrical device are galvanically separated from each other.

End clamp In a VersaPoint station, the end clamps are placed on the mounting rail on the left-side of the bus interface unit module and after the last module to prevent the module from sliding side ways.

End plate The end plate terminates a VersaPoint station. It has no electrical function. It protects the station against ESD pulses and the user against dangerous contact voltage. The end plate is supplied together with the bus terminal and does not need to be ordered separately.

FE functional earth ground

Full duplex Simultaneous sending and receiving of data.

Functional earth ground A low impedance path between electrical circuits and earth for non-safety purposes such as noise immunity improvement.

Host system A control or computer system.

In process data Data which is transmitted from a device to an application program is IN process data for this application program.

Input Connection point of a circuit or a device where a signal to be processed, amplified, stored or linked with other signals can be connected .

Input address area The input address area is an area in which the devices store their data for the control system.

Input data Input data is data that is transmitted from a device to an application program.

I/O circuit The I/O circuit (Us+, Us-) begins at the NIU and is carried through all subsequent modules until the next power terminal. It supplies all modules that do not need to be isolated from the I/O voltage.

I/O module I/O modules connect to the sensors and actuators.

Logic circuit All connected modules are supplied through the logic circuit with communications power This circuit starts at the NIU and is carried through all VersaPoint modules.

Main circuit The main circuit supplies the VersaPoint station with the main power (UM). The main circuit starts at the NIU or power terminal and is led to the next power terminal.

Master The master is a central device which controls the bus access. All other devices operate as slaves.

Network A network is a communications link that connects devices together. The link operates under a protocol understood by all devices.

Out process data Data which an application program sends to a device is OUT process data for this application program.

Output address area The output address is an area in which the control system stores data which is to be transmitted to the devices.

Potential routing The potentials are routed over an electrical contact in a VersaPoint station that is automatically established when the terminals are properly installed on the mounting rail.

Power-level terminal Power-level terminals are used to switch single-phase or multi-phase power actuators (e.g., motors or lighting).

Power terminal The power terminal is a supply terminal. It supplies the main voltage to the station-internal voltage jumper. In addition to the main voltage, the segment voltage may be supplied or tapped off from the main voltage. Several power terminals can be used in a VersaPoint station. It realizes the electrical isolation between the different current circuits and permits areas with different voltages within the station (e.g., 24VDC and 230VAC).

Protocol A protocol is a set of conventions. It defines data formats and control procedures for communication between devices and processes.

Segment circuit The segment circuit or auxiliary circuit supplies the VersaPoint station modules with the segment voltage (US). The segment circuit starts at theNIU or at a supply terminal (power terminal or segment terminal) and is led through all modules to the supply terminal. It is used to create isolated circuits within the station.

Segment terminal The segment terminal is a supply terminal and is used to create a subcircuit (Segment circuit).

Sensor A sensor is a device that records the physical quantities of a process. The sensor determines the process variables.

Supply terminal Supply terminals in a VersaPoint system are power terminals and segment terminals.

Supply voltage A specific value to be given in volts.

Voltage supply All components used to generate and transmit the supply voltage.

Appendix C

Output Module Derating

This section describes how to find:

- Whether there is a derating on an output module at a specific ambient temperature
- The permissible operating temperature range for an output module

Power Loss of the Housing Within the Operating Temperature Range Depending on the Ambient Temperature

An example is calculated using the IC220MDL721 module.

Formula to calculate the power loss of the electronics

$$P_{\text{tot}} = 0.18 \text{ W} + \sum_{n=0}^2 (200 \text{ mW} + I_{L_n}^2 \times 0.1 \Omega)$$

This formula is terminal-specific and is indicated in every data sheet.

With

P_{tot}	Total power loss of the terminal
n	Index of the number of set outputs $n = 0$ to 2
I_{L_n}	Load current of the output n

Example: Both outputs are connected and carry full load. The load currents of the outputs are $I_{L1} = I_{L2} = 2\text{A}$.

Power Loss of the Electronics

Referring to the formula, the electronics of this specific configuration has the following power loss:

$$P_{\text{tot}} = 0.18\text{W} + 2 \times [0.20\text{W} + (2\text{A})^2 \times 0.1\Omega]$$

$$P_{\text{tot}} = 0.18\text{W} + 2 \times 0.6\text{W}$$

$$P_{\text{tot}} = 0.18\text{W} + 1.2\text{W}$$

$$P_{\text{tot}} = 1.38\text{W}$$



Power Loss of the Housing

The value for the power loss of the housing is indicated in the terminal-specific data sheet. The permissible power loss of the housing for the IC220MDL721 module depends on the temperature.

$$P_{\text{HOU}} = 2.4\text{W} \quad -25^{\circ}\text{C} < T_{\text{U}} \leq -5^{\circ}\text{C}$$

$$P_{\text{HOU}} = 2.4\text{W} - [(T_{\text{U}} - (-5^{\circ}\text{C})) / 37.5 \text{ K/W}] \quad -5^{\circ}\text{C} < T_{\text{U}} \leq 55^{\circ}\text{C}$$

With

P_{HOU} Power loss of the housing

T_{U} Ambient temperature

With an ambient temperature of up to -5°C (23°F), you can load both outputs with 2A because $P_{\text{tot}} > P_{\text{HOU}}$.

Permissible Operating Temperature Range

With an increased ambient temperature, you must calculate the permissible operating temperature range for the calculated power loss.

$$\text{Set } P_{\text{tot}} = P_{\text{HOU}} .$$

$$P_{\text{tot}} = 2.4\text{W} - [(T_{\text{U}} + 5^{\circ}\text{C}) / 37.5\text{K/W}]$$

After changing the formula, the maximum permissible ambient temperature is calculated with this load as:

$$T_{\text{U}} = (2.4\text{W} - P_{\text{tot}}) \times 37.5\text{K/W} - 5^{\circ}\text{C}$$

$$P_{\text{tot}} = 1.38\text{W} \text{ (from the calculated power loss of the electronics)}$$

$$T_{\text{U}} = (2.4\text{W} - 1.38\text{W}) \times 37.5\text{K/W} - 5^{\circ}\text{C}$$

$$T_{\text{U}} = 1.02\text{W} \times 37.5\text{K/W} - 5^{\circ}\text{C}$$

$$T_{\text{U}} = 33.25^{\circ}\text{C}$$

With full load on both outputs, you can operate this module up to an ambient temperature of 33°C (91.4°F). If you never operate the outputs simultaneously and if a set output consumes a current of 2A you can operate the module up to:

$$P_{\text{tot}} = 0.18\text{W} + 1 \times [0.20\text{W} + (2\text{A})^2 \times 0.1\Omega]$$

$$P_{\text{tot}} = 0.18\text{W} + 0.60\text{W}$$

$$P_{\text{tot}} = 0.78\text{W}$$

$$T_{\text{U}} = (2.4\text{W} - P_{\text{tot}}) \times 37.5\text{K/W} - 5^{\circ}\text{C}$$

$$P_{\text{tot}} = 0.78 \text{ W (from the calculated power loss of the electronics)}$$

$$T_{\text{U}} = (2.4\text{W} - 0.78\text{W}) \times 37.5\text{K/W} - 5^{\circ}\text{C}$$

$$T_{\text{U}} = 1.62\text{W} \times 37.5\text{K/W} - 5^{\circ}\text{C}$$

$$T_{\text{U}} = 55.75^{\circ}\text{C}$$

$$T_{\text{U}} = 55^{\circ}\text{C} \text{ (maximum permissible ambient temperature)}$$

As the maximum permissible ambient temperature is 55°C (131°F) you can work in the entire permissible temperature range under the above mentioned conditions.

This leads to a simultaneity of 50% at 55°C indicated in the data sheet

This appendix shows the contents of the GSD file for the VersaPoint Profibus Network Interface Unit. It is included only for reference; an electronic version of the GSD file is included on a diskette with each NIU. In addition, the latest GSD file is always available for download from the GSD Library located on the website of the Profibus Trade Organization at www.profibus.com.

```

;*****
; GSD-File for VersaPoint PROFIBUS-DP NETWORK INTERFACE UNIT
; Manufacturer      : GE Fanuc Automation North America
; Article-No.       : IC220PBI001-AA
; Hardware-Release  : 02
; Firmware-Release  : A (41 hex)
; GSD-Revision      : 1.02
; Date              : 10.01.2002
;*****
;***** History *****
; Revision          Change
; 1.00              -initial product release
; 1.01              -correct entry for 2ch analog output module
; 1.02              -new modules added
;
;*****

#Profibus_DP
GSD_REVISION = 2                ; version ID of the GSD file format
Vendor_Name = "GE Fanuc"        ; manufacturer name
Model_Name = "VersaPoint Profibus NIU" ; device name
Revision = "V2.0"               ; device revision
Ident_Number = 0x05B9           ; product ID
Slave_Family = 3                ; device family class
Protocol_Ident = 0              ; protocol ID of the device
Station_Type = 0                ; device type
FMS_supp = 0                    ; no DP/FMS mixed device
Hardware_Release = "V2.0"       ; hardware revision
Software_Release = "A"          ; software revision
Bitmap_Device = "GEF05B9N"      ; device bitmap - normal state
;Bitmap_DIAG = "GEF05B9D"       ; device bitmap - diagnostic state

9.6_supp = 1                    ; supported baudrates
19.2_supp = 1
93.75_supp = 1
187.5_supp = 1
500_supp = 1
1.5M_supp = 1
3M_supp = 1
6M_supp = 1
12M_supp = 1

```

D

```
MaxTsdr_9.6 = 60 ; device response times
MaxTsdr_19.2 = 60
MaxTsdr_93.75 = 60
MaxTsdr_187.5 = 60
MaxTsdr_500 = 100
MaxTsdr_1.5M = 150
MaxTsdr_3M = 250
MaxTsdr_6M = 550
MaxTsdr_12M = 850

Redundancy = 0 ; no redundancy
Repeater_Ctrl_Sig = 2 ; connector signal CNTR-P: TTL level

,*****
,***** slavespecific data *****
,*****

Freeze_Mode_supp = 1 ; device supports freeze mode
Sync_Mode_supp = 1 ; device supports sync mode
Auto_Baud_supp = 1 ; automatic baud rate recognition
Min_Slave_Intervall = 1 ; min cycle time 0.1ms
User_Prm_Data_Len = 0 ; length of User_Prm_Data
Max_Diag_Data_Len = 16 ; max length of diagnostic data

,*****
,***** modular device *****
,*****

Modular_Station = 1 ; modular device
Max_Module = 64 ; max 64 modules
Max_Input_Len = 184 ; max 184 bytes input data
Max_Output_Len = 184 ; max 184 bytes output data
Max_Data_Len = 184 ; max sum: 184 bytes input and output
data

,***** digital output modules *****

Module="OUT RELAY 3A 1PT" 0x82,0x00,0xBD,0xC2
EndModule
Module="OUT RELAY 3A 4PT" 0x82,0x00,0xBD,0x41
EndModule
Module="OUT 12-253VAC 0.5A 1PT" 0x82,0x00,0xBD,0xC2
EndModule
Module="OUT 24VDC POS 0.5A 2PT" 0x82,0x00,0xBD,0xC2
EndModule
Module="OUT 24VDC POS 2A 2PT" 0x82,0x00,0xBD,0xC2
EndModule
Module="OUT 24VDC NEG 2PT" 0x82,0x00,0xBD,0xC2
EndModule
Module="OUT 24VDC POS 0.5A 4PT" 0x82,0x00,0xBD,0x41
EndModule
Module="OUT 24VDC POS 0.5A 8PT" 0x82,0x00,0xBD,0x81
EndModule
Module="OUT 24VDC POS 2A 8PT" 0x82,0x01,0xBD,0x01
EndModule
Module="OUT 24VDC POS 0.5A 16PT" 0x82,0x01,0xBD,0x01
EndModule
```

```
;***** digital output modules, packed *****

Module="OUT RELAY 3A 1PT (QTY.2) 4 Bit" 0x83,0x00,0xBD,0xC2,0x02
EndModule
Module="OUT RELAY 3A 1PT (QTY.3) 6 Bit" 0x83,0x00,0xBD,0xC2,0x03
EndModule
Module="OUT RELAY 3A 1PT (QTY.4) 8 Bit" 0x83,0x00,0xBD,0xC2,0x04
EndModule
Module="OUT RELAY 3A 4PT (QTY.2) 8 Bit" 0x83,0x00,0xBD,0x41,0x02
EndModule
Module="OUT 24VDC POS 2PT (QTY.2) 4 Bit" 0x83,0x00,0xBD,0xC2,0x02
EndModule
Module="OUT 24VDC POS 2PT (QTY.3) 6 Bit" 0x83,0x00,0xBD,0xC2,0x03
EndModule
Module="OUT 24VDC POS 2PT (QTY.4) 8 Bit" 0x83,0x00,0xBD,0xC2,0x04
EndModule
Module="OUT 24VDC POS 4PT (QTY.2) 8 Bit" 0x83,0x00,0xBD,0x41,0x02
EndModule

;***** digital input modules *****

Module="IN 120VAC 1PT" 0x42,0x00,0xBE,0xC2
EndModule
Module="IN 230VAC 1PT" 0x42,0x00,0xBE,0xC2
EndModule
Module="IN 24VDC POS 2PT" 0x42,0x00,0xBE,0xC2
EndModule
Module="IN 24VDC NEG 2PT" 0x42,0x00,0xBE,0xC2
EndModule
Module="IN 24VDC POS 4PT" 0x42,0x00,0xBE,0x41
EndModule
Module="IN 24VDC POS 8PT" 0x42,0x00,0xBE,0x81
EndModule
Module="IN 24VDC POS 16PT" 0x42,0x01,0xBE,0x01
EndModule

;***** digital input modules, packed *****

Module="IN 24VDC POS 2PT (QTY.2) 4 Bit" 0x43,0x00,0xBE,0xC2,0x02
EndModule
Module="IN 24VDC POS 2PT (QTY.3) 6 Bit" 0x43,0x00,0xBE,0xC2,0x03
EndModule
Module="IN 24VDC POS 2PT (QTY.4) 8 Bit" 0x43,0x00,0xBE,0xC2,0x04
EndModule
Module="IN 24VDC POS 4PT (QTY.2) 8 Bit" 0x43,0x00,0xBE,0x41,0x02
EndModule

;***** analog output modules *****

Module="ALG OUT 16B VOL/CURR 1CH" 0x82,0x40,0x7D,0x01
EndModule
Module="ALG OUT 16B VOLTAGE 1CH" 0x82,0x40,0x7D,0x01
EndModule
Module="ALG OUT 13B VOLTAGE 2CH" 0xC2,0x41,0x41,0x5B,0x02
EndModule
```

D

```
;***** analog input modules *****

Module="ALG IN 15B VOL/CURR 2CH" 0xC2,0x41,0x41,0x7F,0x02
EndModule
Module="ALG IN 15B VOL/CURR 8CH" 0xC2,0x41,0x41,0x5F,0x02
EndModule
Module="ALG IN 16B RTD 2CH" 0xC2,0x41,0x41,0x7F,0x02
EndModule
Module="ALG IN 16B THERMOCOUPLE 2CH" 0xC2,0x41,0x41,0x7F,0x02
EndModule

;***** power-level terminals *****

Module="IN THERMISTOR 1PT" 0x42,0x00,0xBE,0x41
EndModule
Module="MOTOR STR DIRECT 1.5KW/400VAC" 0xC2,0x00,0x00,0xBF,0x81
EndModule
Module="MOTOR STR REVSNG 1.5KW/400VAC" 0xC2,0x00,0x00,0xBF,0x81
EndModule
Module="MOTOR STR DIRECT 3.7KW/400VAC" 0xC2,0x00,0x00,0xBF,0x81
EndModule

;***** special function modules *****

Module="HIGH SPEED CNTR 1IN/1OUT 24VDC " 0xC2,0xC1,0xC1,0xBF,0x02
EndModule
Module="INC ENCDR IN 4IN/4OUT 24VDC" 0xC2,0xC1,0xC1,0xBF,0x02
EndModule
Module="ABS ENCDR IN 4IN/4OUT 24VDC" 0xC2,0xC1,0xC1,0xBF,0x02
EndModule

;***** power- and segment terminals *****

Module="PWR TERM FUSED W/DIAG 24VDC" 0x42,0x00,0xBE,0xC2
EndModule
Module="SEG TERM FUSED W/DIAG 24VDC" 0x42,0x00,0xBE,0xC2
EndModule
Module="SEG TERM ELEC FUSED 24VDC" 0x42,0x00,0xBE,0xC2
EndModule

;*****
;***** device diagnostics *****
;*****

;*****
;***** PROFIBUS standard diagnostics *****
; Byte 0 station state 1
; Byte 1 station state 2
; Byte 2 station state 3
; Byte 3 PROFIBUS master address
; Byte 4 00H (manufacturers ID high Byte)
; Byte 5 00H (manufacturers ID low Byte)
;*****
```

```
*****
***** device specific diagnostics *****
*****
; Byte 6 0AH (Header Byte, number of following byte)
; Byte 7 00H (type of diagnostics)
; Byte 8 firmware revision, ASCII coded
; Byte 9 error type
; Byte 10 error number
; meaning of error type-error number:
; 1: parameterization error PROFIBUS
; 2: configuration error PROFIBUS
; 2-1: less modules configured than connected
; 2-2: more modules configured than connected
; 2-3: 1st byte of special signature format is incorrect
; 2-4: for last module not enough byte of special signature format configured
; 2-5: sum of configured process data > 184 byte
; 2-6: different ID codes for configuration and module
; 2-7: different length codes for configuration and module
; 2-8: number of manufacturer specific data is incorrect
; 2-9: not enough output bytes configured
; 2-10: not enough input bytes configured
; 2-11: configuration of PROFIBUS needs more than 244 bytes
; 3: configuration error local bus station
; 3-1: module not allowed
; 3-2: module length code is zero
; 3-3: module length code > 32 byte
; 3-4: module not allowed
; 3-5: sum of local bus process data too large
; 3-6: more than 64 modules connected
; 3-7: sum of PROFIBUS process data > 184 Byte
; 4: local bus error
; 4-1: local bus error (Data In)
; 4-2: local bus error (Data Out)
; 4-3: error can not be localized
; 4-4: localbus module not ready
; 4-5: new local bus module has an incorrect length- or ID-code
; 4-6: additional local bus module connected
; 5: module error
; 5-1: peripheral fault
; Byte 11 local bus module before fault (or module with peripheral fault)
; Byte 12 local bus module after fault (or module with peripheral fault)
; Byte 13 local bus module ID code
; Byte 14 local bus module length code
; Byte 15 reserved
*****

***** error type *****

Unit_Diag_Area = 16-23
Value(1) = "#1-parameter error PROFIBUS"
Value(2) = "#2-PROFIBUS configuration error"
Value(3) = "#3-local bus configuration error"
Value(4) = "#4-local bus error"
Value(5) = "#5-module error"
Unit_Diag_Area_End
```

D

```
,***** error number *****  
  
Unit_Diag_Area = 24-31  
Value(1) = "Error number: #1"  
Value(2) = "Error number: #2"  
Value(3) = "Error number: #3"  
Value(4) = "Error number: #4"  
Value(5) = "Error number: #5"  
Value(6) = "Error number: #6"  
Value(7) = "Error number: #7"  
Value(8) = "Error number: #8"  
Value(9) = "Error number: #9"  
Value(10) = "Error number: #10"  
Value(11) = "Error number: #11"  
Unit_Diag_Area_End  
  
,***** error location start *****  
  
Unit_Diag_Area = 32-39  
Value(1) = "Module 1"  
Value(2) = "Module 2"  
Value(3) = "Module 3"  
Value(4) = "Module 4"  
Value(5) = "Module 5"  
Value(6) = "Module 6"  
Value(7) = "Module 7"  
Value(8) = "Module 8"  
Value(9) = "Module 9"  
Value(10) = "Module 10"  
Value(11) = "Module 11"  
Value(12) = "Module 12"  
Value(13) = "Module 13"  
Value(14) = "Module 14"  
Value(15) = "Module 15"  
Value(16) = "Module 16"  
Value(17) = "Module 17"  
Value(18) = "Module 18"  
Value(19) = "Module 19"  
Value(20) = "Module 20"  
Value(21) = "Module 21"  
Value(22) = "Module 22"  
Value(23) = "Module 23"  
Value(24) = "Module 24"  
Value(25) = "Module 25"  
Value(26) = "Module 26"  
Value(27) = "Module 27"  
Value(28) = "Module 28"  
Value(29) = "Module 29"  
Value(30) = "Module 30"  
Value(31) = "Module 31"  
Value(32) = "Module 32"  
Value(33) = "Module 33"  
Value(34) = "Module 34"  
Value(35) = "Module 35"  
Value(36) = "Module 36"  
Value(37) = "Module 37"  
Value(38) = "Module 38"  
Value(39) = "Module 39"  
Value(40) = "Module 40"
```

```
Value (41) = "Module 41"  
Value (42) = "Module 42"  
Value (43) = "Module 43"  
Value (44) = "Module 44"  
Value (45) = "Module 45"  
Value (46) = "Module 46"  
Value (47) = "Module 47"  
Value (48) = "Module 48"  
Value (49) = "Module 49"  
Value (50) = "Module 50"  
Value (51) = "Module 51"  
Value (52) = "Module 52"  
Value (53) = "Module 53"  
Value (54) = "Module 54"  
Value (55) = "Module 55"  
Value (56) = "Module 56"  
Value (57) = "Module 57"  
Value (58) = "Module 58"  
Value (59) = "Module 59"  
Value (60) = "Module 60"  
Value (61) = "Module 61"  
Value (62) = "Module 62"  
Value (63) = "Module 63"  
Value (64) = "Module 64"  
Unit_Diag_Area_End  
  
;***** error location end *****  
  
Unit_Diag_Area = 40-47  
Value (1) = "-Module 1"  
Value (2) = "-Module 2"  
Value (3) = "-Module 3"  
Value (4) = "-Module 4"  
Value (5) = "-Module 5"  
Value (6) = "-Module 6"  
Value (7) = "-Module 7"  
Value (8) = "-Module 8"  
Value (9) = "-Module 9"  
Value (10) = "-Module 10"  
Value (11) = "-Module 11"  
Value (12) = "-Module 12"  
Value (13) = "-Module 13"  
Value (14) = "-Module 14"  
Value (15) = "-Module 15"  
Value (16) = "-Module 16"  
Value (17) = "-Module 17"  
Value (18) = "-Module 18"  
Value (19) = "-Module 19"  
Value (20) = "-Module 20"  
Value (21) = "-Module 21"  
Value (22) = "-Module 22"  
Value (23) = "-Module 23"  
Value (24) = "-Module 24"  
Value (25) = "-Module 25"  
Value (26) = "-Module 26"  
Value (27) = "-Module 27"  
Value (28) = "-Module 28"  
Value (29) = "-Module 29"  
Value (30) = "-Module 30"
```

D

```
Value(31) = "-Module 31"
Value(32) = "-Module 32"
Value(33) = "-Module 33"
Value(34) = "-Module 34"
Value(35) = "-Module 35"
Value(36) = "-Module 36"
Value(37) = "-Module 37"
Value(38) = "-Module 38"
Value(39) = "-Module 39"
Value(40) = "-Module 40"
Value(41) = "-Module 41"
Value(42) = "-Module 42"
Value(43) = "-Module 43"
Value(44) = "-Module 44"
Value(45) = "-Module 45"
Value(46) = "-Module 46"
Value(47) = "-Module 47"
Value(48) = "-Module 48"
Value(49) = "-Module 49"
Value(50) = "-Module 50"
Value(51) = "-Module 51"
Value(52) = "-Module 52"
Value(53) = "-Module 53"
Value(54) = "-Module 54"
Value(55) = "-Module 55"
Value(56) = "-Module 56"
Value(57) = "-Module 57"
Value(58) = "-Module 58"
Value(59) = "-Module 59"
Value(60) = "-Module 60"
Value(61) = "-Module 61"
Value(62) = "-Module 62"
Value(63) = "-Module 63"
Value(64) = "-Module 64"
Unit_Diag_Area_End

;***** ID code *****

Unit_Diag_Area = 48-55
Value(189) = "ID code: 189" ; DO
Value(190) = "ID code: 190" ; DI, thermistor, power- and segment
terminals with diagnostics
Value(91) = "ID code: 91" ; AO
Value(125) = "ID code: 125" ; AO
Value(95) = "ID code: 95" ; AI
Value(127) = "ID code: 127" ; AI
Value(191) = "ID code: 191" ; motor starter, special function module
Unit_Diag_Area_End

;***** length code *****

Unit_Diag_Area = 56-63
Value(1) = "Data length: 1 word"
Value(2) = "Data length: 2 words"
Value(65) = "Data length: 4 Bit"
Value(129) = "Data length: 1 Byte"
Value(194) = "Data length: 2 Bit"
Unit_Diag_Area_End
;
```

D

A

Actuators, connecting, 4-19
Air and Creepage Distances, A-1
Ambient conditions, A-1
Analog modules, connecting, 4-22
Analog voltage, 5-2
Autoconfiguration, 7-2

B

Baud rate, 2-4, 7-2

C

Cable connection, 4-10
Cable length, 2-4
Cables, A-1
Catalog numbers, 3-3
Clamp, shielded cable, 4-12
Clamps, 4-2
Color coding, 3-9, 3-11
 connector, 3-13
Configuration, 7-2
 change, 7-2
 example software screens, 7-8
 Profibus master, 7-4
Connector
 color coding, 3-13
 dimensions, 3-15
 part numbers, 3-13
 styles, 3-13
Connectors
 parts of, 3-9
Current consumption, 5-12

D

Derating, C-1
Diagnostics
 LEDs, 2-9
 local, 6-2
 Profibus master, 6-12
DIN rail
 installing and removing modules, 4-8
DIN rail clamps, 4-2
DIP switch, 7-3

DIP switches, 2-8, 4-6

E

Electrical Specifications, A-1
Electronics base, 3-9, 3-10
End clamps, 2-3
End plate, 4-2

F

Fuse replacement, 4-18
Fusing, 4-17

G

Grounding, 4-13
GSD file, 7-4, D-1
 supplied on diskette, 2-5

I

I/O station
 module sequence, 4-3
 modules, 3-2
 parts, 4-2
 power sources, 5-4
 structure, 2-3
 typical, 2-2
IC220ACC313
 end clamps, 2-3
IC220PBI001
 Profibus NIU, 2-4
IC220TBK087, 2-7
Isolation, 4-5, 5-8

K

Keying, 4-7

L

Labeling, 4-24
LEDs
 green or yellow, 3-11
 I/O status, locations, 3-12
 modules, 6-9

Index

NIU, 2-9, 6-2
power and segment terminals, 6-8
Logic voltage, 5-2

M

Mechanical Demands, A-1
Module LEDs, 6-9
Module parts, 3-9
Modules
datasheets for, 1-4
number per station, 1-2
sequence, 4-3

N

Network Specifications, A-1
NIU
DIP switches, 4-6
NIU DIP switches, 2-8
NIU power connector, 2-7
Noise Immunity Test, A-1
Number of modules, 1-2

O

Ordering information, 2-5

P

Part numbers, 3-3
Power connector, 2-7
Power consumption, 5-13
Power sources, 4-4
Power supply, 5-4
Power Terminal LEDs, 6-8
Power Terminal module, 3-7
Profibus connector, 2-6
Profibus NIU
features, 2-4

S

Segment circuits, 5-7
Segment Terminal LEDs, 6-8
Segment Terminal module, 3-8
Segment voltage, 5-2

supplying, 4-17
Sensors, connecting, 4-19
Shield clamp, 4-12
Shielded cable connection, 4-11
Specifications
NIU, 2-10
Status LEDs, 6-9
System overview, 1-1

T

Termination resistor, 2-6

U

Unshielded cable connection, 4-10