

PACSystems™ RX7i IC698PSD300-B

Power Supply

GFK-2315B
June 29, 2005

The RX7i power supplies provide +5 VDC, +12 VDC, and -12 VDC power, and logic level sequencing signals to modules on the RX7i backplane. The high capacity power supply provides up to 300 W total output. This power supply requires forced air cooling, provided by a fan tray mounted on the bottom of the rack.

The power supply module plugs directly into slot 0 of the RX7i main rack.

Protection is provided for overcurrent, overtemperature, and overvoltage fault conditions.

Features

- Operation from 18 to 30 VDC
- Three output voltages
 - +5 VDC output up to 50 amps
 - +12 VDC output up to 10 amps
 - 12 VDC output up to 4 amps
- Slide-in rack mount construction
- Electronic short circuit overcurrent protection
- Overcurrent and overvoltage fault protection

Release Information

Release History

Version	Date
B	Jun 2005
A	Initial release, Feb 2005

Problems Resolved in this Release (B)

Subject	Description
Power supply shutdown due to overtemperature	In previous versions, a power supply shutdown during overtemperature conditions could cause loss of CPU memory. Version B corrects this problem.

Functional Compatibility

The B version is interchangeable with previous versions.

POWER SUPPLY
300W DC

● FIELD OK
● OUTPUT OK
● OVER TEMP

PACSystems™
RX7i

SUPPLY LINE FUSES

WARNING
DO NOT DISCONNECT
WHILE CIRCUIT IS
ALIVE UNLESS AREA IS
KNOWN TO BE
NONHAZARDOUS.

WARNING
EXPLOSION HAZARD - WHEN IN HAZARDOUS
LOCATIONS, TURN OFF POWER BEFORE
REPLACING OR WIRING MODULES.

GFK-2315B

Power Supply Operation

On/Off Switch

The two position On/Off switch, located on the front faceplate, is a logic level switch that enables or disables the output channels only. This switch does not interrupt the DC line input.

Warning

Lethal voltages are present inside the module whenever input power is present.

Indicators

The following LED indicators are provided on the power supply front panel.

<i>LED Name</i>	<i>Color</i>	<i>Function</i>
FIELD OK	green	Turns ON when DC power is applied within its specification range.
OUTPUT OK	green	Turns ON when all three DC outputs channels are operating within their specifications. Turns OFF if any of the three DC output channels has failed.
OVER TEMP	red	Turns On if the critical supply temperature is exceeded or if the airflow sensor detects cessation of air flow.

VMEbus Power Monitor Interface Timing

ACFAIL#

The ACFAIL# signal is pulled down when the power supply inputs are no longer being provided or when the ON/OFF switch is OFF. The ACFAIL# signal is asserted at least 5ms before outputs fall below their specified limits to provide sufficient warning to the system of power failure.

SYSRESET#

The RX7i power supplies do not drive the SYSRESET# signal on the VME backplane. The RX7i CPU module controls the SYSRESET# signal.

Overvoltage Protection

Any output channel that exceeds the nominal output voltage by 15% or more will cause all outputs to latch off. The ON/OFF control switch or the DC input power must be recycled to reset

Replaceable fuses are present on both the positive and negative DC inputs. The power supply uses ATO style 30 Amp fuses.

Overcurrent/Short Circuit Protection

All outputs are protected against overcurrent and short circuit with automatic recovery upon removal of fault.

An electronic current limit is provided on each of the three outputs. An overload on any output will cause the voltage to collapse and may cause the other output voltages to collapse.

Normal operation will resume after removal of the overload. Some component cooling time may be required before normal operation resumes.

Over Temperature Protection

The RX7i power supplies have internal temperature sensing that shuts down the output channels when overheated. The supply will automatically recover once the internal temperature has decreased to operating levels.

The power supply is capable of operating at full capacity (300W) from 0 to 60°C with 70 CFM forced air cooling provided by a fan tray mounted below the system chassis. The power supply can operate at a limited capacity with only convection cooling. See the Temperature Derating Curve below

Airflow Sensor

An airflow sensor is provided to detect a fan failure or air blockage. If the power supply senses a cessation of air flow, it responds by switching off all outputs and turning on the overtemperature LED indicator. The power supply automatically recovers from this condition when the internal temperature has decreased to operating levels.

You can enable or disable the airflow sensor via a jumper located on the outside of the Power Supply. The airflow sensor option is enabled (Jumper present) as the default for each power supply.

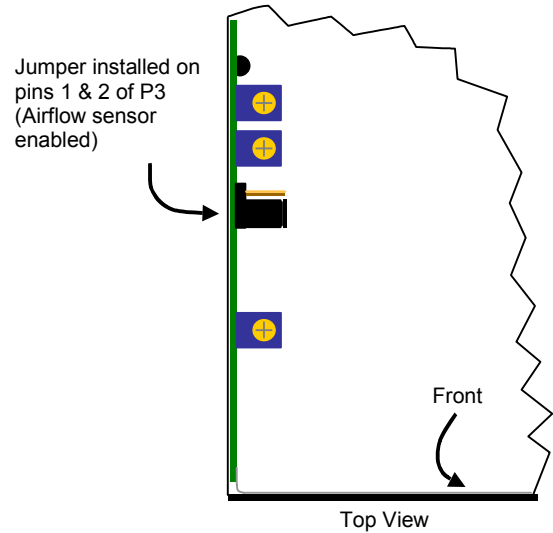

Location of Airflow Sensor Jumper – Top View

Temperature Derating

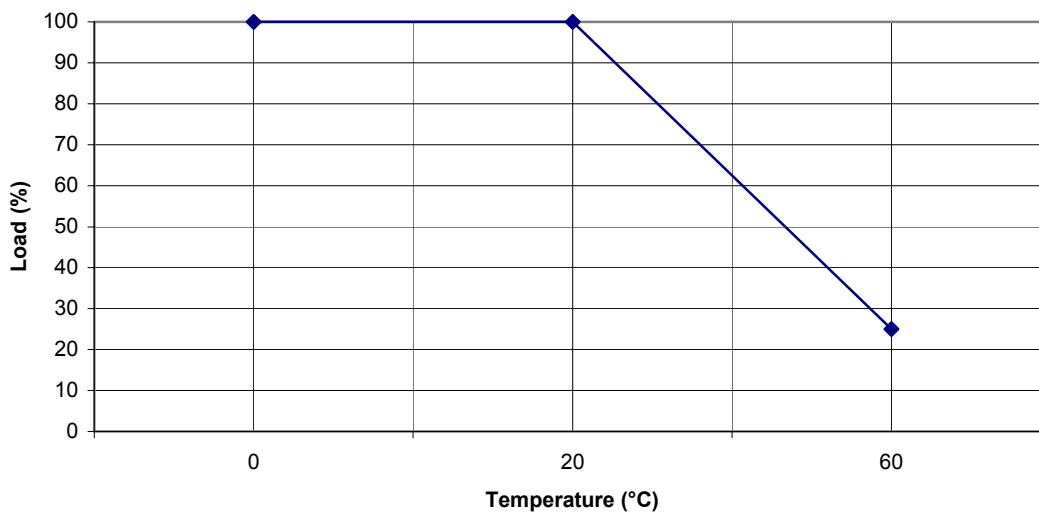

GFK-2315B

Installation

Warning

Do not remove (or insert) modules when the power supply or any externally-connected power sources are on. Hazardous voltages may exist. Personal injury, damage to the module, or unpredictable operation of the device or process being controlled may result.

This Power Supply is a plug-in module that is installed in the leftmost slot of any standard RX7i rack. For additional installation information, refer to *PACSystems RX7i Installation Manual*, GFK-2223.

Power Source and Ground Connections

The input terminals are located on the front faceplate of the power supply. Power input connections should be made with copper AWG #16 (1.3 mm²) wire rated for 75°C (167°F). Each terminal can accept two solid or stranded wires, but the wires into any given terminal should be the same type and size. The terminal can accept a single wire connection up to AWG #12. All wire lengths should be stripped to 0.25" (7mm). **Longer stripping lengths will result in exposed power wires, which is a potential shock hazard.**

For additional noise protection, the input wires may be routed through the supplied choke core as shown on page 5.

The **GND** (ground) terminal on the power supply should be connected to the GND terminal on the rack and to earth using copper AWG #12 (3.3 mm²) wire rated for 75°C (167°F) to ensure adequate grounding. Use of a ring terminal and star washer to ensure ground integrity is recommended.

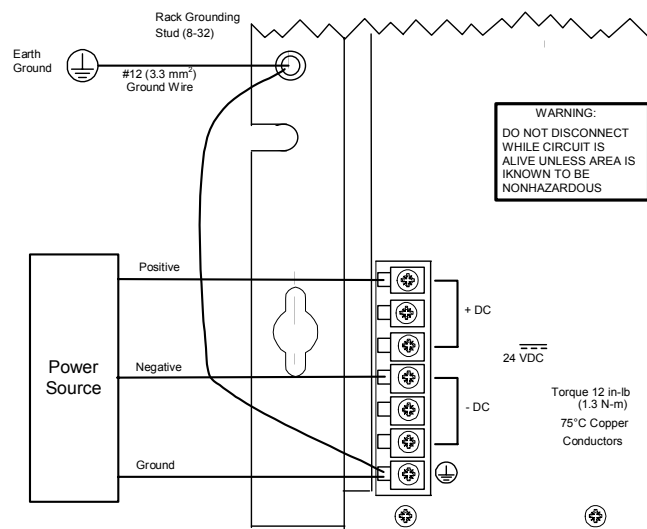

Terminal Board Connections for IC698PSD300

System Noise Protection

The following steps must be taken to reduce the possibility of errors due to electrical noise.

- Make sure that the power supply mounting screws are properly secured.
- Properly ground the system as described in “Power Source and Ground Connections” on page 4.

For additional noise protection, the input wires may be routed through the supplied choke core as shown in the following figure. Wrap each wire once through the core.

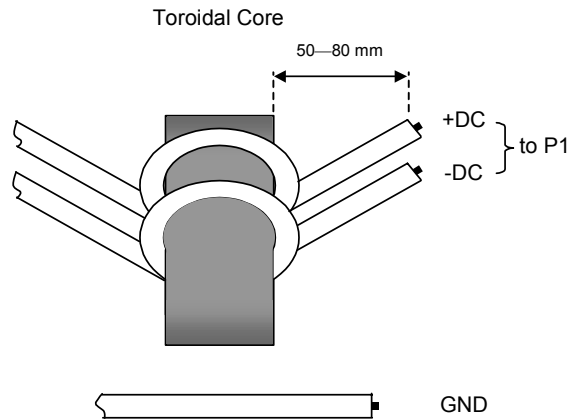

Input Wires Routed Through Supplied Core

Note: Each RX7i module has a noise reduction gasket on the right side of the faceplate that maintains contact with the adjacent module or the rack. (RX7i power supplies have the noise strip on both sides.) Installing modules that do not have this strip makes the rack system more susceptible to electrical noise.

GFK-2315B

Specifications

Nominal Rated Voltage:	24 VDC
Input Voltage Range:	18 to 30 VDC
Input Power:	430 watts (typical), 550 watts (maximum)
Inrush current (cold start, 24 VDC)	100 amps maximum
Output Requirements	
Output Power:	300 watts maximum (total for all 3 outputs)
Output Voltage:	+5 VDC: 4.875 to 5.25 volts, 0 to 50 amps +12 VDC: 11.64 to 12.6 volts, 0 to 10 amps -12 VDC: -12.60 to -11.64 volts, 0 to 4 amps
Isolation , input to all outputs	250 VAC continuous; 1500 VAC for 1 minute
Protective Limits:	
Overvoltage Limit:	+5 VDC Output: 5.7 to 6.7 volts
Overcurrent Limit:	+5 VDC output: 65 A typical
	+12 VDC output: 15 A typical
	-12 VDC output: 6 A typical
Ride-through (time allowed for loss of input power without affecting DC outputs)	15 milliseconds minimum
Holdup Time (time from ACFAIL# system failure signal is activated to when any DC output drops out of specification)	5 milliseconds minimum
Operating Temperature:	0°C to 60°C (32°F to 140°F) Fan tray attachment required for full capacity. See "Ordering Information."

For environmental specifications and compliance to standards (for example, FCC or European Union Directives), refer to Appendix A of the PACSystems RX7i Installation Manual, GFK-2223.

Ordering Information

<i>Description</i>	<i>Catalog Number</i>
RX7i Power Supply: 24 VDC Input, 300watt output	IC698PSD300
120 VAC Input Rack Fan Assembly , Standard	IC697ACC721
240 VAC Input Rack Fan Assembly , Standard	IC697ACC724
24 VDC Input Rack Fan Assembly, Standard	IC697ACC744
120 VAC Input Rack Fan Assembly, Narrow	IC697ACC621
240 VAC Input Rack Fan Assembly, Narrow	IC697ACC624
24 VDC Input Rack Fan Assembly, Narrow	IC697ACC644

Installation in Hazardous Locations

The following statements are required to appear for Class I Div 2 Hazardous Locations.

- EQUIPMENT LABELED WITH REFERENCE TO CLASS I, GROUPS A, B, C, and D, DIV. 2 HAZARDOUS LOCATIONS IS SUITABLE FOR USE IN CLASS I, DIVISION 2, GROUPS A, B, C, D OR NON-HAZARDOUS LOCATIONS ONLY.
- WARNING – EXPLOSION HAZARD – SUBSTITUTION OF COMPONENTS MAY IMPAIR SUITABILITY FOR CLASS I, DIVISION 2.
- WARNING – EXPLOSION HAZARD – DO NOT DISCONNECT EQUIPMENT UNLESS POWER HAS BEEN SWITCHED OFF OR THE AREA IS KNOWN TO BE NON-HAZARDOUS.