

PACSystems™ RX7i

IC698ETM001

Ethernet Interface

GFK-2227B
August 2004

The IC698ETM001 Ethernet Interface module provides high performance Ethernet communications for the RX7i control system. The Ethernet Interface provides TCP/IP communications with other GE Fanuc control systems, CIMPLICITY® software systems, and host computers with software for Ethernet communications to GE Fanuc PLCs. These communications use the GE Fanuc SRTP and Ethernet Global Data (EDG) protocols over a four-layer TCP/IP (Internet) stack. The figure on page 2 shows the RX7i in a basic Ethernet communication system.

Features

- The Ethernet Interface provides:
 - Data exchange using Ethernet Global Data (EGD)
 - TCP/IP communication services using SRTP
 - Full PLC programming and configuration services
 - Comprehensive station management and diagnostic tools
- Extends the connectivity of an RX7i with IEEE 802.3 CSMA/CD 10Mbps and 100Mbps Ethernet LAN ports.
- The Ethernet Interface contains two full-duplex 10BaseT/100BaseT/TX (RJ-45 Connector) ports with an internal network switch providing auto-negotiated network speed, duplex mode, and crossover detection.
- Use of BaseT permits direct connection to BaseT (twisted pair) network hub or repeater without an external transceiver.
- The Ethernet Interface plugs into a single-width slot in an RX7i rack and is configured using the Proficy™ Machine Edition programming software.
- Up to three Ethernet Interface modules can be installed in an RX7i CPU rack.
- Firmware is pre-loaded for easy installation and is maintained indefinitely; firmware is easily upgraded in-system through the RX7i CPU serial port using WinLoader.
- Redundant IP addressing – can be used by Ethernet interfaces in conjunction with Hot Standby CPU Redundancy. This feature allows a single IP address, the Redundant IP Address, to be assigned to a pair of Ethernet modules, which are in two units in a redundant system. The Redundant IP Address is configured in addition to the normal unique IP address of each interface. Only the Ethernet interface in the active unit can use the Redundant IP Address.
- EGD Class 2 functionality (Commands) - acknowledged single command transfers (sometimes referred to as “datagrams”) and Reliable Data Service (RDS) retry mechanism to make sure a command message gets through once and only once.

+

ETHERNET

STATION
MANAGER



+

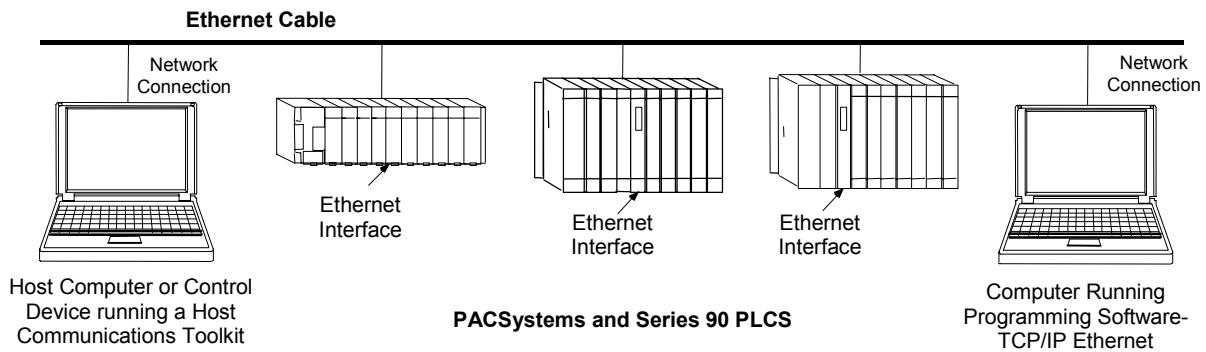

IEEE 802.3 Media

The Ethernet Interface can operate directly on 10BaseT/100BaseTX media via its network ports. These media are described below.

10BaseT: 10BaseT uses a twisted pair cable of up to 100 meters in length between each node and a hub or repeater. Typical hubs or repeaters support 6 to 12 nodes connected in a star wiring topology.

100BaseTX: 100BaseTX also uses a cable of up to 100 meters in length between each node and a hub or repeater. The cable should be data grade Category 5 unshielded twisted pair (UTP) or shielded twisted pair (STP) cable. Two pairs of wire are used, one for transmission, and the other for collision detection and receive. Typical hubs or repeaters support 6 to 12 nodes connected in a star wiring topology.

Physical Description

The Ethernet Interface has the following user-accessible features:

- Default station Media Access Control (MAC) identifier address label (located on the side of the Ethernet board)
- Seven LEDs
- Restart Pushbutton
- Station Mgr (RS-232) Serial Port
- Two 10BaseT/100BaseTX Network Ports

MAC Address Label

Each IC698ETM001 Ethernet module has an assigned MAC address. The MAC address label is located on the side of the Ethernet board. This label is visible only when the module is removed from the rack. The figure on page 3 illustrates the location of the MAC address label.

LEDs

The Ethernet Interface indicators consist of seven LEDs. All are single-color green LEDs controlled by the Ethernet interface.

- Module OK (EOK)
- LAN online (LAN)
- Status (STAT)
- Two speed LEDs (100) (one per port)
- Two activity LEDs (LINK) (one per port)

The **EOK**, **LAN**, and **STAT** LEDs are grouped together and indicate the state and status of the Ethernet interface.

Each Ethernet port has two green LEDs, **LINK** and **100**.

For details of RX7i Ethernet LED operation, see page 4.

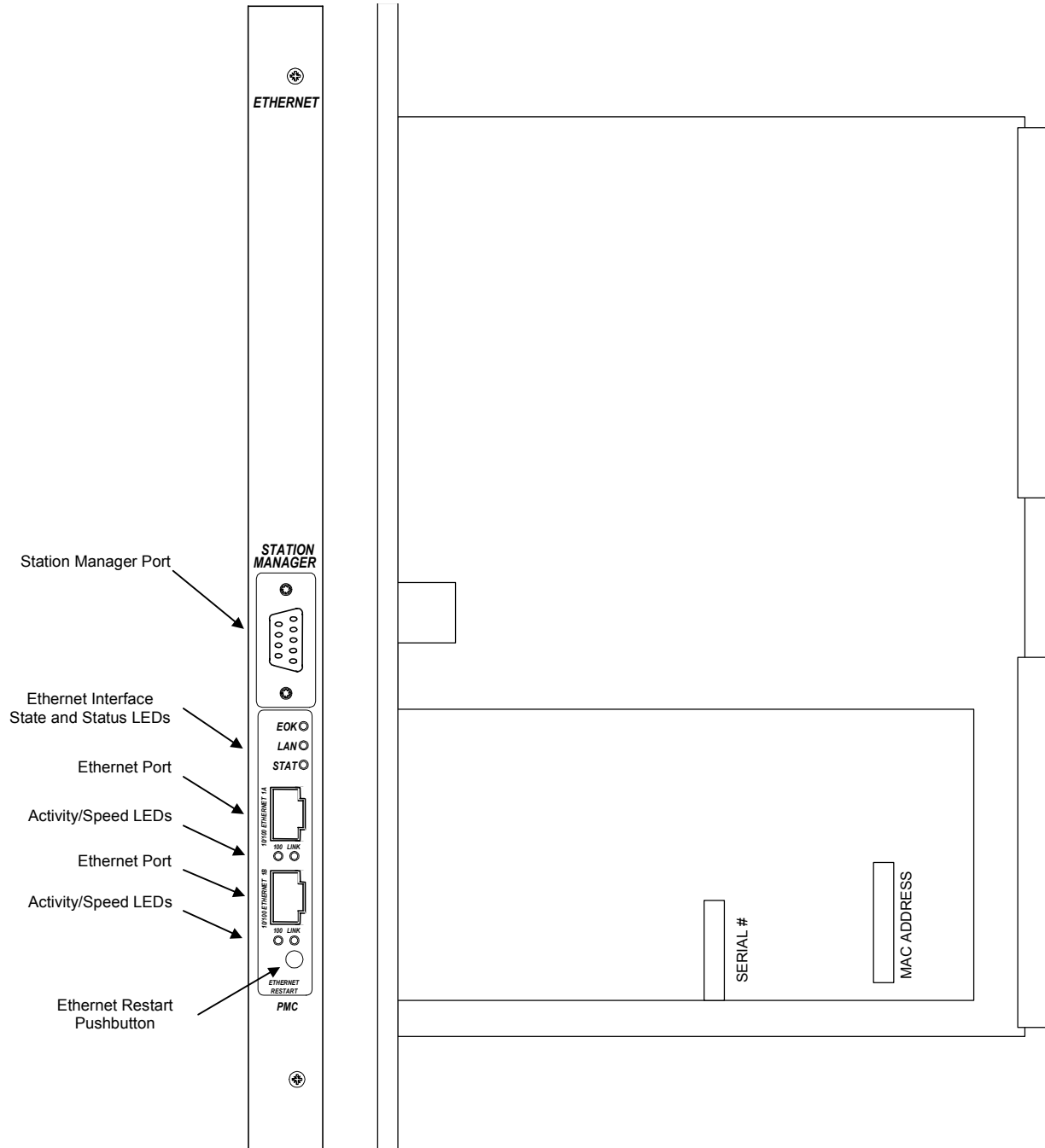

Ethernet Interface Module Features

Ethernet LED Operation

LED State			Ethernet Operating State
On Blinking Off			
 	EOK Fast Blink LAN Off STAT Off		Performing Diagnostics
 	EOK Slow Blink LAN Off STAT Off		Waiting for Ethernet configuration from CPU
 	EOK Slow Blink* LAN On/Traffic/Off STAT Slow Blink* (* EOK and STAT blink in unison)		Waiting for IP Address
 	EOK On LAN On/Traffic/Off STAT On/Off		Operational
 	EOK Blink error code LAN Off STAT Off		Hardware Failure. For blink code definitions, refer to <i>TCP/IP Ethernet Communications for PACSystems, GFK-2224</i>
 	EOK Slow Blink* LAN Slow Blink* STAT Slow Blink* (* All LEDs blink in unison; pattern same for awaiting, performing load)		Software Load

EOK LED Operation

The EOK LED indicates whether the module is able to perform normal operation. This LED is on for normal operation and flashing for all other operations. When a hardware or unrecoverable runtime failure occurs, the EOK LED repeatedly blinks a two-digit error code identifying the failure. For definitions of LED blink codes, refer to the TCP/IP Ethernet Communications for the RX7i User’s Manual, GFK-2224.

LAN LED Operation

The LAN LED indicates access to the Ethernet network. During normal operation and while waiting for an IP address, the LAN LED blinks to indicate network activity. This LED remains on when the Ethernet interface is not actively accessing the network but the network is available, and it is off if network access is not available.

STAT LED Operation

The STAT LED indicates the condition of the Ethernet interface in normal operational mode. If the STAT LED is off, an event has been entered into the exception log and is available for viewing via the Station Manager interface. The STAT LED is on during normal operation when no events are logged.

In the other states, the STAT LED is either off or blinking and helps define the operational state of the module.

Ethernet Port LEDs Operation (100Mb and Link/Activity)

Each of the two Ethernet ports has two green LEDs, **100** and **LINK**. The **100** LED indicates the network data speed (10 or 100 Mb/sec). This LED is illuminated if the network connection is 100 Mbps.

The **LINK** LED indicates the network link status and activity. This LED is illuminated when the link is physically connected and blinks when traffic is detected at the port. Note that traffic at the port does not necessarily mean that traffic is present at the RX7i Ethernet interface, since the traffic may be going between ports of the switch.

Ethernet Restart Pushbutton

This pushbutton is used to manually restart the Ethernet firmware without power cycling the entire control system. It is recessed to prevent accidental operation.

LED Operation during Restart

When the Ethernet firmware is manually restarted by the Ethernet pushbutton in any state, the EOK, LAN and STAT LEDs are briefly turned on in unison as an LED test. The Ethernet port LEDs are not affected by a manual restart of the Ethernet firmware.

The LED test is performed only upon a manual pushbutton restart; there is no LED test when the Station Manager initiates a restart.

RJ-45 Ethernet Network Ports**Caution**

The two ports on the Ethernet module must not be connected, directly or indirectly, to the same device. The hub or switch connections in an Ethernet network must form a tree and not a ring; otherwise duplication of packets and network overload may result.

Note: The module has two RJ-45 connectors but only one IP address.

Each RX7i Ethernet interface contains two eight-conductor RJ-45 shielded twisted pair Ethernet ports, for connection to either a 10BaseT or 100BaseTX IEEE 802.3 network. Either shielded or unshielded twisted pair cable can be attached to a port. Each Ethernet port automatically senses whether it is connected to a 10BaseT or 100BaseTX network, half-duplex or full-duplex. The user does not configure the network type. (The automatic negotiation of speed and/or duplex mode can be overridden by using AUP settings.) Standard twisted pair Ethernet cable is used for connection to other devices. Category 5 cable is required for 100BaseTX operation.

Each network port automatically operates in either normal or crossover mode. This capability allows directly wiring the Ethernet interface to another device without an intervening network hub/switch, and without requiring a special crossover cable. This allows you to connect RX7i Ethernet interfaces in a daisy chain arrangement. Care should be taken when using daisy chaining, since power loss or reset at an Ethernet interface will cause loss of communication to any devices downstream from that Ethernet interface in the daisy chain. Restarting the Ethernet interface (using the Ethernet Restart pushbutton, for example) also disrupts daisy chain communication.

RJ-45 Ethernet Port Pin Assignment

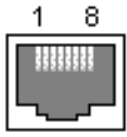
Pin No.	Ethernet 10BaseT 100BaseTX	Pin Position on RJ-45 Connector 
1	Transmit +	
2	Transmit -	
3	Receive +	
4	N/A	
5	N/A	
6	Receive -	
7	N/A	
8	N/A	

Station Manager Port (RS-232)

Operating a local area network entails certain LAN management activities such as network performance measurement, status information, and fault diagnosis.

The Ethernet Interface contains many features to support these activities. Some of these features are accessed via the Station Manager, a portion of the Ethernet Interface operating firmware that responds to user commands. The Station Manager operates locally via an ASCII terminal or terminal emulator connected to the Station Manager (RS-232) serial port, or remotely over the Ethernet LAN. Refer to the *PACSystems RX7i TCP/IP Ethernet Communications Station Manager Manual*, GFK-2225 for complete information on the Station Manager.

Each RX7i Ethernet interface provides a dedicated RS-232 serial port for local Station Manager use. This port has a nine-pin D connector and accepts a standard straight-through nine-pin RS-232 serial cable (such as IC200CBL001). The location of this serial port is shown in the figure on page 3. The Ethernet Interface module does not use this port for firmware upgrades. See "Firmware Upgrades" on page 6 for firmware upgrade details.

Station Manager (RS-232) Port Pin Assignment

Pin No	Signal	Direction	Description
1	DCD	IN	Data Carrier Detect
2	TXD	OUT	Transmit Data
3	RXD	IN	Receive Data
4	DSR	IN	Data Set Ready
5	GND		Signal Ground
6	DTR	OUT	Data Terminal Ready
7	CTS	IN	Clear to Send
8	RTS	OUT	Ready to Send
9	RI	IN	Ring Indicator

Ethernet Global Data (EGD)

Each RX7i CPU supports up to 255 simultaneous Ethernet Global Data (EGD) exchanges. EGD exchanges must be configured in the programming software and stored into the CPU. The EGD configuration can also be loaded from the CPU into the programming software. Both produced and consumed exchanges can be configured. RX7i CPUs support using only part of a consumed EGD exchange, and EGD exchange production and consumption to the broadcast IP address of the local subnet.

The RX7i CPU supports 2msec EGD exchange production and timeout resolution. RX7i EGD exchanges can be configured for a production period of 0, indicating the exchange is to be produced every output scan. These “as fast as possible” exchanges are not produced more often than 2msec. RX7i CPUs support enhanced EGD freshness, providing better EGD timeliness than Series 90-70 CPU products.

Advanced User Parameters

Advanced User Parameters (AUP) are internal operating parameters used by the Ethernet interface. For most applications, the default AUP should *not* be changed.

Caution

The IEEE 802.3 standard strongly discourages the manual configuration of duplex mode for a port (as would be possible using Advanced User Parameters). Before manually configuring duplex mode for a port using AUP, be sure that you know the characteristics of the link partner and are aware of the consequences of your selection. In the words of the IEEE standard: “Connecting incompatible DTE/MAU combinations such as full duplex mode DTE to a half duplex mode MAU, or a full-duplex station (DTE or MAU) to a repeater or other half duplex network, can lead to severe network performance degradation, increased collisions, late collisions, CRC errors, and undetected data corruption.”

Note: If both speed and duplex mode of an Ethernet interface port are forced using AUP, that port will no longer perform automatic cable detection. This means that if the Ethernet interface port is connected to an external switch or hub port, a crossover cable must be used. If the Ethernet interface port is connected to the uplink port on an external switch or hub, or the Ethernet interface port is directly connected to another Ethernet device, a normal (straight-through) cable must be used.

Indirect Firmware Upgrades

All RX7i Ethernet interfaces receive their firmware upgrades indirectly via the CPU. To install a firmware upgrade, connect WinLoader to the CPU serial port and specify the target module by its Rack/Slot location.

Installation

This section describes the physical installation of the Ethernet Interface into the RX7i rack. The installation process is completely described in the *TCP/IP Ethernet Communications for the RX7i User's Manual*, GFK-2224.

1. Read and record the 12-digit hexadecimal MAC Address from the printed label on the Ethernet Interface. Refer to the figure on page 3 for the location of this label.
2. Be sure the *RX7i* rack power is OFF.
3. Slide the Ethernet Interface into the slot for which it is or will be configured.
4. Press the board firmly in place, but do not force the board. Tighten the screws on the top and bottom of the module's faceplate.
5. Connect one or both of the network ports on the Ethernet Interface to the Ethernet network.
6. Power up the rack.

Configuring the Ethernet Interface

Essential network addresses for an Ethernet Interface are set up using the Machine Edition configuration software and stored to the CPU. These addresses must be properly configured before the Ethernet Interface can be used by your application. The configuration process is described in the *TCP/IP Ethernet Communications for the RX7i User's Manual*, GFK-2224.

For initial installation when there is no IP addressing information in the RX7i Ethernet Interface, Machine Edition (or Local Station Manager) is used to assign an IP address to the Ethernet Interface. Once set up, the Ethernet Interface retains the IP addressing information. The IP addressing information can be changed by storing a new configuration to the CPU.

Powering Up the Ethernet Interface

After the Ethernet Interface has been properly configured, turn power OFF to the rack, then turn power back ON.

During Power-Up

The EOK LED on the Ethernet Interface blinks while the Interface performs power-up diagnostic tests and while waiting for configuration data from the CPU.

After Power-Up

The LED indications described below indicate that the Ethernet Interface is ready for use.

- The EOK LED stops blinking and remains ON.
- The LAN LED may be ON, OFF, or BLINKING — depending upon network activity.
- The STAT LED should be ON, indicating no exception conditions.

Corrective Actions

- If the EOK LED is OFF, a hardware fault has occurred in the Ethernet Interface or in the CPU that prevents the Ethernet Interface from operating.
- If the EOK LED is ON, but the STAT LED is OFF, an operational problem has occurred.

Refer to *TCP/IP Ethernet Communications for the PACSystems RX7i*, GFK-2224 for detailed diagnostics information.

Related Publications

PACSystems RX7i CPU Reference Manual, GFK-2222

PACSystems RX7i Installation Manual, GFK-2223

TCP/IP Ethernet Communications for the PACSystems RX7i, GFK-2224

PACSystems RX7i TCP/IP Ethernet Communications Station Manager Manual, GFK-2225

Proficy Machine Edition Logic Developer-PLC Getting Started, GFK-1918

Specifications*

Ethernet processor speed	200 MHz
Module Operating Voltage	+5 VDC, (from power supply)
Module Current Drain	1.5 (+5 VDC) maximum; 1.2 A typical
Module Operating Temperature	0°C to + 60°C (32°F to 140°F)
LEDs	MODULE OK LAN ONLINE STATUS 100, LINK P1 100, LINK P2
LAN	IEEE 802.2 Logical Link Control Class I IEEE 802.3 CSMA/CD Medium Access Control 10/100 Mbps
Number of IP addresses	One
Ethernet Ports	Two, both are 10BaseT / 100BaseTX with auto-sensing. RJ-45 connector, 8-pin female, shielded
Embedded Ethernet Switch	Yes – Allows daisy chaining of Ethernet nodes
Serial Port	Station Mgr Port: RS-232 DCE, 1200 - 115200 bps. D-connector, 9-pin female

* For environmental specifications and compliance to standards (for example, FCC or European Union Directives), refer to Appendix A of the *PACSystems RX7i Installation Manual*, GFK-2223.

Ordering Information

Description	Catalog Number
Ethernet Interface for RX7i	IC698ETM001
[Optional]: Station Manager cable for Ethernet Interface	IC200CBL001