



GE Fanuc Automation

Programmable Control Products

Stepping Motor Cube™ with Pulse and Direction Interface

User's Manual

GFK-2209

July 2002

Warnings, Cautions, and Notes as Used in this Publication

Warning

Warning notices are used in this publication to emphasize that hazardous voltages, currents, temperatures, or other conditions that could cause personal injury exist in this equipment or may be associated with its use.

In situations where inattention could cause either personal injury or damage to equipment, a Warning notice is used.

Caution

Caution notices are used where equipment might be damaged if care is not taken.

Note

Notes merely call attention to information that is especially significant to understanding and operating the equipment.

This document is based on information available at the time of its publication. While efforts have been made to be accurate, the information contained herein does not purport to cover all details or variations in hardware or software, nor to provide for every possible contingency in connection with installation, operation, or maintenance. Features may be described herein which are not present in all hardware and software systems. GE Fanuc Automation assumes no obligation of notice to holders of this document with respect to changes subsequently made.

GE Fanuc Automation makes no representation or warranty, expressed, implied, or statutory with respect to, and assumes no responsibility for the accuracy, completeness, sufficiency, or usefulness of the information contained herein. No warranties of merchantability or fitness for purpose shall apply.

The following are trademarks of GE Fanuc Automation North America, Inc.

Alarm Master	Genius	PROMACRO	Series Six
CIMPLICITY	Helpmate	PowerMotion	Series Three
CIMPLICITY 90-ADS	Logicmaster	PowerTRAC	VersaMax
CIMSTAR	Modelmaster	Series 90	VersaPro
Field Control	Motion Mate	Series Five	VuMaster
GENet	ProLoop	Series One	Workmaster

Content of this Manual

This manual applies to the following Motion products:

IC800MCUB12 __ 0XN

IC800MCUB12 __ 0XE

Related Publications

Additional information about Motion solutions is available at
<http://www.gefanuc.com/support/plc/m-MotionSolutions.htm>.

Motion

IC800MCUB12 __ 0XN

IC800MCUB12 == 0XE

GFK-2209
July 2002

Stepping Motor Cube™ with Pulse and Direction Interface

This document provides reference information, and setup and installation procedures for Stepping Motor Cube models equipped with Pulse and Direction Inputs with or without the Optional Encoder.

1. SPECIFICATIONS	2
2. SETUP AND INSTALLATION	3
Wiring	3
General Wiring Considerations.....	3
System Power Wiring and Grounding.....	4
Motor and Drive Wiring.....	4
DB15 Logic Wiring	5
Motor Direction.....	6
Power Save.....	6
Status LED.....	6
Stall Behavior.....	6
DB9 Encoder Output Wiring	7
Installation Location	7
Overtemperature	7
3. MECHANICAL DRAWING	8
4. USER CONNECTIONS	9

1. Specifications

Table 1. Specifications for Stepping Motor Cube with Pulse & Direction Models

Pulse and Direction Inputs	
Input Format	+4 VDC Pulse/Direction; +24 VDC Pulse/Direction differential, optically isolated
Input Voltage Range	3.5 – 4.2 VDC for +4 V input; 12 – 30 VDC for +24 V input
Maximum Input Pulse Rate	50 kHz
Minimum Pulse Width	5 microseconds
Digital Inputs and Outputs	
Dedicated Inputs	Enable, power save
Dedicated Outputs	OK, Stall
Operating Range	4 – 24 VDC, 30 VDC maximum
Interface Format	optically isolated, source/sink user configurable
Maximum Off Input Voltage	1 VDC
Minimum On Input Voltage	4 VDC
Input Load	1K Ohms
Maximum On Output Resistance	35 Ohms
Maximum Load Output Current	100 mA
Maximum Off Output Leakage Current	200 nA
Differential Encoder Output (Optional)	
Output Format	differential, quadrature (line driver)
Line Count	500 pulses per revolution
Pulse Frequency	50 kHz maximum
Step Size Selection	200, 400, or 1,000 steps/revolution (See table 3.)
DC Input Power Requirements	
Drive Input Voltage Operating Range	24 VDC +/- 20% @ 2.4 Amps max (a) 48 VDC +/- 10% @ 2.4 Amps max (a)
Overvoltage Threshold	54 VDC +/-2 VDC
Undervoltage Threshold	18 VDC +/-2 VDC
Encoder Option Supply Voltage (for Pulse & Direction Models equipped with encoder option)	5 VDC @ 85 mA max.
Output Power	
Voltage range	17 to 38 Vrms 2 phase
Frequency	0 – 8 KHz fundamental (16.4 KHz PWM)
Current ^(b)	3 A rms per phase
Environmental Specifications	
Operating Temperature, Free Air Ambient	0 to 50 °C
Storage and Shipping Temperature	-40 to 80 °C
Enclosure Type	Open

Notes: (a) DC input power has undervoltage and overvoltage detection.

(b) The outputs are provided with internal overload protection. The IC800MCUB12160X_ model is 2.5 A rms per phase.

2. Setup and Installation

Wiring

Wiring diagrams for Stepping Motor Cube models are included in “User Connections.”

General Wiring Considerations

All power must be in accordance with Class I, Division 2 wiring methods as defined in Article 501-4(b) of the National Electrical Code, NFPA 70 for installations within the United States, or as specified in Section 18-152 of the Canadian Electrical Code for installation within Canada. Attach wiring connections for the main circuit according to table 2 while observing the following **cautions**:

Caution

Never connect AC main power to any terminal.

Never allow wire leads to contact the enclosure.

Never operate the unit without an earth ground.

Warning

When using this equipment in a Hazardous (classified) location:

- A. **WARNING--Explosion hazard--substitution of components may impair suitability for Class I, Division 2;**
- B. **WARNING--Explosion hazard--when in hazardous locations, turn off power before replacing or wiring modules;**
- C. **WARNING--Explosion hazard--do not disconnect equipment unless power has been switched off or the area is known to be nonhazardous.**

Table 2. Motor Cube Wiring Connections for Main Circuit

Pin	Description	Connect to	Wire Size AWG ^b
1	System Power +	24 or 48 VDC System Power Positive Connection ^a	22
2	Frame	Earth Ground	22
3	System Power – (Common)	24 or 48 VDC System Power Negative Connection ^a	22

Notes: (a) DC input power has undervoltage/overvoltage detection. Overvoltage threshold: 54 VDC +/-2 VDC. Undervoltage threshold: 18 VDC +/-2 VDC.

(b) Suggested maximum AWG size (i.e., minimum wire diameter) for stranded copper wire. Consult National Electrical Code Handbook ampacities tables for proper wire size.

System Power Wiring and Grounding

The DC power input connections are made to the connector located on the top of the Stepping Motor Cube. The unit is designed to operate with input voltages of 24 or 48 VDC.

Stepping Motor Cube power cables are available from GE Fanuc as IC800MCC23Pxxx, where x indicates the cable length of either 2 meters, 5 meters (xx = 05; xxx = 050) or 10 meters (xx = 10; xxx = 100). To connect Stepping Motor Cube power, connect the female three-pin power cable to the power connector on top of the unit. Connect the opposite end of the cable to your 24 or 48 VDC power supply.

Motor and Drive Wiring

The motor and drive components of the Stepping Motor Cube are factory wired and must not be disconnected. Do not attempt to remove the motor connector or to connect the drive electronics to any external motor.

Encoder Wiring

The option encoder connections are made to the DB9 connector located on the top of the Stepping Motor Cube. This encoder is a standard differential quadrature incremental encoder. Wiring information for the connections are shown in table 5.

Encoder cables are available from GE Fanuc as CBS-12-ED-03M-RA. This is a 3-meter long cable with a right-angle DB connector.

DB15 Logic Wiring

The pulse input and the direction input offer interface flexibility by providing inputs for either +24V or +4V operation. For example, when wiring for an input voltage operating range of +4V, pin 9 would connect to the pulse source output positive and pin 2 would connect to the pulse source output negative, while pin 1 would be left floating.

Warning

Do not connect a +24 VDC signal to a +4 VDC input. Circuit damage will result.

Observe input voltage range specifications from table 1.

Table 3. Motor Cube Wiring Connections for DB15 Logic I/O

Pin	Label	Description	Connect to	Wire Size AWG ^a
1	Pulse + (24V)	+24 VDC Pulse Input Positive	+24 VDC Pulse Source Output Positive	28
2	Pulse -	Pulse Input Negative	Pulse Source Output Negative	28
3	Direction + (4V)	+4 VDC Direction Input	+4 VDC Direction Source Output Positive	28
4	Input Common	Input Common	Common for Power Save and Enable Inputs	28
5	Power Save ^b	Power Save Input	Apply +4 to +24 VDC with respect to Pin 4 to Power Save	28
6	Stall Output ^c	Stall Output	Stall Output to User, Referenced from Pin 14	28
7	Step Size Select A ^d	Step Size Select A	Either Short to Pin 8 or leave open	28
8	Step Size Common ^d	Step Size Common	Pin 7 or Pin 15. DO NOT CONNECT TO INPUT COMMON.	28
9	Pulse + (4V)	+4 VDC Pulse Input Positive	+4 VDC Pulse Source Output Positive	28
10	Direction + (24V)	+24 VDC Direction Input	+24 VDC Direction Source Output Positive	28
11	Direction -	Direction Input Negative	Direction Output Negative	28
12	Enable Input	Enable Input	Apply +4 to +24 VDC with Respect to Pin 4 to Enable. Sink or source current per discrete I/O diagram shown in the <i>User Connections</i> section of this manual to enable the drive. If open, or floating, the drive is disabled.	28
13	OK Output ^c	OK Output	OK Output to User Referenced from Pin 14	28
14	Output Common	Output Common	Common Ground for OK and Stall Outputs	28
15	Step Size Select B ^d	Step Size Select B	Either short to Pin 8 or leave open	28

Notes: a. Suggested maximum AWG size (i.e., minimum wire diameter) for stranded copper wire. Consult National Electrical Code Handbook ampacities tables for proper wire size.

b. For 100% continuous current, sink or source current per discrete I/O diagram shown in “User Connections.”
If open, or floating, current is reduced to 60%.

c. Output on, or true, = internally shorted to output common pin 14; output off, or false = internally open to output common pin 14.

d. Step Size Selection:

A	B	Step Size
open	open	Full Stepping (200 steps/rev)
open	short	Half Stepping (400 steps/rev)
short	open	Microstepping (1,000 steps/rev)

Short = Connect to Step Size Common

Motor Direction

Determine motor direction by viewing the motor shaft from the front of the Motor Cube. The motor shaft rotates clockwise under the following conditions:

Clockwise voltage applied to +4V direction input is < 3.5 VDC
 voltage applied to +24V direction input is < 12 VDC

The motor shaft rotates counterclockwise under the following conditions:

Counterclockwise voltage applied to +4V direction input = 3.5 – 4.2 VDC
 voltage applied to +24V direction input = 12 – 30 VDC

The +24V and +4V direction inputs are on the DB15 connector located on the top of the Stepping Motor Cube. See table 3 and the “User Connections” section for pin connections.

Power Save

The Power Save feature allows the user to select 100% or 60% continuous current. The 60% current power save setting will reduce motor heating and input power consumption. You can apply 60% current selectively or continuously. Selective 60% continuous current, for example, could be applied when the motor is stopped yet enabled. Continuous 60% continuous current would result in reduced torque performance. See table 3 on the previous page for Power Save wiring connections.

Status LED

The Status LED, located on the top of the unit next to the power connector, indicates the drive states described in table 4.

Table 4. Status LED States

Status LED State	Drive Condition	
Off	Under Voltage	Check power supply & wiring
One Repeating Flash	Stall Condition	Check motor load; use slower accel/decel. Check motor wiring.
Two Repeating Flashes	Over Temperature	Use Power Save feature; reduce duty cycle; bolt to heatsink or add fan cooling.
Three Repeating Flashes	Over Current	Check motor wiring
Four Repeating Flashes	Over Voltage	Check power supply & wiring
Repeating On/Off (50% Duty Cycle)	Lost Enable	Check enable signal wiring for errors or broken wires.
On	Enabled/OK	--

The Undervoltage, Over Temperature, Over Current, Over Voltage, and Lost Enable fault conditions disable the drive in the Stepping Motor Cube.

Stall Behavior

A STALL CONDITION DOES NOT DISABLE THE DRIVE. During a stall condition, the stall output is turned on, but the drive remains enabled. Monitor the stall output to determine the stall state of the Motor Cube.

When the drive is disabled during a stall condition, the Status LED indicates the stall condition with one repeating flash. The stall velocity threshold for all Stepping Motor Cube models is 4 RPS.

DB9 Encoder Output Wiring

The encoder outputs (Channel A, Channel B, and Index) are differential outputs.

Table 5. Motor Cube Wiring Connections for DB9 Encoder

Pin	Label	Description	Connect to	Wire Size AWG ^a
1	Channel A+	Channel A Positive Output	Positive Input of Differential Receiver for Channel A	28
2	Channel B+	Channel B Positive Output	Positive Input of Differential Receiver for Channel B	28
3	Index +	Index Positive	Positive Input of Differential Receiver for Index	28
4	+ 5V	+5 VDC Supply	+5 VDC Supply Referenced to Pin 5	28
5	Gnd	Ground	Common for Encoder Supply	28
6	Channel A-	Channel A Negative Output	Negative Input of Differential Receiver for Channel A	28
7	Channel B-	Channel B Negative Output	Negative Input of Differential Receiver for Channel B	28
8	Index -	Index Negative Output	Negative Input of Differential Receiver for Index	28
9	Gnd	Ground	Common for Encoder Supply	28

Note: (a) Suggested maximum AWG size (i.e., minimum wire diameter) for stranded copper wire. Consult *National Electrical Code Handbook* ampacities tables for proper wire size.

Installation Location

Location of the Stepping Motor Cube is important to achieve proper performance and operating life. The unit is designed with "open" construction. The unit must be installed in an enclosure that protects personnel from contact with wiring terminals and provides a pollution degree 2 environment (per the *IEC 664-1* documentation) that protects the unit from:

- Corrosive gases or liquids
- Vibration
- Conductive pollution including extreme or condensing humidity and airborne metallic particles
- Accidental contact by persons using the equipment
- Temperature extremes beyond the equipment ratings.

It is possible to reduce condensation and high humidity by providing ventilation or by applying continuous heat through the use of heaters or continuous energizing of the equipment when it is in use. Continuous energizing is considered to exist when the equipment is operated with interruptions of a duration that do not permit cooling to the point of condensation to occur.

Overtemperature

The Stepping Motor Cube has an overtemperature detection circuit. When the temperature of the logic electronics (located inside the Motor Cube enclosure) reaches 80°C +/- 5%, the drive will fault and become disabled. Built-in 5°C to 10°C hysteresis requires that the Motor Cube must cool to below 70 °C before it can be enabled following an overtemperature condition.

3. Mechanical Drawing

The Stepping Motor Cube with Pulse and Direction is available in three motor frame sizes, in the model configurations provided below.

Table 6. Mechanical Dimensions

Pulse & Direction Model	L1	L2	Weight	Inertia oz-in-sec ²
IC800MCUB12160XN	2.700"	3.700"	1.6 lbs	0.0010
C800MCUB12210XN		4.200"	2.1 lbs	0.0017
IC800MCUB12310XN		5.200"	3.1 lbs	0.0036
Pulse & Direction with Encoder Model	L1	L2	Weight	Inertia oz-in-sec ²
IC800MCUB12160XE	3.500"	4.500"	1.8 lbs	0.0010
IC800MCUB12210XE		5.000"	2.3 lbs	0.0017
IC800MCUB12310XE		6.000"	3.3 lbs	0.0036

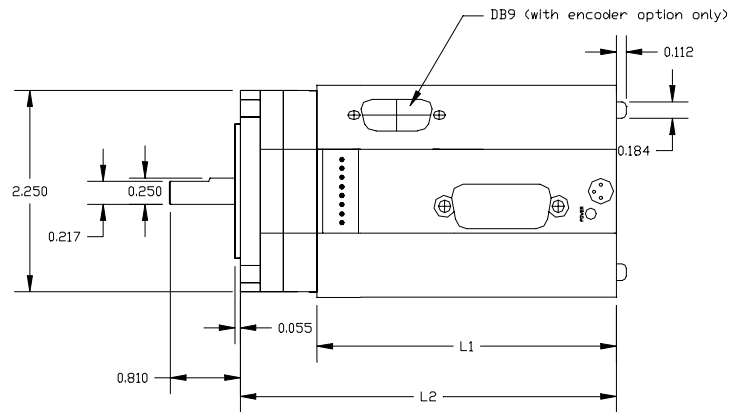

Stepping Motor Cube, Top View

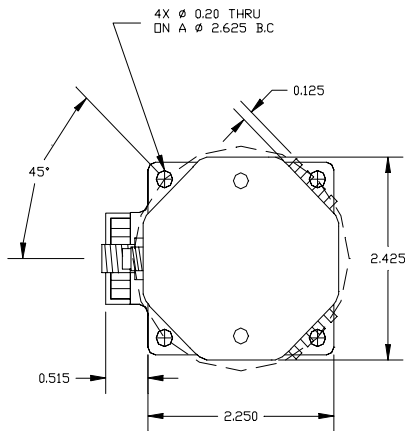

Stepping Motor Cube, Back View

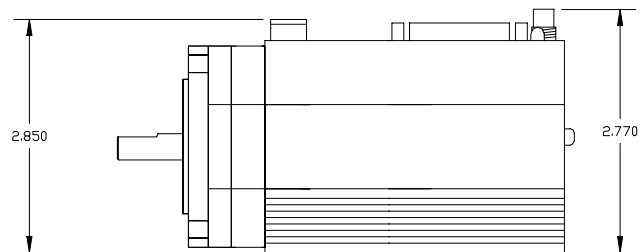

Stepping Motor Cube, Side View

4. User Connections

Pulse & Direction Models
IC800MCUB12160XN
IC800MCUB12210XN
IC800MCUB12310XN
Pulse & Direction with Encoder Models
IC800MCUB12160XE
IC800MCUB12210XE
IC800MCUB12310XE

ENCODER OUTPUT OPTION

DB9 connector available on Pulse & Direction models with encoder option

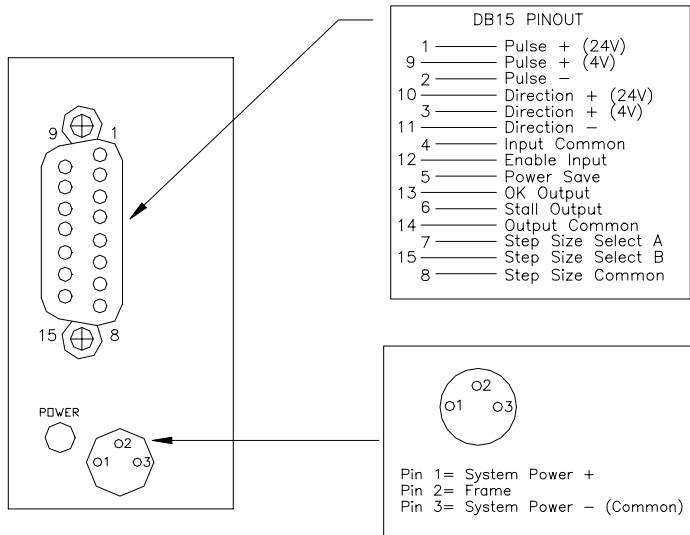
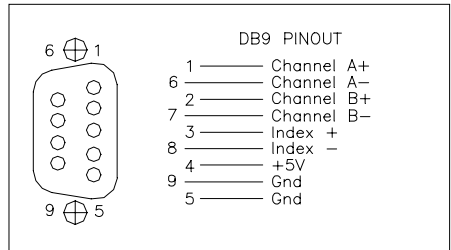

Step Size Selection

A	B	Step Size
open	open	Full Stepping (200 steps/rev)
open	short	Half Stepping (400 steps/rev)
short	open	Microstepping (1,000 steps/rev)

Short = connect to Step Size Common

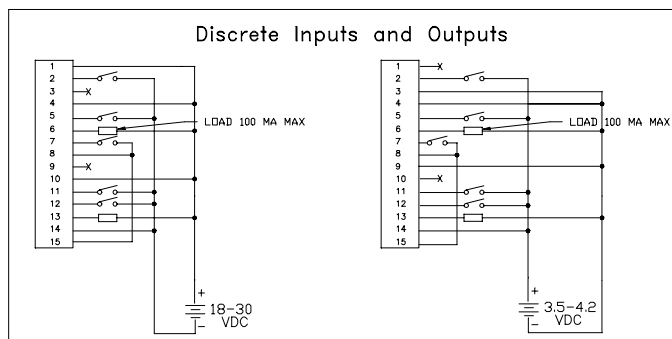

24V Sink Connector

4V Source Connector