

# Applied Solution – DSM Motion Management

The DSM Motion Management applied solution is a Proficy Machine Edition Project that includes LD-PLC code and View Screens for the application of DSM314 and DSM324i servo systems into PACSystems RX3i motion applications. The solution is complete and ready for integration into any application requiring DSM servo systems. The project could also be used as a baseline for development of other DSM drive types such as S2K or other 3rd party motion interfaces.

The DSM Motion Management applied solutions supports uncoordinated DSM servo motion. Documentation is included that outlines the integration and use of the available LD-PLC code and View Screens into any Proficy Machine Edition application.

Supported functions include:

- Set Axis Position
- Find Home Position
- Position Moves
- Incremental Moves
- Jog Moves
- Get Axis Position
- Module and Axis Diagnostics
- Reset Module or Axis Errors
- User defined X/Y CAM Motion Profiles

Download this applied solution from: <http://globalcare.gefanuc.com/>  
 Select "Software Downloads"  
 Select "Developer Downloads"  
 Select "Applied Solutions" folder  
 Select "DSM Motion Management" folder

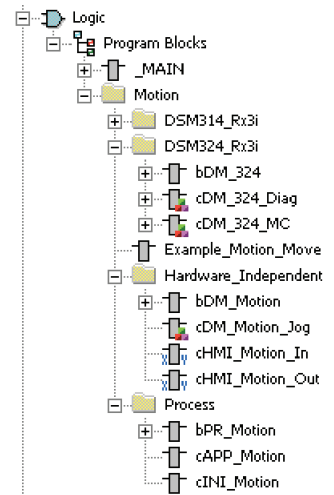

## GE Fanuc Automation Information Centers

Americas:  
1 800 GE FANUC or 434 978 5100

Asia Pacific:  
86 21 3222 4555

Europe, Middle East and Africa:  
800 1 GE FANUC or 800 1 4332682  
or 1 780 401 7717

Europe, Middle East and Africa (CNC):  
352 727979 1

©2006 GE Fanuc Automation. All Rights Reserved.  
All other brands or names are property of their respective holders.

## Additional Resources

For more information, please visit the GE Fanuc web site at:

[www.gefanuc.com](http://www.gefanuc.com)

