



GE Fanuc Automation

Programmable Control Products

Field Control™
Distributed I/O and Control System

Profibus Bus Interface Unit
User's Manual

GFK1291A

September 1996

Warnings, Cautions, and Notes as Used in this Publication

Warning

Warning notices are used in this publication to emphasize that hazardous voltages, currents, temperatures, or other conditions that could cause personal injury exist in this equipment or may be associated with its use.

In situations where inattention could cause either personal injury or damage to equipment, a Warning notice is used.

Caution

Caution notices are used where equipment might be damaged if care is not taken.

Note

Notes merely call attention to information that is especially significant to understanding and operating the equipment.

This document is based on information available at the time of its publication. While efforts have been made to be accurate, the information contained herein does not purport to cover all details or variations in hardware or software, nor to provide for every possible contingency in connection with installation, operation, or maintenance. Features may be described herein which are not present in all hardware and software systems. GE Fanuc Automation assumes no obligation of notice to holders of this document with respect to changes subsequently made.

GE Fanuc Automation makes no representation or warranty, expressed, implied, or statutory with respect to, and assumes no responsibility for the accuracy, completeness, sufficiency, or usefulness of the information contained herein. No warranties of merchantability or fitness for purpose shall apply.

The following are trademarks of GE Fanuc Automation North America, Inc.

Alarm Master	Field Control	Modelmaster	Series One
CIMPLICITY	GEnet	ProLoop	Series Six
CIMPLICITY	Genius	PROMACRO	Series Three
PowerTRAC	Genius PowerTRAC	Series Five	VuMaster
CIMPLICITY 90-ADS	Helpmate	Series 90	Workmaster
CIMSTAR	Logicmaster		

Content of this Manual

This manual describes the Field Control™ Profibus Bus Interface Unit (IC670PBI001). It explains operation of the Bus Interface Unit as a Profibus device.

Chapter 1. Introduction: Chapter 1 introduces Field Control™ modules, the Profibus Bus Interface Unit (IC670PBI001), and other equipment that may be used with the Bus Interface Unit.

Chapter 2. Installation: Chapter 2 describes installation procedures for the Bus Interface Unit.

Chapter 3. Autoconfiguration: Chapter 3 explains the features of Autoconfiguration, which automatically configures the operation of the I/O Station and enables it to start exchanging I/O and diagnostics data with the master.

Chapter 4. Instructions for Using a Hand-held Programmer: Chapter 4 explains how to use a Hand-held Programmer with a Profibus BIU.

Chapter 5. Operation: Chapter 5 is a general description of the operation of the Profibus BIU.

Chapter 6. Communications: Chapter 6 explains how Profibus master devices communicate with the Profibus Bus Interface Unit. The communications described in this chapter are controlled by the master through the application program. Specific Profibus system programming instructions are not included.

Related Publications

For more information, refer to these publications:

FieldControl™ I/O Modules User's Manual (GFK-0826). This book describes Field Control I/O Modules and I/O Terminal Blocks and explains how to install them.

We Welcome Your Comments and Suggestions

At GE Fanuc automation, we strive to produce quality technical documentation. After you have used this manual, please take a few moments to complete and return the Reader's Comment Card located on the next page.

Jeanne Grimsby
Senior Technical Writer

Chapter 1	Introduction	1-1
	Overview	1-1
	Field Control Modules	1-2
	Locations for Field Control	1-4
	Field Control Environmental Specifications	1-5
	Profibus Bus Interface Unit	1-6
	Bus Interface Unit Terminal Block	1-10
	Bus Interface Unit Functional Specifications	1-11
	Configuration	1-12
	Hand-held Programmer	1-12
	Profibus	1-13
 Chapter 2	 Installation	 2-1
	Preinstallation Check	2-2
	Static Protection	2-2
	Conformance to Standards	2-2
	Removing the Bus Interface Unit from the Terminal Block	2-3
	Installing the DIN Rail	2-4
	Installing the Bus Interface Unit Terminal Block on the DIN Rail	2-5
	Setting the BIU DIP Switches	2-6
	Installing the Cables Between Terminal Blocks	2-8
	Installing the Bus Interface Unit on the Terminal Block	2-9
	Removing the Bus Interface Unit from the Terminal Block	2-9
	System Wiring Guidelines	2-10
	System Grounding	2-11
	Power Wiring to the Bus Interface Unit	2-12
	Connecting the Communications Bus	2-13
	Bus Termination	2-15
	Observing the LEDs	2-16
	Removing/Replacing the Bus Interface Unit Fuse	2-17
	Removing the Bus Interface Unit Terminal Block	2-18
	Upgrading the BIU Firmware	2-19
 Chapter 3	 Autoconfiguration	 3-1
	Description	3-2
	Input and Output References Assigned by Autoconfiguration	3-3
	Hand-held Programmer Settings for Autoconfiguration	3-5
	Autoconfiguration with a Hand-Held Programmer	3-5
	Notes about Adding and Deleting Modules	3-6

Contents

Chapter 4	Instructions for Using a Hand-held Programmer	4-1
	Getting Started	4-2
	Displaying and Editing BIU Configuration Data	4-4
	Performing and Disabling Autoconfiguration	4-6
	Enabling or Disabling I/O Scanning	4-7
	Configuring the BIU Manually	4-8
	Configuring I/O Modules Manually	4-10
	Monitoring and Forcing I/O Data	4-24
	Displaying and Clearing Faults with the HHP	4-26
Chapter 5	Operation	5-1
	Overview	5-1
	I/O Data	5-2
	Diagnostics	5-4
	Synchronizing I/O Data	5-6
Chapter 6	Communications	6-1
	Profibus Operation	6-1
	Timing	6-2
	Communications between the Master and the BIU	6-2
	BIU Communications States	6-3
	Reading BIU Diagnostics: DDLM_Slave_Diag	6-5
	Setting the BIU Communications Parameters: DDLM_Set_Prm	6-7
	Checking the BIU Configuration: DDLM_Chk_Cfg	6-9
	Exchanging I/O Data, Diagnostics, and Fault Clearing: DDLM_Data_Exchange	6-11
	Synchronizing I/O Data: DDLM_Global Control	6-13
	Additional Messages for Programming Devices (Class 2 Masters)	6-14

Chapter 1

Introduction

This chapter describes Field Control™ modules, the Profibus Bus Interface Unit (IC670PBI001), and other equipment that may be used with the Bus Interface Unit. It will help you locate more information in other documents.

Overview

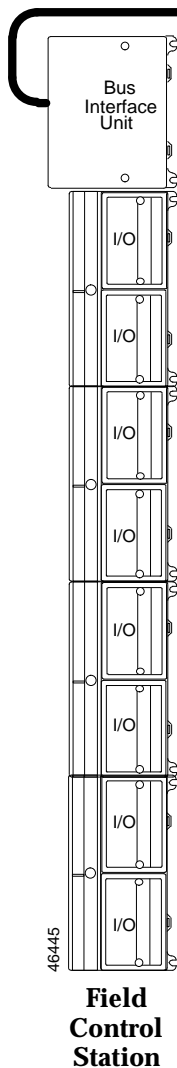

**Field
Control
Station**

Field Control is a family of highly-modular distributed I/O and control products. They are suitable for use in a wide range of host architectures.

The heart of the Field Control system is the Bus Interface Unit. The Bus Interface Unit provides intelligent processing, I/O scanning, and feature configuration for a group of up to eight I/O modules. Together, the Bus Interface Unit and its modules make up a Field Control station (see the illustration, left).

The Bus Interface Unit and I/O modules are enclosed in sturdy, compact aluminum housings. Bus Interface Unit and I/O modules bolt securely to separate Terminal Blocks, which provide all field wiring terminals. The I/O Terminal blocks are generic and allow different I/O module types to be mounted on the same base. I/O Terminal Blocks are available with box-type terminals, barrier-type terminals, or wire-to-board connectors. All Terminal Blocks must be mounted on a DIN rail. The DIN rail, which serves as an integral part of the grounding system, can also be mounted on a panel.

Field Control Features

Features and benefits of Field Control include:

- wiring savings
- more up time
- easy installation and maintenance
- spare parts savings
- low cost
- feature flexibility
- open architecture / adaptable to a variety of networks
- distributed I/O
- small, compact I/O modules with generic terminal wiring bases
- DIN rail mounted

Field Control Modules

There are three basic types of Field Control modules:

- **Bus Interface Unit.** The illustration below shows a Profibus Bus Interface Unit.
- **I/O modules**
- **Terminal Blocks:**
 - Bus Interface Unit Terminal Block.
 - I/O Terminal Blocks, each of which accommodates two I/O modules.
 - Auxiliary Terminal Blocks. These optional terminal strips can be connected to the side of an I/O Terminal Block if extra common terminals are needed.

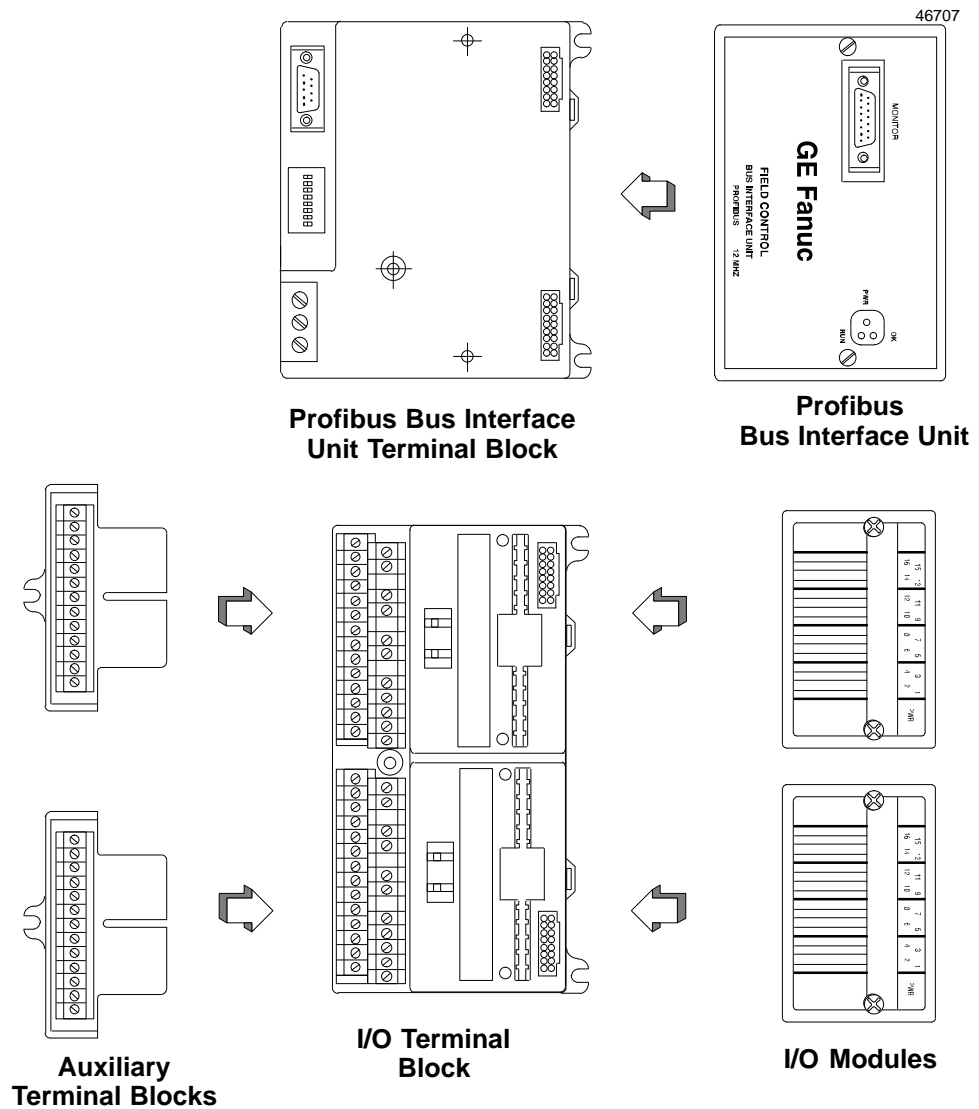

Profibus Bus Interface Unit

The Profibus Bus Interface Unit interfaces Field Control I/O modules to a Profibus I/O bus.

The intelligent processing capabilities of the Profibus Bus Interface Unit allow the configuration of features such as fault reporting, selectable input and output defaults, analog scaling and analog range selection for the modules in the station. In addition, the Profibus Bus Interface Unit performs diagnostic checks on itself and its I/O modules, and relays diagnostic information to the host (if configured for fault reporting) and to a Hand-held Programmer.

The Bus Interface Unit mounts on a Bus Interface Unit Terminal Block. The Bus Interface Unit can be removed and replaced if necessary without removing the wiring or reconfiguring the I/O station.

Bus Interface Unit Terminal Block

The Bus Interface Unit Terminal Block provides connections for power wiring and single or dual communications cables. The Bus Interface Unit Terminal Block stores the configuration parameters selected for the station.

I/O Modules

Field Control I/O Modules are available in many types to suit a wide range of application needs. Modules can be installed and removed without disturbing field wiring. One or two I/O modules may be mounted on an I/O Terminal Block.

I/O Terminal Blocks and Auxiliary I/O Terminal Blocks

An I/O Terminal Block provides mounting, electrical, and field wiring connections. Each half of the I/O Terminal Block can be mechanically keyed to accept only an I/O module of a specific type. Auxiliary I/O Terminal Blocks can be easily attached to an I/O Terminal Block. They provide the extra connections needed for analog and high-density discrete modules.

For more information, please refer to:

- *Chapter 2: Installation*, which explains wiring to the Bus Interface Unit, and explains how to install the Bus Interface Unit module on the Field Terminal Block.
- *Chapter 5: Operation*, which explains how the Profibus Bus Interface Unit services I/O.
- The ***Field Control I/O Modules User's Manual***, which describes I/O modules and I/O Terminal Blocks. This manual also explains module installation and field wiring.

Locations for Field Control

The Profibus Bus Interface Unit and Field Control I/O modules can be located on equipment, in junction boxes, inside panels, behind operator stations, and in other locations where space is limited. The area should be clean, free of airborne contaminants, and provide adequate cooling. Field Control modules can be installed in NEMA enclosures. The enclosure can be as little as 4 inches (10.16 cm) deep. A 35mm x 7.5mm DIN rail is required.

The Bus Interface Unit Terminal Block and up to four I/O Terminal Blocks are grouped together using the connection cables provided. All of the I/O Terminal Blocks in a group must be connected either before or after the Bus Interface Unit. A Bus Interface Unit may not be connected between I/O Terminal Blocks.

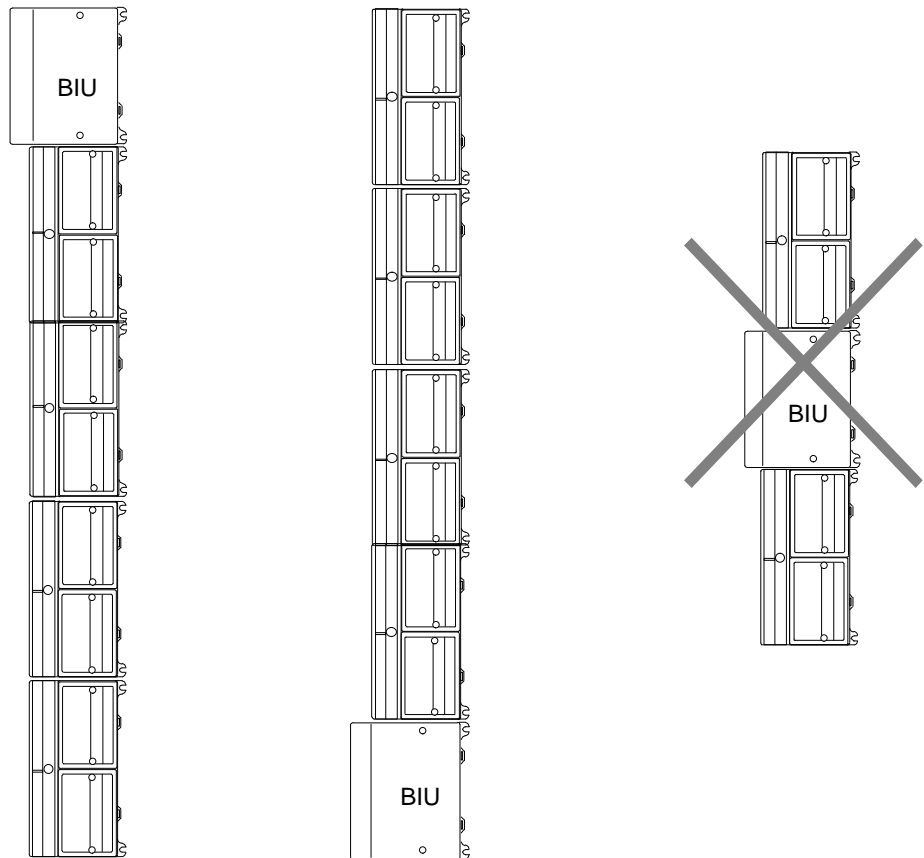

46405

Terminal Blocks can be mounted in any orientation without derating the modules' temperature specification.

Field Control Environmental Specifications

Vibration	Modules perform well where vibration is a factor. Modules are installed on a panel-mounted DIN rail using the clamp supplied, and with the panel-mounting feet secured. For information about vibration standards, please see the <i>Conformance to Standards</i> document (GFK-1179).
Noise	Modules are resistant to noise levels found in most industrial applications when installed according to accepted practices, including proper separation of wiring by voltage and power level. Modules must be installed on a conductive (unpainted) DIN rail. The DIN rail is an integral part of the grounding system. Modules are tested to the specifications listed in the <i>Conformance to Standards</i> document (GFK-1179).
Temperature	Modules operate reliably in ambient air temperatures from 0C (32F) up to 55C (131F). Storage temperatures are -40C (-40F) to +85C (185F).
Humidity	5% to 95%, non-condensing.

For detailed installation information, please see:

- Chapter 2 of this manual. It describes installation and wiring for the Bus Interface Unit module and terminal block.
- Chapter 2 of the *FieldControl I/O Modules User's Manual*. It summarizes installation instructions for modules and terminal blocks. Detailed installation instructions are also packed with individual Field Control modules.
- The individual module datasheets included in the *FieldControl I/O Modules User's Manual*, which provide specific module wiring information.
- *Conformance to Standards* (GFK-1179). This manual describes the installation requirements for programmable control products used in industrial environments, specifically, in situations where compliance to standards or directives from the Federal Communications Commission, the Canadian Department of Communications, or the European Union is necessary. The information in this manual is applicable for GE Fanuc Series 90-70 and Series 90-30 programmable controller products, Genius I/O products, and Field Control Distributed I/O and Control products.

Profibus Bus Interface Unit

The Profibus Bus Interface Unit is a small, rugged, intelligent module with a sturdy aluminum housing. The module has three status LEDs and a connector for a Hand-held Programmer.

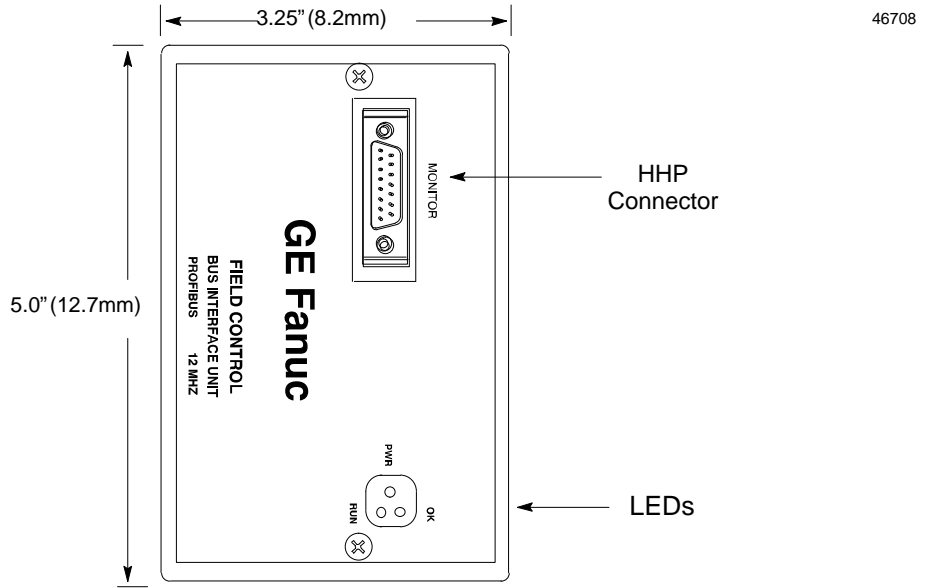

The Bus Interface Unit requires an external source of 24 VDC power.

The BIU's internal power supply provides power for the operation of the BIU itself, and logic power for the I/O modules connected to it.

It mounts on a separate terminal block, to which it and all field wiring are attached. The configuration is stored in non-volatile memory located in the terminal block.

The Bus Interface Unit has a replaceable 1A, 5x20mm 250VAC slow-blow fuse on the input power lines. The fuse can be changed without disturbing the wiring of any other modules.

Bus Interface Unit Power Supply

The 24 VDC power supply in the Bus Interface Unit provides power for the Bus Interface Unit itself and logic power for all I/O modules that may potentially be installed at that station. External power must be supplied for field wiring of input and output devices. Specifications for the BIU power supply are listed on page 1-11.

The BIU power supply is not damaged by either of the following:

- Reversing input voltage on terminals 1 and 2.
- *Temporary* overcurrent conditions on the 6.5 VDC output.

Timing

The Bus Interface Unit provides power to all I/O modules that are installed at the station. I/O module operation is governed by a System Reset signal to ensure controlled operation during the power up and shut down processes. As shown in the timing diagram below, momentary power losses of less than 10 milliseconds do not affect I/O module operation; however, longer power losses generate a Reset for all system I/O modules.

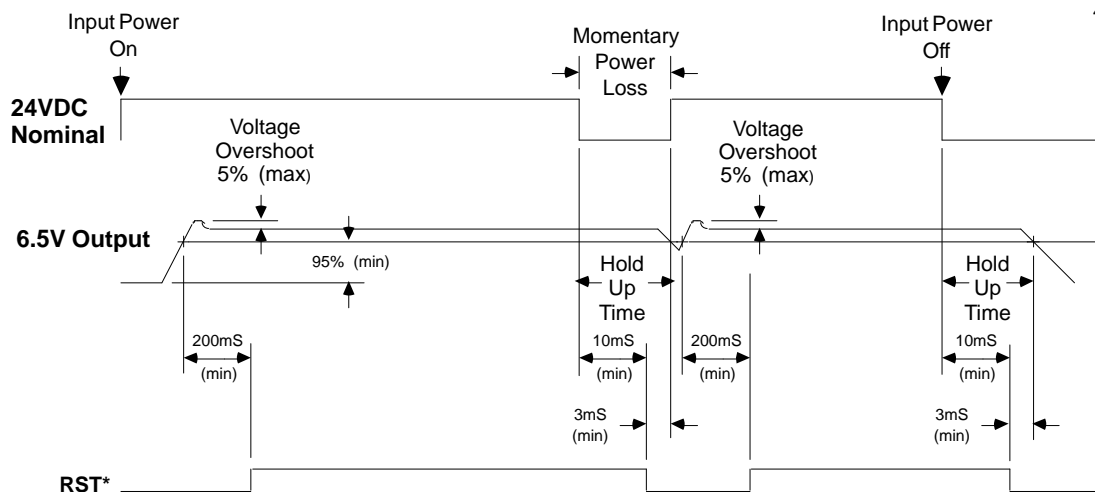

46456

Backplane Current

The amount of current available to the backplane depends on the minimum input voltage as shown in the following graph. Systems operating with less than 21 V input voltage have less backplane current available. For example, at 20V_{in} the available current is 1.2 Amps.

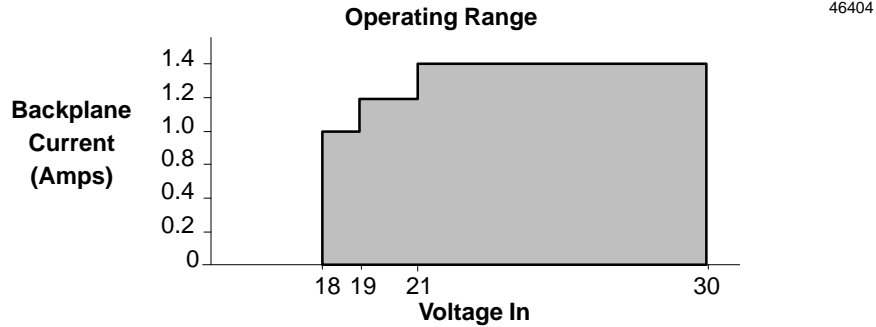

Calculating Input Power Requirements for a Bus Interface Unit

The chart below shows typical input power requirements for the 24 VDC power supply.

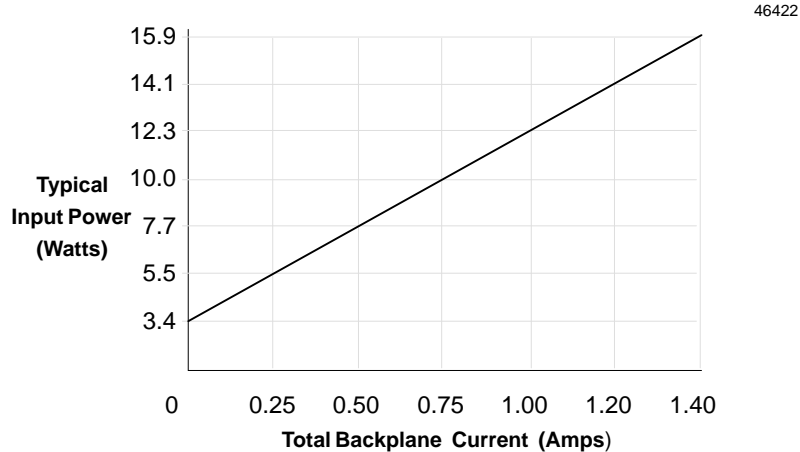

Note

Start-up surge at full load is 15–50 Amps for 3 milliseconds (maximum).

To determine specific system requirements:

- Determine total output load from typical specifications listed for individual modules.
- Use the lower graph to determine average input power.
- Divide the input power by the operating source voltage to determine the input current requirements.
- Use the lowest input voltage to determine the maximum input current.
- Allow for startup surge current requirements. Startup surge current levels are a function of source impedance and, therefore, are installation-dependent. Startup surge currents can vary between 25A and 50A for approximately 3mS.
- Allow margins (10% to 20%) for variations.

Bus Interface Unit Power Dissipation

The Bus Interface Unit power dissipation can be determined once the backplane current supplied to the I/O modules is known. The following equation can be used to calculate BIU power dissipation:

$$\text{BIU Power Dissipation} = \text{Input Power} - (\text{total backplane current} \times 6.5 \text{ volts})$$

For example:

- A. Total backplane current = 0.5 Amps
- B. Typical Input power = 7.7 Watts

Therefore:

$$\text{BIU Power Dissipation} = 7.7 \text{ W} - (0.5 \times 6.5) = 4.45 \text{ Watts}$$

Load Requirements for Hardware Components

The table below shows the DC load required by each module and hardware component. All ratings are in milliamps. Input and Output module current ratings are with all inputs or outputs on. These are maximum requirements, not typical.

Catalog Number	Description	Current (mAmps)
IC670MDL233	Input Module, 120 VAC 8 Isolated Points	40
IC670MDL240	Input Module, 120 VAC 16 Grouped Points	77
IC670MDL241	Input Module, 16 Points, 2 groups 240 VAC	77
IC670MDL640	Input Module, 24 VDC 16 Grouped Pos/Neg Points	83
IC670MDL641	Input Module, 48 VDC 16 Grouped Pos/Neg Points	83
IC670MDL642	Input Module, 125 VDC 16 Grouped Pos/Neg Points	77
IC670MDL643	Input Module, 5/12 VDC 16 Point	80
IC670MDL644	Input Module, 12/24 VDC 16 Grouped Pos/Neg Fast Inputs	80
IC670MDL730	Output Module, 8 Pt 24 VDC Electronic Short Circuit Protection	125
IC670MDL740	Output Module, 12/24 VDC 0.5 Amp, 16 Grouped Pos.	111
IC670MDL742	Output Module, 5/12/24 VDC Negative Outputs	111
IC670MDL330	Output Module, 16 Point 12-120 VAC 16 Pt 1.0 Amp	285
IC670MDL331	Output Module, 120 VAC 2 Amp, 8 Isolated Points	154
IC670MDL930	Relay Output Module, 2 Amp, 6 Form A Points and 2 Isolated Form C Points	313
IC670ALG230	Analog Current Input Module, 8 Grouped Points	51
IC670ALG240	Analog Input Module, 16 point Grouped	251
HE670ACC100	Input Simulator Module, Horner	100
HE670ADC810	Analog Input Module, Horner, +/-10VDC, 0-10 VDC	131
IC670ALG620	RTD Input Module	190
IC670ALG630	Thermocouple Input Module	195
IC670ALG320	Analog Current/Voltage Output Module, 4 Grp Points	51
IC670ALG330	Analog Current source Output Module, 8 Points	85
IC670MFP100	Micro Field Processor	111
IC693PRG300	Hand-held Programmer	170
IC660HHM501	Genius Hand-held Monitor	0

* When attached, the Hand-held Programmer must be considered as a load component in the system.

Bus Interface Unit Terminal Block

The Bus Interface Unit provides terminals for bus, power and ground connections. Maximum wire size is AWG #14. (avg 2.0690mm² cross-section).

A connecting cable is provided with each I/O Terminal Block. It is used to connect the Bus Interface Unit Terminal Block to the first I/O Terminal Block. The same type of cable interconnects subsequent I/O Terminal Blocks. The cable has molded connectors that are keyed to assure proper orientation.

The Bus Interface Unit Terminal Block is designed to be extremely reliable; it should not be necessary to replace or rewire it after installation.

The Bus Interface Unit Terminal Block stores the configuration parameters for the station. The Bus Interface Unit can be removed without removing the wiring or reconfiguring the station.

DIP switches on the Terminal Block can be used to set the Profibus Address that will be used by the BIU. The BIU reads these switch settings at powerup. (If they are changed while the BIU is operating, the change will not take effect until the next time the BIU is powered up.)

The Profibus Address can also be set during BIU configuration.

46709

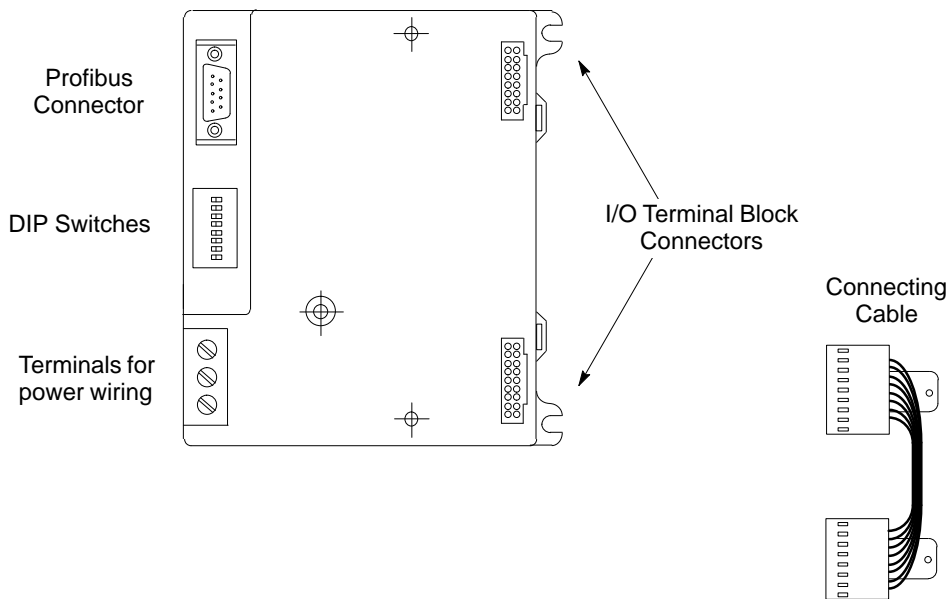

Bus Interface Unit Functional Specifications

<p>Bus Interface Unit:</p> <ul style="list-style-type: none"> Reliability Power Supply Input <ul style="list-style-type: none"> Nominal Rated Voltage Voltage Range Power Inrush Current Power Supply Output to I/O modules: Holdup Time 	<p>More than 183,000 hours operation MTBF, calculated</p> <p>24 VDC</p> <p>18 VDC to 30 VDC</p> <p>16.8 Watts maximum at full load (nominal voltage)</p> <p>15-50 Amps peak, 3 mS maximum (see note)</p> <p>6.5 VDC \pm5%</p> <p>1.4 Amp maximum. See module list on page 1-9.</p> <p>10mS maximum from nominal input voltage.</p>
<p>Bus Interface Unit Terminal Block:</p> <ul style="list-style-type: none"> Power Requirements Reliability 	<p>16mA maximum</p> <p>More than 600,000 hours operation MTBF, calculated</p>

Note: Inrush current is installation dependent. See page 2-4.

For power requirements of specific I/O modules, please see the *Field Control I/O Modules User's Manual*, (GFK-0826).

Configuration

The Profibus BIU and the Field Control I/O modules are shipped with a set of default operating characteristics that can be used as-is in many applications.

At powerup the BIU will automatically read the configuration of the modules installed in the I/O Station and create the overall configuration for the I/O Station. The BIU stores the configuration in non-volatile memory in the BIU Terminal Block., where it is protected against power loss.

As soon as the master establishes communication with the BIU, it is ready to start exchanging I/O and diagnostics data.

Custom Configuration

The BIU can also be configured with a Hand-held Programmer:

- to assign non-default values to the modules in the I/O Station
- to configure modules which are not installed at the time of configuration
- to configure modules located after empty slots in the I/O Station
- To edit an existing configuration.

For more information, please see:

Chapter 4, *Using a Hand-held Programmer.*

The *Hand-held Programmer Manual* (GFK-0402) for basic HHP operating instructions.

Hand-held Programmer

The Hand-held Programmer provides a convenient portable operator interface to the Bus Interface Unit and I/O modules.

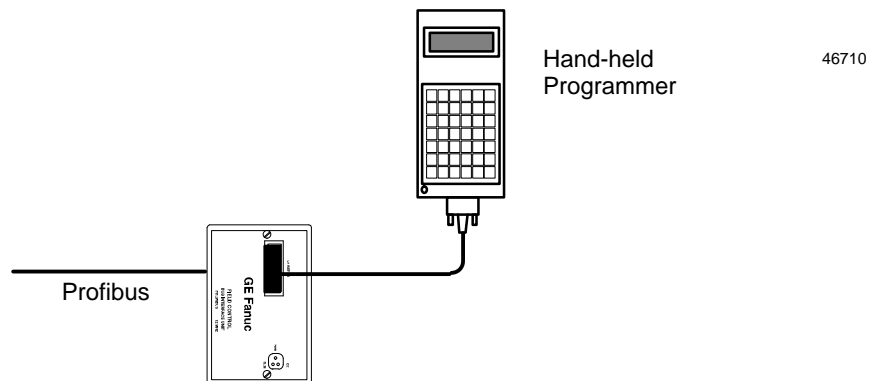

The Hand-held Programmer can be used to monitor, force I/O and unforce I/O, and to display diagnostics.

Profibus

Profibus is a serial fieldbus that is used for both inter-control and I/O information. Profibus consists of several separate protocols, the most common of which are Profibus-FMS and Profibus-DP. Profibus-FMS is used for communication between controllers, where communications services are more important than system reaction time. Profibus-DP is used for high-speed data transfer at the I/O level, including sensors and actuators. The GE Fanuc Field Control Profibus BIU supports Profibus-DP protocol. Profibus serves both master and slave devices.

- Master devices are able to control the bus. When it has the right to access the bus, a master may transfer messages without remote request.
- Slave devices are simple peripheral devices such as sensors, actuators, transmitters, or a modular I/O unit such as the GE Fanuc Field Control Profibus BIU. Slaves have no bus access rights—they may only acknowledge received messages, or at the request of a master, transmit messages to that master.

The protocol architecture of Profibus is based on the Open Systems Interconnection (OSI) reference model in accordance with the international standard ISO 7498.

Bus Specifications

NetworkTopology	Linear bus, terminated at both ends. Stubs are possible.
Medium	Shielded twisted pair cable. Shielding may be omitted, depending on the environment.
NumberofStations	32 stations in every segment without repeaters. With repeaters, extendible up to 127.
TransmissionSpeed	9.6, 19.2, 93.75, 187.5, 500, 1500 Kbits, 3 Mbits, 6 Mbits, 12 Mbits.
Connector	9-pin D-subconnector

Chapter 2

Installation

This chapter describes installation procedures for the Bus Interface Unit.

- Preinstallation Check
- Static Protection
- Removing the Bus Interface Unit from the Terminal Block
- Installing the DIN Rail
- Installing the Bus Interface Unit Terminal Block on the DIN Rail
- Installing the Cables Between Terminal Blocks
- Setting the BIU DIP Switches
- Installing the Bus Interface Unit on the Terminal Block
- Removing the Bus Interface Unit from the Terminal Block
- System Wiring Guidelines
- System Grounding
- Power Wiring to the Bus Interface Unit
- The Communications Bus
- Observing the LEDs
- Removing/Replacing the Bus Interface Unit Fuse
- Removing the Bus Interface Unit Terminal Block from the DIN Rail
- Upgrading the BIU Firmware

Preinstallation Check

Carefully inspect all shipping containers for damage during shipping. If any part of the system is damaged, notify the carrier immediately. The damaged shipping container should be saved as evidence for inspection by the carrier.

As the consignee, it is your responsibility to register a claim with the carrier for damage incurred during shipment. However, GE Fanuc will fully cooperate with you, should such action be necessary.

After unpacking the Field Control modules and other equipment, record all serial numbers. Serial numbers are required if you should need to contact Product Service during the warranty period of the equipment.

All shipping containers and all packing material should be saved should it be necessary to transport or ship any part of the system.

Static Protection

The Bus Interface Unit has CMOS components that are susceptible to static damage. *Use proper static handling techniques when handling this module.*

Conformance to Standards

Before installing Field Control products in situations where compliance to standards or directives from the Federal Communications Commission, the Canadian Department of Communications, or the European Union is necessary, please refer to GE Fanuc's *Installation Requirements for Conformance to Standards*, GFK-1179.

Removing the Bus Interface Unit from the Terminal Block

The Bus Interface Unit is shipped pre-installed on the BIU Terminal Block.
Remove it to install the connector cable to the first I/O Terminal Block.

- 1. Loosen the Bus Interface Unit retaining screws.

Caution

Be sure screws are fully disengaged. Attempting to remove the module with screw(s) partially engaged may damage it.

- 2. Pull the Bus Interface Unit module straight away from the Terminal Block.

Caution

Do not tilt the Bus Interface Unit to remove it. Attempting to remove the Bus Interface Unit at an angle may damage it.

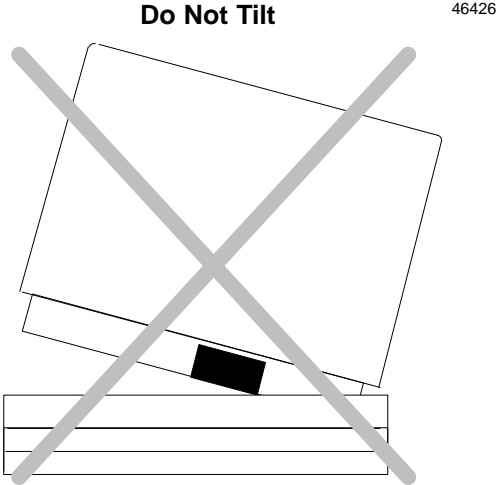

Installing the DIN Rail

AllField Control Terminal Blocks must be mounted on a 7.5mm x 35mm DIN rail. The rail must have a conductive (unpainted) finish for proper grounding. For best vibration resistance, the DIN rail should be installed on a panel using screws spaced approximately 6 inches (5.24cm) apart. When using multiple rail sections, be sure they are properly aligned. Mount the DIN rail at least 4.25 inches (10.80 cm) from any wireway or other obstruction *on the wiring side of the Bus Interface Unit*. Allow more space if the wiring for I/O modules is very stiff.

Drill mounting holes for the BIU Terminal Block as shown below. Allow a small tolerance between the top and bottom of adjacent terminal blocks.

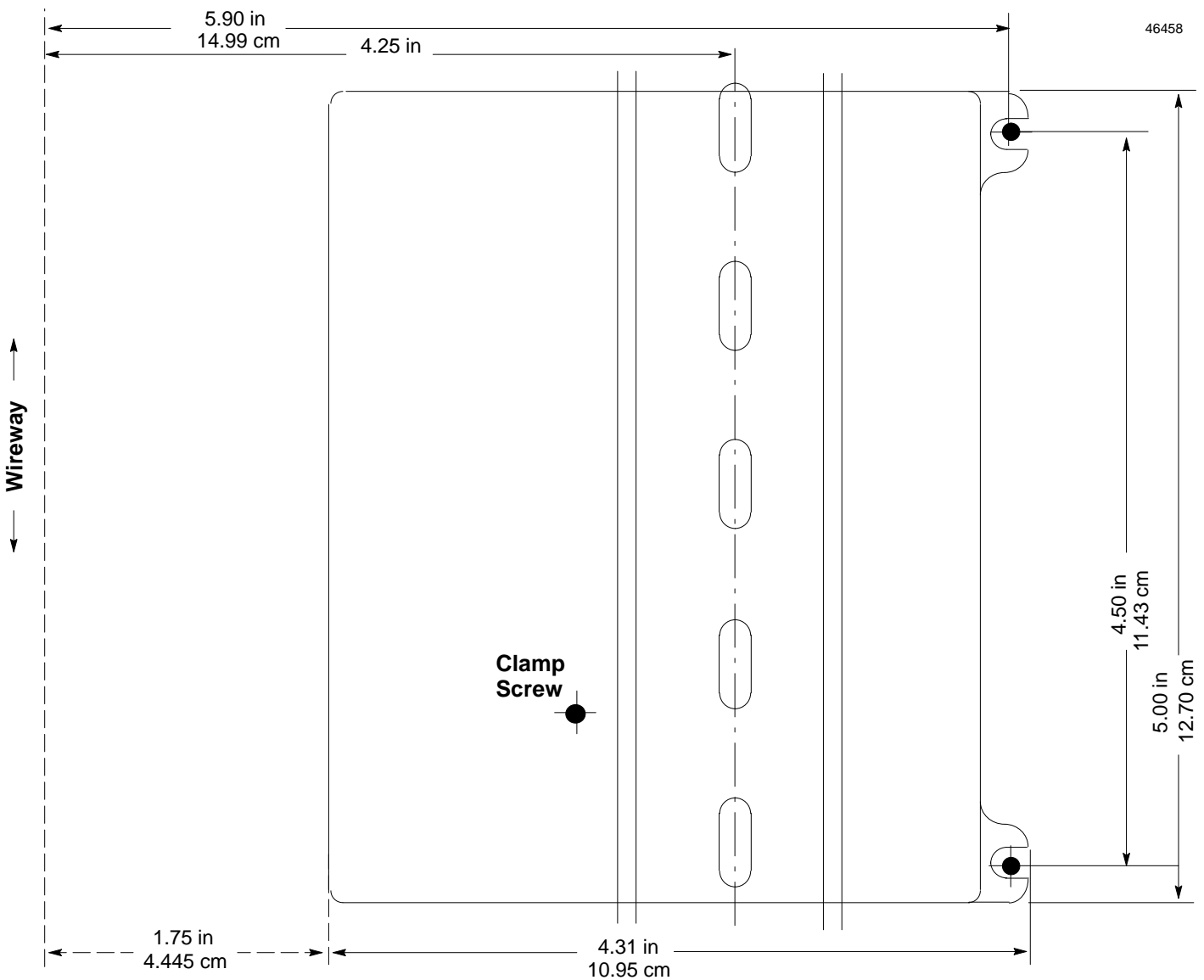

Installing the Bus Interface Unit Terminal Block on the DIN Rail

1. Tilt the Bus Interface Unit Terminal Block and position it over the rail, as shown below left, catching the rail behind the tabs in the terminal block.
2. Pivot the terminal block downward until the spring-loaded DIN rail latches in the terminal block click into place.

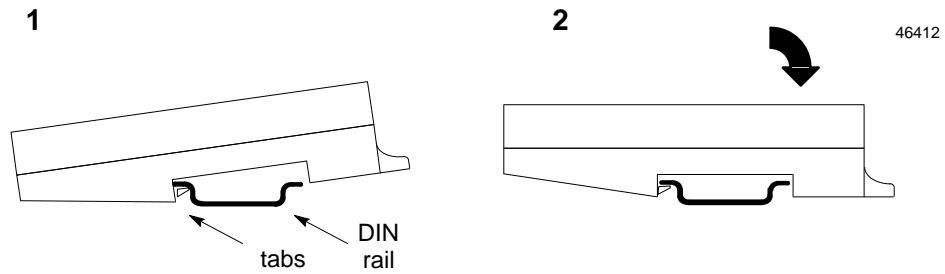

3. Tighten the DIN rail clamp screw (see below left). Maximum recommended torque is 8 in./lbs to 10 in./lbs.

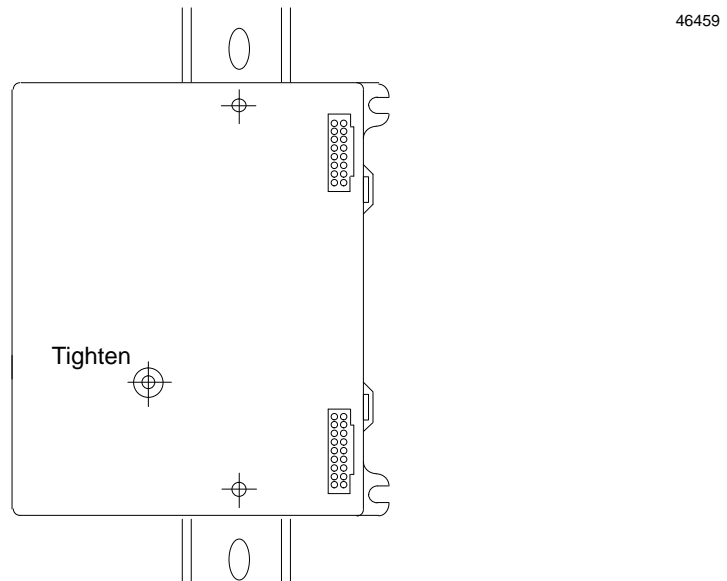

4. Secure the terminal block to the panel with 3/8 inch (9.525mm) #6 screws (not supplied) through the mounting ears.

Setting the BIU DIP Switches

The DIP switch pack on the BIU Terminal Block can be used to assign the bus ID of the BIU. Each device on the bus must have a unique ID. Valid bus addresses are 1 to 126.

Note

The master will not exchange I/O data with a device that uses ID 126, so do not use 126 for the BIU (also see below).

Switch 8 determines whether the Profibus ID is read from memory or from DIP switches.

To have the Profibus ID read from memory, set switch 8 to the off position. If the address in memory is invalid, a default address of 126 is used. If switch 8 is set to on (to Read ID from DIP switches) BUT switches 1– 7 are set to on (127 decimal), the ID, the default address of 126 decimal is used.

To use the DIP switches to select the ID, set switch 8 to the on position and position switches 1 – 7 to select the bus ID, as shown in the table on the next page.. The illustration below shows the DIP switches positioned to have switch 1 on the right to correspond with the table of switch settings.

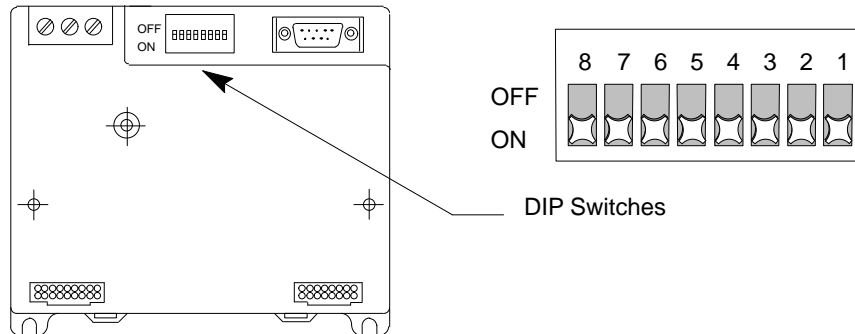

The following table shows switch settings for selecting bus IDs 0 to 127. Switch settings are binary. In the table, the least significant bit (switch 1) is on the right.

Switch Positions for Selecting the Bus ID

8	7	6	5	4	3	2	1	Bus ID	8	7	6	5	4	3	2	1	Bus ID
on	off	off	off	off	off	off	off	0	on	on	off	off	off	off	off	off	64
on	off	off	off	off	off	off	on	1	on	on	off	off	off	off	off	on	65
on	off	off	off	off	off	on	off	2	on	on	off	off	off	off	on	off	66
on	off	off	off	off	off	on	on	3	on	on	off	off	off	off	on	on	67
on	off	off	off	off	on	off	off	4	on	on	off	off	off	on	off	off	68
on	off	off	off	off	on	off	on	5	on	on	off	off	off	on	off	on	69
on	off	off	off	off	on	on	off	6	on	on	off	off	off	on	on	off	70
on	off	off	off	off	on	on	on	7	on	on	off	off	off	on	on	on	71
on	off	off	off	on	off	off	off	8	on	on	off	off	on	off	off	off	72
on	off	off	off	on	off	off	on	9	on	on	off	off	on	off	off	on	73
on	off	off	off	on	off	on	off	10	on	on	off	off	on	off	on	off	74
on	off	off	off	on	off	on	on	11	on	on	off	off	on	off	on	on	75
on	off	off	off	on	on	off	off	12	on	on	off	off	on	on	off	off	76
on	off	off	off	on	on	off	on	13	on	on	off	off	on	on	off	on	77
on	off	off	off	on	on	on	off	14	on	on	off	off	on	on	on	off	78
on	off	off	off	on	on	on	on	15	on	on	off	off	on	on	on	on	79
on	off	off	on	off	off	off	off	16	on	on	off	on	off	off	off	off	80
on	off	off	on	off	off	off	on	17	on	on	off	on	off	off	off	on	81
on	off	off	on	off	off	on	off	18	on	on	off	on	off	off	on	off	82
on	off	off	on	off	off	on	on	19	on	on	off	on	off	off	on	on	83
on	off	off	on	off	on	off	off	20	on	on	off	on	off	on	off	off	84
on	off	off	on	off	on	on	off	21	on	on	off	on	off	on	off	on	85
on	off	off	on	off	on	on	off	22	on	on	off	on	off	on	on	off	86
on	off	off	on	off	on	on	on	23	on	on	off	on	off	on	on	on	87
on	off	off	on	on	off	off	off	24	on	on	off	on	on	off	off	off	88
on	off	off	on	on	off	off	on	25	on	on	off	on	on	off	off	on	89
on	off	off	on	on	off	on	off	26	on	on	off	on	on	off	on	off	90
on	off	off	on	on	off	on	on	27	on	on	off	on	on	off	on	on	91
on	off	off	on	on	on	off	off	28	on	on	off	on	on	on	off	off	92
on	off	off	on	on	on	off	on	29	on	on	off	on	on	on	off	on	93
on	off	off	on	on	on	on	off	30	on	on	off	on	on	on	on	off	94
on	off	off	on	on	on	on	on	31	on	on	off	on	on	on	on	on	95
on	off	on	off	off	off	off	off	32	on	on	on	off	off	off	off	off	96
on	off	on	off	off	off	off	on	33	on	on	on	off	off	off	off	on	97
on	off	on	off	off	off	on	off	34	on	on	on	off	off	off	on	off	98
on	off	on	off	off	off	on	on	35	on	on	on	off	off	off	on	on	99
on	off	on	off	off	on	off	off	36	on	on	on	off	off	on	off	off	100
on	off	on	off	off	on	off	on	37	on	on	on	off	off	on	off	on	101
on	off	on	off	off	on	on	off	38	on	on	on	off	off	on	on	off	102
on	off	on	off	off	on	on	on	39	on	on	on	off	off	on	on	on	103
on	off	on	off	on	off	off	off	40	on	on	on	off	on	off	off	off	104
on	off	on	off	on	off	off	on	41	on	on	on	off	on	off	off	on	105
on	off	on	off	on	off	on	off	42	on	on	on	off	on	off	on	off	106
on	off	on	off	on	off	on	on	43	on	on	on	off	on	off	on	on	107
on	off	on	off	on	on	off	off	44	on	on	on	off	on	on	off	off	108
on	off	on	off	on	on	off	on	45	on	on	on	off	on	on	off	on	109
on	off	on	off	on	on	on	off	46	on	on	on	off	on	on	on	off	110
on	off	on	off	on	on	on	on	47	on	on	on	off	on	on	on	on	111
on	off	on	on	off	off	off	off	48	on	on	on	on	off	off	off	off	112
on	off	on	on	off	off	off	on	49	on	on	on	on	off	off	off	on	113
on	off	on	on	off	off	on	off	50	on	on	on	on	off	off	on	off	114
on	off	on	on	off	off	on	on	51	on	on	on	on	off	off	on	on	115
on	off	on	on	off	on	off	off	52	on	on	on	on	off	on	off	off	116
on	off	on	on	off	on	off	on	53	on	on	on	on	off	on	off	on	117
on	off	on	on	off	on	on	off	54	on	on	on	on	off	on	on	off	118
on	off	on	on	off	on	on	on	55	on	on	on	on	off	on	on	on	119
on	off	on	on	on	off	off	off	56	on	on	on	on	on	off	off	off	120
on	off	on	on	on	off	off	on	57	on	on	on	on	on	off	off	on	121
on	off	on	on	on	off	on	off	58	on	on	on	on	on	off	on	off	122
on	off	on	on	on	off	on	on	59	on	on	on	on	on	off	on	on	123
on	off	on	on	on	on	off	off	60	on	on	on	on	on	on	off	off	124
on	off	on	on	on	on	off	on	61	on	on	on	on	on	on	off	on	125
on	off	on	on	on	on	on	off	62	on	on	on	on	on	on	on	off	126
on	off	on	on	on	on	on	on	63	on	on	on	on	on	on	on	on	127

Installing the Cables Between Terminal Blocks

Before installing modules on their terminal blocks, install the connecting cable(s) between terminal blocks. A short connecting cable, as illustrated below, is supplied with each I/O Terminal Block. A set of 12 connecting cables is available as renewal part number IC670ACC001. Optional 21 inch (0.53 meter) cable (part number IC670CBL002) is also available (only one longer cable can be used per I/O station).

The illustration below shows cable connection between a Bus Interface Unit terminal block and an I/O Terminal Block. Make connections between I/O Terminal Blocks in the same manner. The connectors are keyed to assure proper installation.

After installing the cable, be sure it is firmly seated on both connectors.

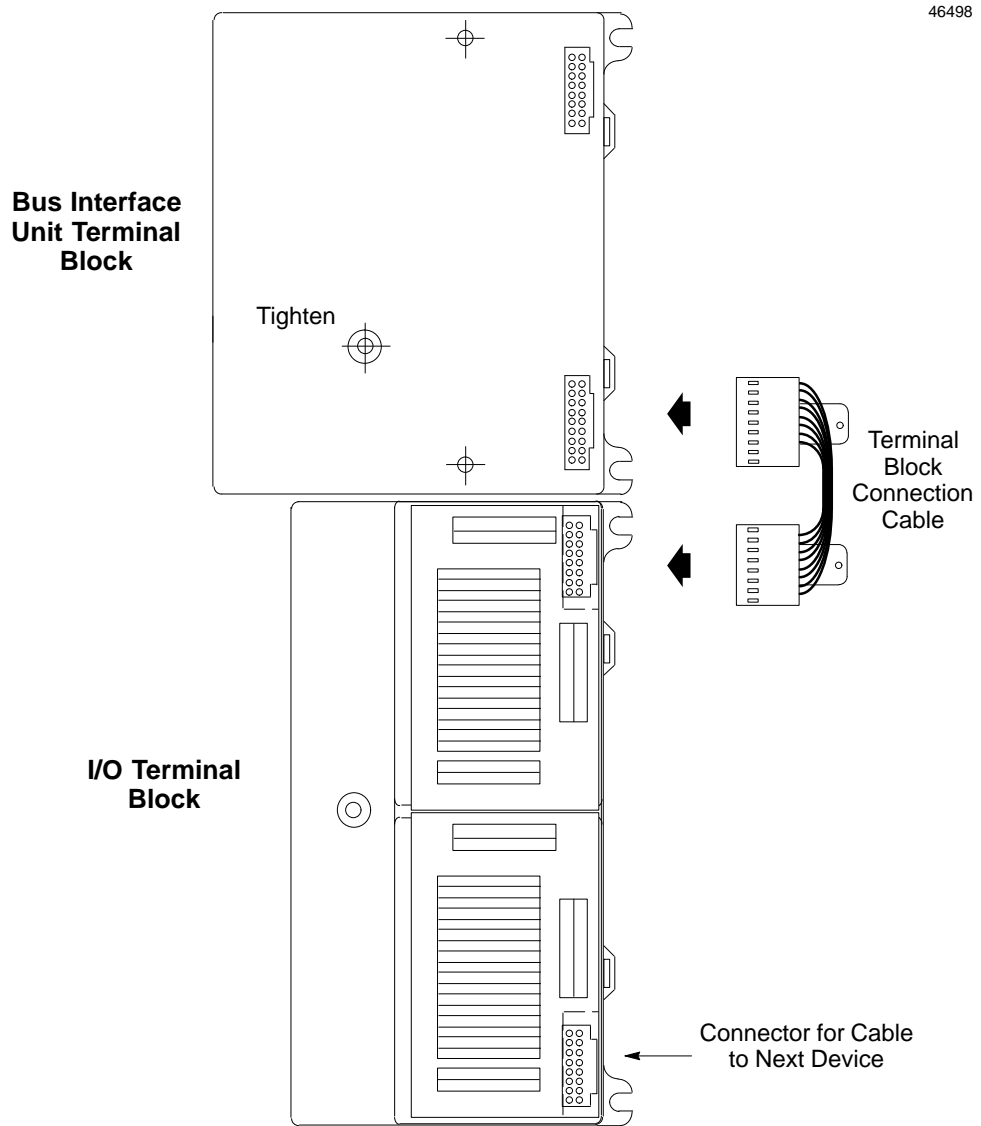

Installing the Bus Interface Unit on the Terminal Block

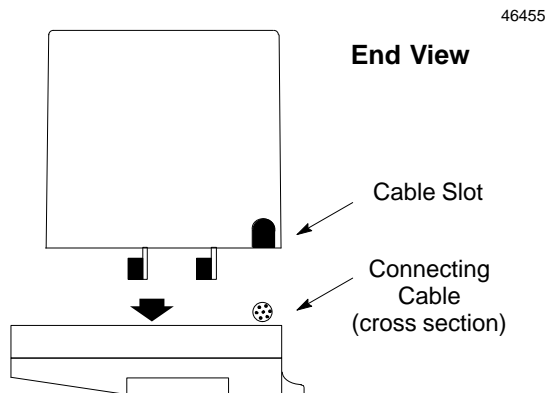

1. Power must be OFF when installing the BIU.
2. Before installing a new BIU, remove the cable slot knockout on the end of the module that will cover the connecting cable. It can be removed with pliers, or by pressing *out* from inside the module housing.
3. Position the BIU module so that the cable slot in the module housing is over the connecting cable. Press the module down firmly.

Caution

Do not exert excessive force; it may damage the equipment.

4. After placing the Bus Interface Unit onto the terminal block, tighten its screws to secure it. Maximum recommended torque is 9 in/lbs.

Removing the Bus Interface Unit from the Terminal Block

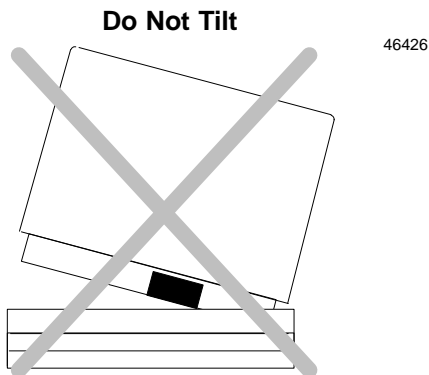

1. Power to the I/O Station should be Off.
2. Loosen the Bus Interface Unit retaining screws.

Caution

Be sure screws are fully disengaged. Attempting to remove the module with screw(s) partially engaged may damage the equipment.

3. Pull the Bus Interface Unit module straight away from the Terminal Block.

Caution

Do not tilt the Bus Interface Unit to remove it. Attempting to remove the Bus Interface Unit at an angle may damage the equipment.

System Wiring Guidelines

Four types of wiring may be encountered in a typical factory installation:

1. Power wiring – the plant power distribution, and high power loads such as high horse-power motors. These circuits may be rated from tens to thousands of KVA at 220 VAC or higher.
2. Control wiring – usually either low voltage DC or 120 VAC of limited energy rating. Examples are wiring to start/stop switches, contactor coils, and machine limit switches. This is generally the interface level of discrete I/O.
3. Analog wiring – transducer outputs and analog control voltages. This is the interface level to I/O analog blocks.
4. Communications and signal wiring – the communications network that ties everything together, including computer LANs, MAP, and Profibus and Genius busses.

These four types of wiring should be separated as much as possible to reduce the hazards from insulation failure, miswiring, and interaction (noise) between signals. A typical PLC system may require some mixing of the latter three types of wiring, particularly in cramped areas inside motor control centers and on control panels.

In general, it is acceptable to mix the communications bus cable with the I/O wiring from the blocks, as well as associated control level wiring. All noise pickup is cumulative, depending on both the spacing between wires, and the distance span they run together. I/O wires and communications bus cable can be placed randomly in a wiring trough for lengths of up to 50 feet. If wiring is cord-tied (harnessed), do not include the bus cable in the harness, since binding wires tightly together increases the coupling and mechanical stress that can damage the relatively soft insulation of some serial cable types.

Consider using shielded cable in noisy environments.

Wiring which is external to equipment, and in cable trays, should be separated following National Electrical Code practices.

Installing Additional Suppression

It is possible some installations might exceed the surge immunity capabilities of the Bus Interface Unit. This is most likely in outdoor installations or where the power source is from another building or ground system. It is prudent to provide local transient protection.

Transient suppression is most effective when installed at the load.

System Grounding

All components of a control system and the devices it controls must be properly grounded. Ground conductors should be connected in a star fashion, with all branches routed to a central earth ground point as shown below. This ensures that no ground conductor carries current from any other branch.

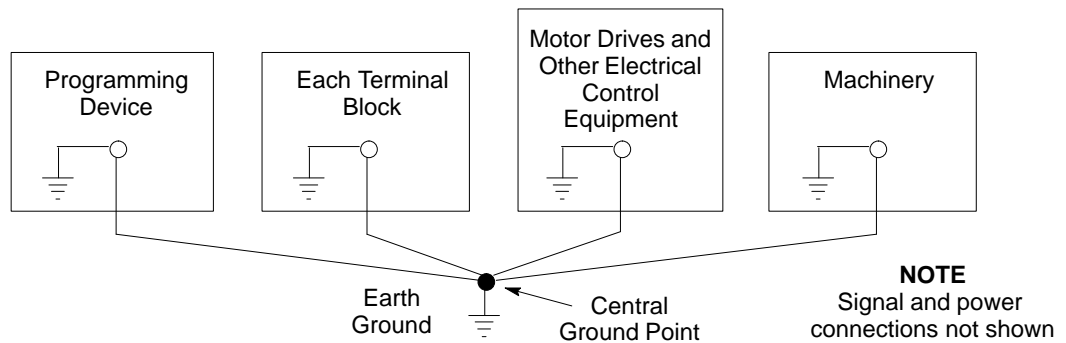

Each Field Control Terminal Block has a chassis ground terminal for safety and noise protection. This terminal should be connected to the conductive mounting panel with a 4-inch maximum length of AWG #14 (avg 2.1mm²) wire. Use hardware such as star washers to ensure ground integrity.

The control panel and enclosure should also be bonded to the plant system ground per code. Inadequate grounding may compromise system integrity in the presence of power switching transients and surges.

Power Wiring to the Bus Interface Unit

1. Connect an appropriate source of 24 VDC (nominal) to the Bus Interface Unit Terminal Block as shown below. **Do not apply power yet.**

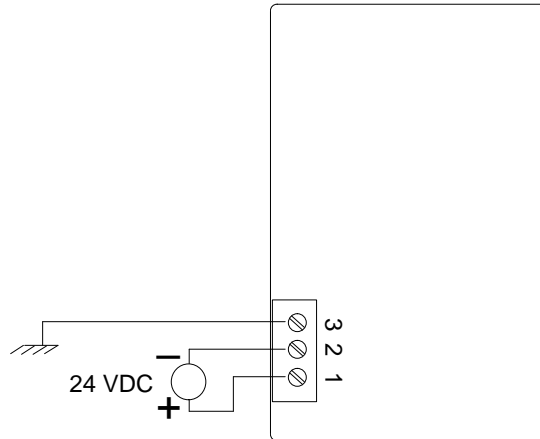

2. Connect the ground terminal to chassis ground using an AWG #14 (avg 2.1mm²) stranded wire.

Connecting the Communications Bus

Attach Profibus cable to the connector on the front of the Bus Interface Unit.

46712

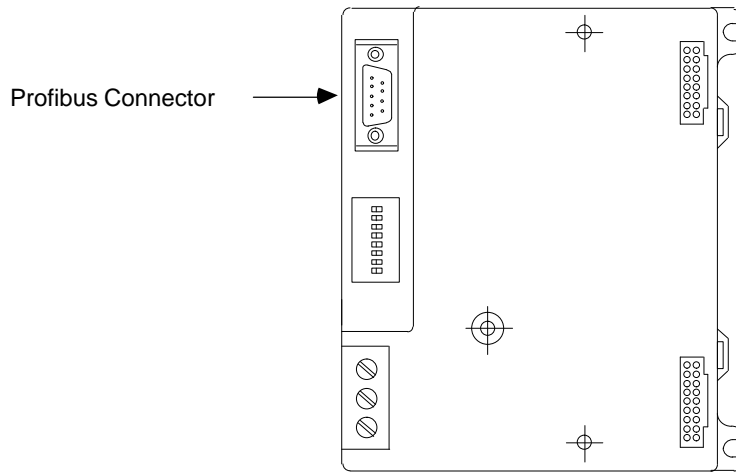

Pin Assignments for the Profibus Connectors

The diagram below shows pin assignments for the Profibus connector.

46713

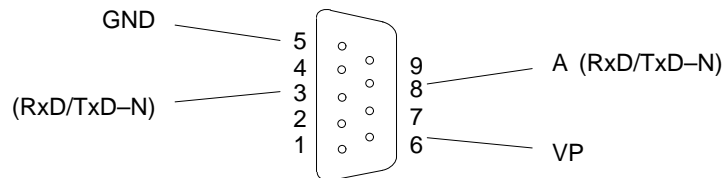

Bus Cable Types

Profibus DP can use cables of either type listed below.

Parameter	Cable Type A: Profibus DP	Cable Type B: DIN 19245 Part 1/4.91, Section 3.1.2.3
Impedance	135 to 165 Ohms (3 to 20 MHz)	100 to 300 Ohms (f > 100 kHz)
Capacity	< 30 pF per meter	< 60 pF per meter
Resistance	< 110 Ohms per Kilometer	-
Wire Gauge	> 0.64 mm	> . 0.53 mm
ConductorArea	> 0.34 mm ²	> 0.22 mm ²

For data rates up to 500 kbits/second, the stub recommendations of Profibus Part 1 should be applied. At 1500 kbits/second the overall drop capacity should be less than 0.2nF. The maximum length of the stub at 1500 kbits/second of cable type A (Profibus DP) is 6.6 meters.

Bus Length

The maximum bus length depends on the data rate, as shown in the following table.

Maximum Bus Length in Meters	Kbits per Second
1,200	9.6
1,200	19.2
1,200	93.75
600	187.5
400	500
200	1,500
100	12,000

Bus Termination

For type B cable, termination resistors are needed, as defined in DIN 19245 Part1/4.91 section 3.1.2.5.

For type A cable, which has higher line impedance, the following bus termination resistors are needed:

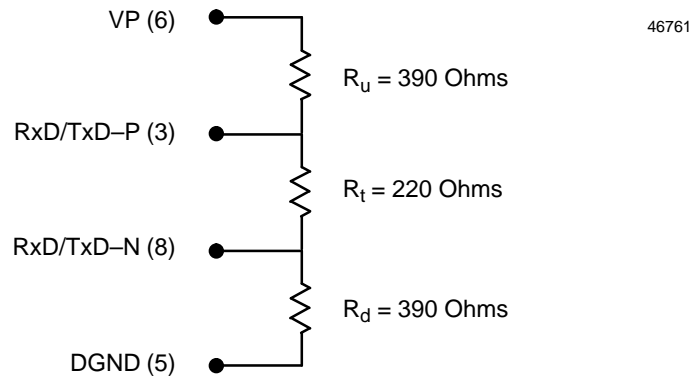

Compensation for 12 Mbit Busses

In addition to the termination shown above, the following compensation should be added for 12 Mbit bus technology:

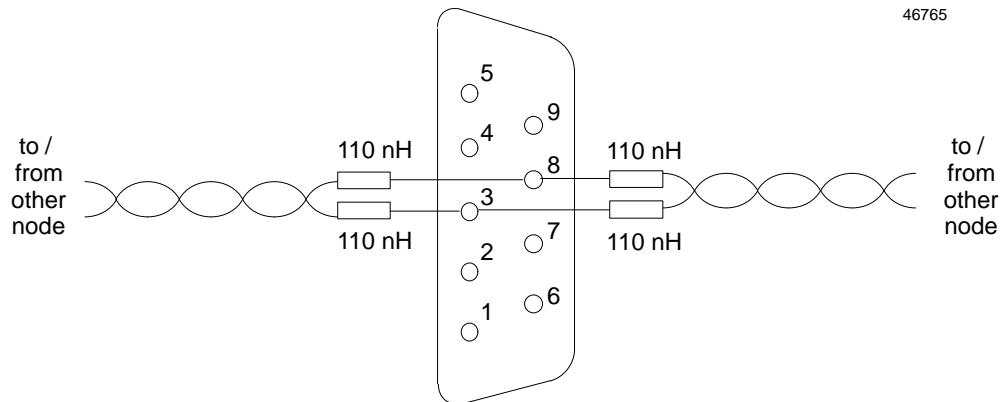

Additional Information

For detailed information about Profibus system cable installation requirements, please contact the Profibus Trade Organization at the address below.

Profibus Trade Organization
5010 East Shea Blvd, Suite C-226
Scottsdale, AZ. 85254

Phone Number: (602) 483-2456

Observing the LEDs

When power is applied, the LEDs on the BIU indicate operating and communications status.

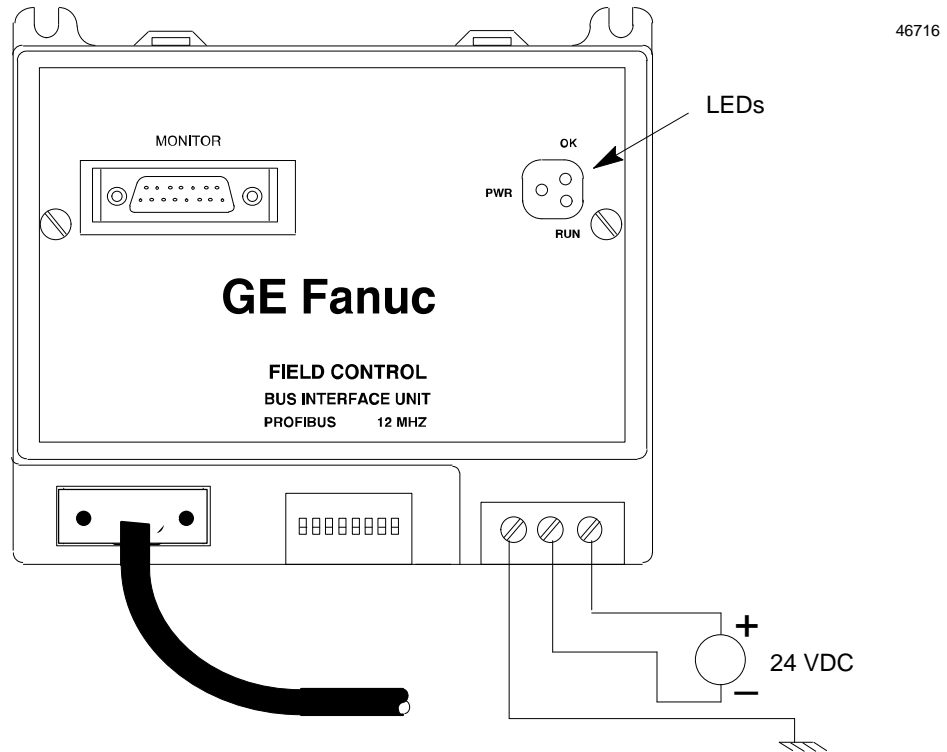

- PWR** – This LED is on when the BIU is receiving power.
- OK** – Shows the status of the BIU. This LED blinks during power-up diagnostics and should remain on as long as power is applied to the BIU. See the table below for more information.
- RUN** – Shows whether the BIU is actively receiving outputs from the network. See the table below.

OK	RUN	Meaning
ON	ON	Module functioning, CPU communicating
ON	OFF	Module functioning, no Profibus Master activity for the time set into the Set_Prm by the master. This watchdog time can be disabled by the master. If it is disabled, the RUN LED does not turn OFF when the master stops I/O exchange.
ON	Blinking	Module functioning, circuit forced
Blinking	ON	Circuit fault, CPU communicating
Blinking	OFF	Circuit fault, no Profibus Master activity for the time set into the Set_Prm by the master. This watchdog time can be disabled by the master. If it is disabled, the RUN LED does not turn OFF when the master stops I/O exchange.
Alternate Blinking		Circuit fault, Circuit forced
Synchronous Blinking		BIU is in boot mode
OFF	Blinking	Electronics/terminal Assembly mismatch
OFF	OFF	No block power, or Block faulty

Removing/Replacing the Bus Interface Unit Fuse

If all the Bus Interface Unit LEDs go off, it may be necessary to replace its fuse. The fuse can be removed without disturbing any other parts of the station or wiring.

To check the fuse, remove power from the station.

Fully loosen the retaining screws in the Bus Interface Unit and carefully remove it from the Terminal Block. Do not tilt the module during removal.

Caution

Avoid touching the exposed wiring on the Terminal Block when removing the Bus Interface Unit.

Caution

Electrostatic discharge can damage the module when it is not installed on a Terminal Block. Always observe normal ESD protection practices (for example, use a grounding strap) when handling an un-installed module.

The fuse location is shown below. Visually inspect the fuse to see whether it has blown.

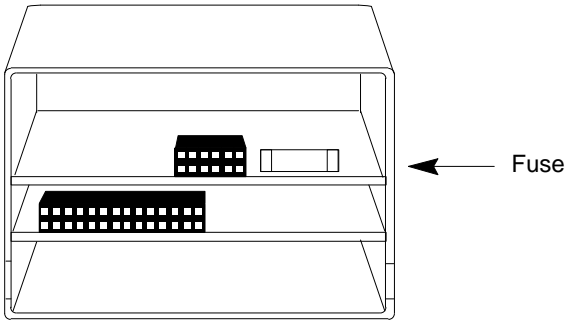

To remove the fuse from the holder, carefully pry it upward. Take care not to damage any components in the module. Place the new fuse in position and press it into the holder.

The fuse should be a 1A, 5x20mm 250VAC slow-blow type.

Reinstall the Bus Interface Unit on the BIU Terminal Block.

Removing the Bus Interface Unit Terminal Block

1. Loosen the clamp screw.
2. Remove the panel-mounting screws.
3. Insert a small flat-blade screwdriver into the upper latch and pry it outward. Then, pull up gently on the top of the terminal block to disengage the upper latch from the rail.

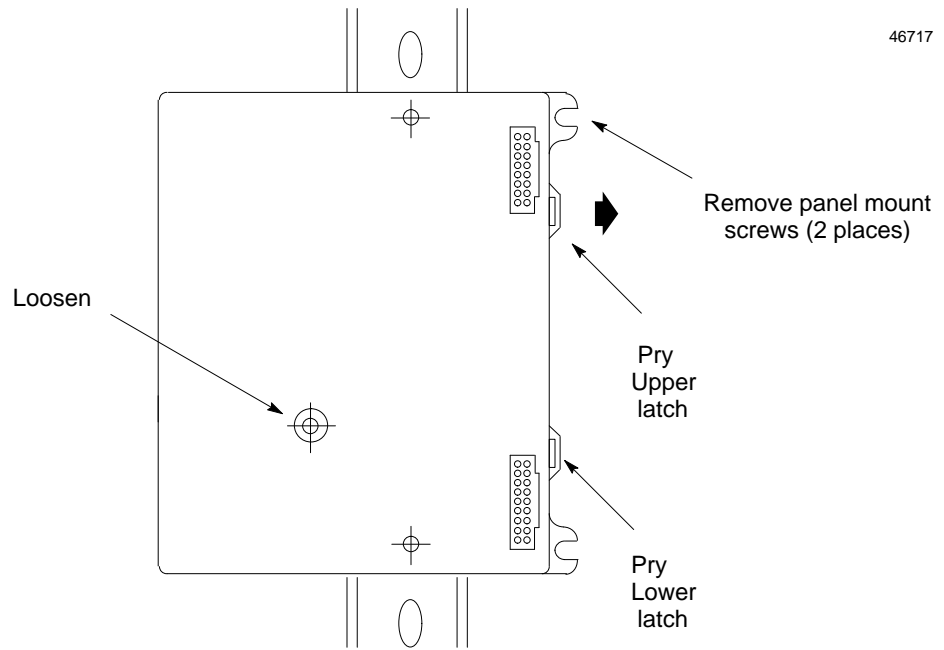

4. Keep gently pulling the top of the terminal block away from the rail. Insert the screwdriver into the lower latch and pry it outward to free the terminal block.

Upgrading the BIU Firmware

The BIU firmware can be upgraded from an IBM PC (or compatible) computer.

You will need the following equipment:

- A special cable and RS232/422 converter to connect the computer's COM1 port to the Monitor connector on the Profibus BIU. This can be either of the following (A or B):
 - A. Cable/converter IC690ACC901.
 - B. Converter IC690ACC900, used with cable IC690CBL303 plus either of the following cables:
 - 25-pin RS232 Serial Cable IC690CBL705
 - 9-pin RS232 Serial Cable IC690CBL702
- An IBM AT/PC compatible computer with at least 640K ram, one diskette drive, MSDOS 3.3 (or higher), and one RS232 serial port.

If the computer's COM1 port is not a 9-pin serial port, an adapter can be used if necessary.

If the COM1 port is not available, the PC Loader program can be adapted to work with other COM ports. Contact GE Fanuc PLC Technical Support for information.

- (Recommended) a hard drive with at least 1 Megabyte of available space.
- The firmware upgrade diskette. The diskette also includes PC Loader software and an installation program. The PC Loader utility controls downloading the new firmware from the floppy to the FLASH memory of the BIU.

Upgrade Instructions

1. Connect the cable/converter (as listed above) from the computer's COM port to the Monitor connector on the BIU.
2. Insert the upgrade diskette into the computer's diskette drive (A or B).

If the computer has a hard disk, at the DOS prompt (C:\>), type A:install (or B:install if the diskette is in drive B). The PC Loader program is copied to the computer's hard drive. It is automatically deleted after the download is complete.

Install can also be run from the floppy drive directly if there is no hard drive or not enough space on the hard drive. To run from the diskette, change the working directory to point to the drive where the Install diskette is inserted and type INSTALL (carriage return).

3. DO NOT CHANGE THE BAUD RATE NOW. Press the F3 key to change the communications port used by the PC. The Tab key toggles the port selection between COM1 and COM2. (The default is COM1)
4. From the main menu, press the F1 key to attach to the slave device (the BIU).
5. Once the BIU is attached, the boot mode menu appears – press F1 to enter BOOT MODE and press the 'Y' key to confirm the operation.
6. Once in boot mode, a new menu appears where the baud rate can be changed from the default rate of 19200 if desired. To change the baud rate, press the F2 key. Press

the TAB key to toggle through the supported baud rates then press the ENTER key to change the baud rates of both the master (PC) and the slave.

7. When the baud rate change operation is complete, press the F1 key to download the new firmware.
8. Press the 'Y' key to confirm the operation. The download will take several minutes. Download time is approximately 5 minutes at 19200 baud. If the download fails, refer to *Restarting An Interrupted Firmware Upgrade*.
9. When the download is complete, the PC loader will instruct you to power cycle your module. At this time, power cycle the BIU.

Restarting an Interrupted Firmware Upgrade

1. Connect all cables as described above.
2. Power cycle the BIU.
3. Follow steps 2 through 4 above.
4. If the update still fails, repeat the process with a lower baud rate.
5. Place the upgrade label supplied with the diskette next to existing product label.

Chapter 3

Autoconfiguration

At powerup, a new Profibus Bus Interface Unit can automatically configure the operation of the I/O Station and start exchanging I/O and diagnostics data with the master.

Autoconfiguration can also be done using a Hand-held Programmer.

This chapter explains the features of Autoconfiguration.

- Description
- Input and Output References Assigned by Autoconfiguration
- Default Module Features Selected by Autoconfiguration
- Hand-held Programmer Settings for Autoconfiguration
- Autoconfiguration from a Hand-held Programmer
- Notes about Adding and Deleting Module Configurations

For Additional Information, Also See:

Chapter 4, *Using a Hand-held Programmer*.

Description

During Autoconfiguration, the BIU automatically reads the configuration of the I/O modules that are presently installed. The BIU generates a configuration for the I/O Station which it stores in the BIU Terminal Block.

The BIU configures modules slot-by-slot, starting with slot one. It continues to slot eight or the first empty slot.

Autoconfiguration assigns I/O memory to each module and uses the module's default configuration.

The configuration can be edited using a Hand-held Programmer. This must be done in any of the following cases:

- There is a module installed after an empty slot.
- A module must be deleted after configuration.
- A different type of module is installed in a slot after configuration.
- A module's default features need to be changed.

Default Module Features Selected by Autoconfiguration

Autoconfigured I/O modules use the following settings (these can be changed manually):

Module Type	Feature	Configured for:	Default
Discrete Input	Report Faults	module	yes
	Hold Last State	circuits	no
Discrete Output	Hold Last State	circuits	no
	Output Default States	circuits	0
	Report Faults	module	yes
Analog Input	Report Faults	channels	yes
	Channel Active	channels	yes
	Range	channels	0-20mA
	Scaling Units : engineering units integer units	channels	low=00000 high=20000 low=00000 high=20000
	Alarm limits	channels	low=00000 high=*
	Hold Last State	module	no
Analog Output	Hold Last State	module	no
	Output Default States	channels	00000
	Report Faults	channels	yes
	Channel Active	channels	yes
	Range	channels	0-20mA
	Scaling Units : engineering units integer units	channels	low=00000 high=*\br/>low=00000 high=*

* Default value depends on module type.

Input and Output References Assigned by Autoconfiguration

During Autoconfiguration, a BIU assigns the modules in its I/O Station to reference addresses within its own memory tables. References start at 0001 within each memory type.

- Discrete Inputs Begin at I00001 (bit data)
- Discrete Outputs Begin at Q00001 (bit data)
- Analog Inputs Begin at AI0001 (word data)
- Analog Outputs Begin at AQ0001 (word data)

These reference addresses are used locally by the BIU and are also used when looking at I/O data with a Hand-held Programmer (for example, when forcing I/O data)..

Example Configuration #1: Discrete Input and Output Modules

The first example configuration shows how the BIU assigns references to a group of discrete input and output modules that are present when it is powered up.

Slot 0	Bus Interface Unit	none
Slot 1	Relay Output module (8 points)	Q00001 – Q00008
Slot 2	ESCP Output module (8 points)	Q00009 – Q00016
Slot 3	Discrete Output module (16 points)	Q00017 – Q00032
Slot 4	Discrete Output module (16 points)	Q00033 – Q00048
Slot 5	Discrete Input module (16 points)	I00001 – I00016
Slot 6	ESCP Output module (8 points)	Q00049 – Q00064
Slot 7	Discrete Input module (16 points)	I00017 – I00032
Slot 8	Discrete Input module (16 points)	I00033 – I00048

Example Configuration #2: Discrete Modules, Empty Slot Between Modules

Autoconfiguration by the BIU stops at the first empty slot.

This example shows the same modules as example configuration #1, but the module in slot 7 is not present when the BIU is powered up. Therefore, the module in slot 8 is not included in the configuration (it can be configured manually).

Slot 0	Bus Interface Unit	none
Slot 1	Relay Output module (8 points)	Q00001 – Q00008
Slot 2	ESCP Output module (8 points)	Q00009 – Q00016
Slot 3	Discrete Output module (16 points)	Q00017 – Q00032
Slot 4	Discrete Output module (16 points)	Q00033 – Q00048
Slot 5	Discrete Input module (16 points)	I00001 – I00016
Slot 6	ESCP Output module (8 points)	Q00049 – Q00064
Slot 7	Empty	
Slot 8	Discrete Input module (16 points)	<u>not configured</u>

Example Configuration #3: Discrete and Analog Input and Output Modules

The BIU autoconfigures analog modules in the same way as discrete modules. Each analog reference address represents one word of memory. (Each discrete reference represents one bit of memory).

Slot 0	Bus Interface Unit	none
Slot 1	Analog Input module (8 points)	AI0001 – AI0008
Slot 2	ESCP Output module (8 points)	Q00001 – Q00008
Slot 3	Discrete Output module (16 points)	Q00009 – Q00024
Slot 4	Analog Output module (4 points)	AQ0001 – AQ0004
Slot 5	Discrete Input module (16 points)	I00001 – I00016
Slot 6	ESCP Output module (8 points)	Q00025 – Q00032
Slot 7	Discrete Input module (16 points)	I00017 – I00032
Slot 8	Analog Output module (4 points)	AQ0005 – AQ0008

Hand-held Programmer Settings for Autoconfiguration

A new Profibus is already set up to perform Autoconfiguration when it is powered up. No Hand-held Programmer is needed for Autoconfiguration.

However, a Hand-held Programmer can control Autoconfiguration in two ways:

- Autoconfiguration can be disabled (or re-enabled) with a Hand-held Programmer.

Auto Config
Disabled

Manually changing the BIU's I/O map or manually configuring any slot automatically disables Autoconfiguration.

- Both Autoconfiguration and manual configuration (done with a Hand-held Programmer) can be prevented by turning on Configuration Protection.

Config Protect
Enabled

Autoconfiguration with a Hand-Held Programmer

Autoconfiguration can also be done using a Hand-held Programmer, from the Auto Configenable/ disabled display:

Auto Config
Disabled

Pressing the Toggle key toggles the state of Autoconfiguration. When the state is toggled from disabled to enabled, the following screen appears:

Do New Config!
Are you sure?

Pressing the ENT key deletes the current configuration and autoconfigures the currently-installed modules. If the CLR key is pressed, no Autoconfiguration is performed.

Notes about Adding and Deleting Modules

Adding Modules	Autoconfiguration will only add modules to the BIU configuration. It will never delete an individual module.
Deleting Modules	Individual modules must be deleted manually.
Deleting I/O Station	An entire I/O Station configuration can be deleted by powering up the BIU with NO modules present in the Field Control bases.

Messages Resulting from Adding or Deleting Modules

- For each module added by Autoconfiguration, an *Addition of I/O Module* fault is generated.
- For each module that was previously configured which is no longer present, Autoconfiguration generates a *Loss of I/O Module* fault. However, the slot remains configured for the absent module.
- If a slot has been configured for one module type but has a different module installed when Autoconfiguration is performed, a *Configuration Mismatch* error is generated. However, the slot remains configured for the original module type.
- If there is an unconfigured module present after an empty slot, the module is not configured and an *Extra I/O Module* fault is generated.

Chapter 4

Instructions for Using a Hand-held Programmer

This chapter explains how to use a Hand-held Programmer with a Profibus BIU:

- Getting Started
- Displaying and Editing BIU Configuration Data
- Performing and Disabling Autoconfiguration
- Enabling or Disabling I/O Scanning
- Configuring the BIU Manually
- Configuring I/O Modules Manually
- Monitoring and Forcing I/O Data
- Displaying and Clearing Faults with the HHP

For Additional Information, Also See:

For additional information on basic Hand-held Programmer functions, please refer to the *Hand-held Programmer User's Manual* (GFK-0402).

Getting Started

Attach the Hand-held Programmer to the MONITOR connector on the BIU.

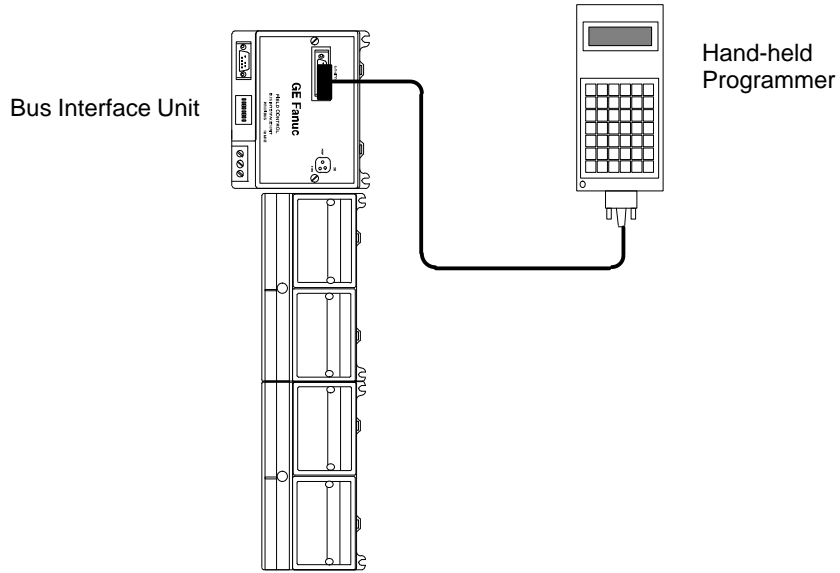

46718

HHP Displays

This is the HHP's main menu for a Profibus Bus Interface Unit:

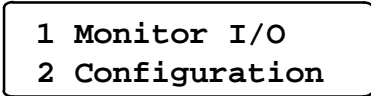

Menu Overview

The illustration below shows the primary Hand-held Programmer menus that are accessed from the Profibus BIU main menu.

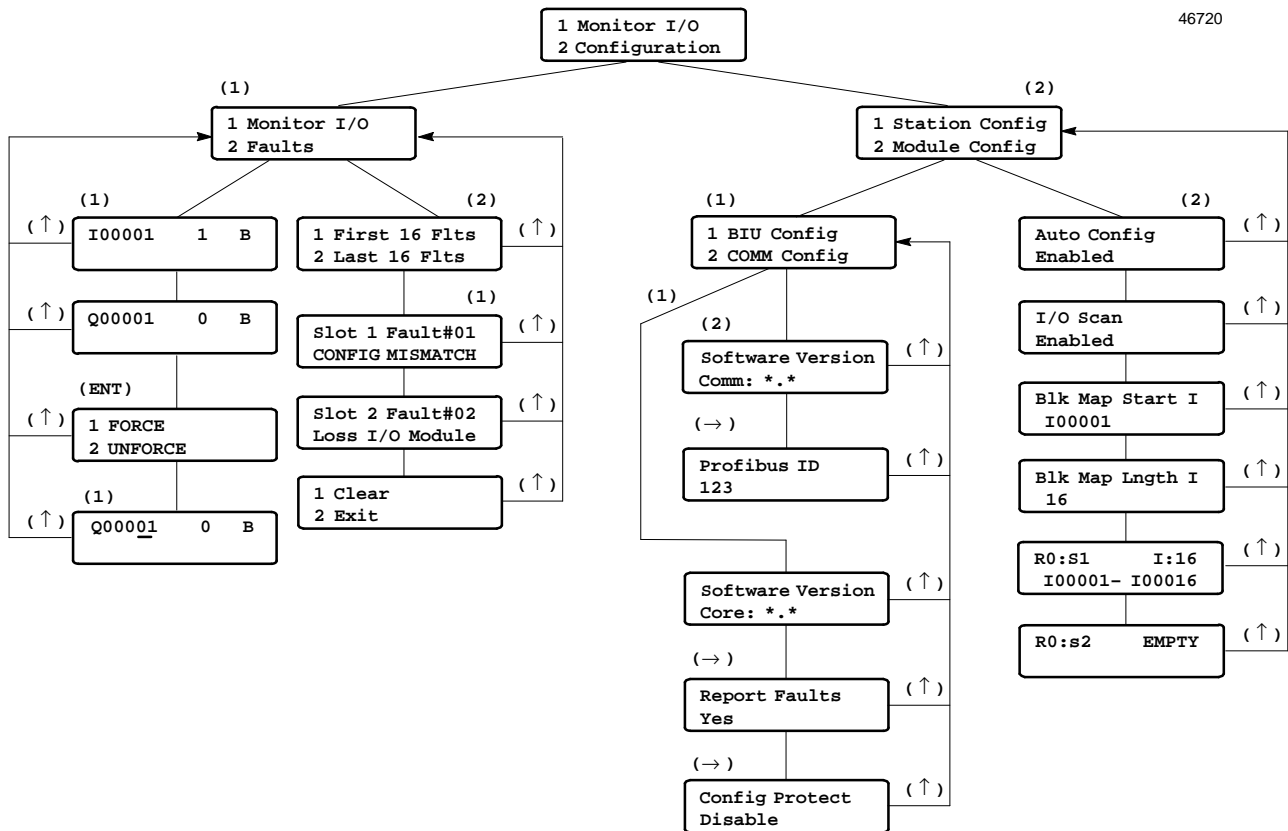

Moving from Screen to Screen

To move between displays, use the following keys:

- ➡ press the Right Arrow key to go to the next screen.
- ➡ press the Left Arrow key to go to the previous screen.
- ⬆ press the Up Arrow key to return to the previous level.

Displaying and Editing BIU Configuration Data

From the main menu, press the **2** key (Configuration). This menu appears:

```
1 Station Config
2 Module Config
```

All configurations, whether automatic or manual, are stored in EEPROM and are retained through a power cycle.

From this menu, you can:

- Press the **1** key to display and change, the station configuration.
- Press the **2** key to enter, display, and edit I/O module configurations.

Displaying or Changing the Station Configuration

To view or change the BIU configuration, press the **1** key from the Station Config/Module Config screen.

```
1 Monitor I/O
2 Configuration
```

(2)

```
1 Station Config
2 Module Config
```

(1)

```
1 BIU Config
2 COMM Config
```

(1)

```
Software Version
Core: *.*
```

```
Report Faults
Yes
```

```
Config Protect
Disable
```

```
1 BIU Config
2 Comm Config
```

Display the BIU Core Software Version

When you select BIU Configuration menu, the first BIU configuration display screen appears. This screen shows the version of the BIU's core software.

```
Software Version
Core: *.*
```

Press the Right Arrow key to go to the next screen.

Enable or Disable Fault Reporting

The next screen can be used to enable or disable fault reports from the Profibus BIU on the bus.

```
Report Faults
YES
```

You can change the configuration of fault reporting using the Toggle key then the ENT key. To go to the next screen, press the Right Arrow key.

Enable or Disable Configuration Protection

This feature can be used to protect the station configuration. To make subsequent changes, protection must be removed again. Before the station is used, its configuration should be protected.

Config Protect
Disabled

By default, Configuration Protection is disabled. You can change Configuration Protection using the Toggle key then the ENT key.

Note that toggling the state of Configuration Protection does not cause Autoconfiguration to be performed if the Autoconfiguration feature is enabled.

Displaying the BIU Communications Software Version

When you select Comm Configuration menu, the first Comm configuration display screen appears. This screen shows the version of the BIU communications software.

1 Monitor I/O
2 Configuration

(2)

1 Station Config
2 Module Config

(1)

1 BIU Config
2 COMM Config

(2)

Software Version
Comm: *.*

Profibus ID
123

Software Version
Comm: *.*

Press the Right Arrow key to go to the next screen.

Displaying or Changing the Bus ID

To view or change the Profibus configuration, press the Right Arrow key from the BIU software version screen.

Profibus ID
45

Note

The Profibus ID can be changed any time. However, the selected ID will not be used until the BIU is power-cycled with DIP switch 8 set to zero.

If you want to change the Profibus ID, enter a new number from the keypad then press the ENT key.

To return to the Station Configuration screen, press the Up Arrow key.

Performing and Disabling Autoconfiguration

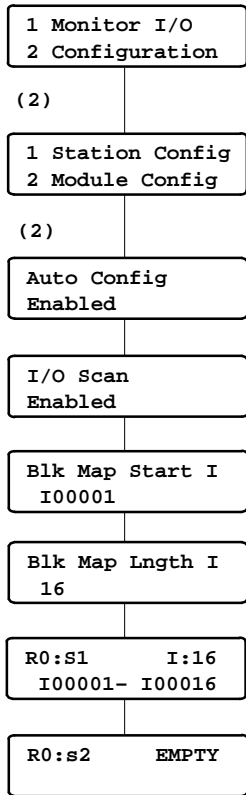

Enabling Autoconfiguration causes the BIU to automatically generate configuration data based on the modules currently present in the station. Autoconfiguration can also be performed from a Hand-held Programmer. For more information about Autoconfiguration, see chapter 3.

Autoconfiguration can be disabled with the Hand-held Programmer. Configuration Protection can be set to prevent all configuration changes, both automatic and manual. Configuration Protection must be disabled for Autoconfiguration to be performed.

Disabling Autoconfiguration

The default state of Autoconfiguration is enabled. To prevent Autoconfiguration, press the 2 key from the Station Config/Module Config menu. The Autoconfiguration screen appears.



You can disable Autoconfiguration using the Toggle key followed by the ENT key.

Performing Autoconfiguration from the Hand-held Programmer

Autoconfiguration is executed with the Hand-held Programmer from the Autoconfiguration enabled/disabled display:



Toggling the state of Autoconfiguration from disabled to enabled then pressing the ENT key causes Autoconfiguration to occur.

When the state is toggled to enabled, the HHP prompts:



If you press the ENT key, the existing configuration is deleted and installed modules are autoconfigured. (This deletes the entire configuration, including any selections made manually). To quit without autoconfiguring, press the CLR key instead.

Configuration Protection

Configuration Protection must be disabled for Autoconfiguration. If the Configuration Protection feature is enabled, toggling Autoconfiguration has no effect.

Note

If Autoconfiguration is enabled while Configuration Protection is enabled, toggling the state of Configuration Protection does not cause Autoconfiguration to be performed. Disable Configuration Protection, then go to the Autoconfiguration screen and toggle the state of Autoconfiguration to autoconfigure the BIU.

Enabling or Disabling I/O Scanning

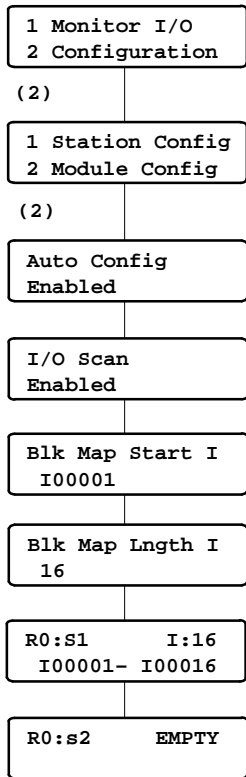

During normal operation of the Profibus BIU, I/O scanning is enabled. With I/O scanning enabled, the BIU scans the I/O modules and exchanges I/O data with the master via the Profibus. I/O scanning can be disabled for special circumstances when it was necessary to shut down the station.

If I/O scanning is disabled, the BIU stops reading inputs and sets outputs to their individually-configured defaults.

The I/O Scan enable/disable screen of the Hand-held Programmer is located after the Auto Configuration screen as shown at left.

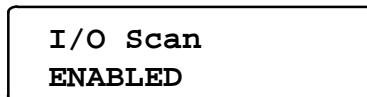

You can disable (or enable) I/O scanning by using the Toggle key followed by the ENT key.

Configuring the BIU Manually

Manual configuration can be used to assign features to the BIU and to the modules in the I/O station. It can be used in addition to or instead of Autoconfiguration. Manual configuration is necessary if:

- You want to change the default features.
- You want to configure modules that are not present.
- There is an empty slot between modules in the I/O Station. Autoconfiguration stops at the first empty slot. Modules after the empty slot must be configured manually.

Configuring the BIU's Network I/O Map

The Bus Interface Unit's network (bus) I/O map defines the BIU memory addresses used for the data that will be exchanged on the bus. These addresses are used only by the BIU (they are not meaningful to the host).

I/O module data assigned to addresses within this I/O map will be exchanged on the bus. I/O data assigned to addresses outside the I/O map will not be exchanged on the bus. Note that the steps described below define only the BIU's I/O map. Individual I/O module addresses are assigned separately, either by autoconfiguration or manual configuration.

The following table shows the maximum amount of each data type that may be configured in the BIU's I/O map, and the highest reference address available for each type. The maximum amount of input data (discrete + analog) is 128 bytes.

BIU Memory Type	Used For	Maximum Length for BIU I/O Map	Highest Available Reference Address
I	discreteinputs	up to 1024 contiguous bits	32767
Q	discreteoutputs	up to 1024 contiguous bits	32767
AI	analoginputs	up to 64 contiguous words	9999
AQ	analogoutputs	up to 64 contiguous words	9999

1. Enter a starting address for I data. Press the ENT key to accept the address and continue.

```

Blk Map Start I
I00001
    
```

2. Enter a length in bits for the I data. For example:

```

Blk Map Lngth I
16
    
```

3. Press the ENT key to accept the length.
4. Continue as above, entering starting addresses and lengths for the other data types. Lengths for AI and AQ are 16-bit words.

The lengths entered must not add up to more than 128 bytes of inputs (discrete + analog) and 128 bytes of outputs (discrete + analog).

The lengths selected should include all the I/O data that will be exchanged on the bus. If a data length is too short, modules that overflow the configured limit will not be serviced by the main CPU system.

Any I/O modules (*or portions of modules*) configured outside the I/O map will be scanned by the Bus Interface Unit, but the data will not be exchanged on the bus.

You might use a worksheet like the one shown below to record the I/O references configured for the Bus Interface Unit and for the modules in the I/O Station. Slot 0 is the location of the BIU. Slots 1 through 8 (maximum) contain I/O modules.

Module References and Reference Parameters Worksheet

Slot #	Module Type	Memory Type	References Used	Data Type	Length
0	Bus Interface Unit	I		bits	
	(These references are the ones transferred on the bus).	Q		bits	
		AI		2-byte words	
		AQ		2-byte words	
1		I		bits	
		Q		bits	
		AI		2-byte words	
		AQ		2-byte words	
2		I		bits	
		Q		bits	
		AI		2-byte words	
		AQ		2-byte words	
3		I		bits	
		Q		bits	
		AI		2-byte words	
		AQ		2-byte words	
4		I		bits	
		Q		bits	
		AI		2-byte words	
		AQ		2-byte words	
5		I		bits	
		Q		bits	
		AI		2-byte words	
		AQ		2-byte words	
6		I		bits	
		Q		bits	
		AI		2-byte words	
		AQ		2-byte words	
7		I		bits	
		Q		bits	
		AI		2-byte words	
		AQ		2-byte words	
8		I		bits	
		Q		bits	
		AI		2-byte words	
		AQ		2-byte words	

Configuring I/O Modules Manually

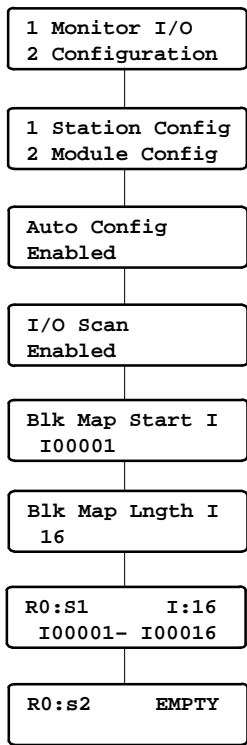

I/O modules can be configured manually if they are not present for Autoconfiguration or if they will not use the default features (see the table on page 3-2). In addition, if there is an empty slot in the I/O Station, any module located after that slot must be configured manually.

The module configuration screens are located following the BIU I/O map configuration screens as shown at left.

If there is a module present in the slot, the module configuration screen looks like this:

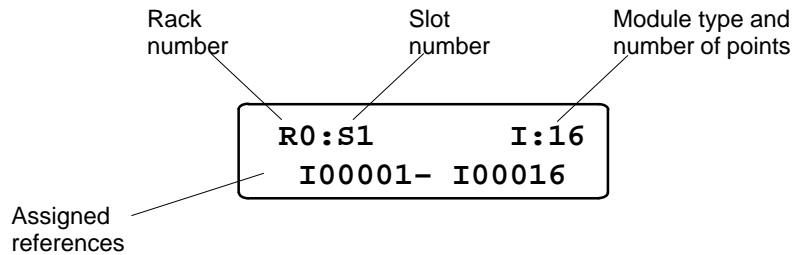

The **Rack Number** is always 0 for Field Control.

The **Slot Number** refers to the location of the module in the station, relative to the Bus Interface Unit.

Specify the I/O reference addresses to be used by the module. For most applications, you can simply have the Bus Interface Unit assign the next available addresses in that memory type. Or you can enter specific addresses for the module as described in the individual module configuration pages.

For the present version of the Profibus BIU, all module reference addresses should fall within the network map configured for the BIU.

In addition, input data and output data (discrete plus analog) each have a total of 256 bytes allocated within the BIU.

In the example screen illustrated above, the Bus Interface Unit assigns 16 reference addresses beginning at I00001 to a 16-point input module. In the same system, the next discrete input module in the station would automatically be assigned references beginning at I00017.

It is not necessary to assign a new reference address to I/O modules. However, if you have removed a configured module you may wish to re-assign its references to another module on the new module's configuration screens. (The HHP will not automatically go back and re-use references after a module is deleted.)

From this screen, you can:

- Display other modules using the Right Arrow and Left Arrow key.
- Delete the currently-displayed module by pressing the **DEL** key.
- Configure the current module by pressing the Down Arrow key.

Refer to the configuration instructions on the following pages for more information.

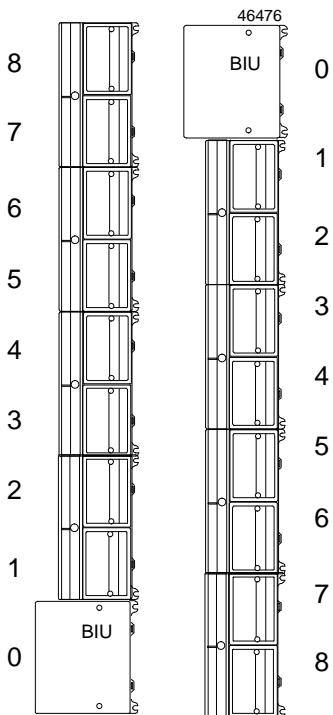

Reading a Module Configuration

If there is an unconfigured module present in the slot, press the **READ** key to read its configuration. This brings up the module's identification screen. For example:

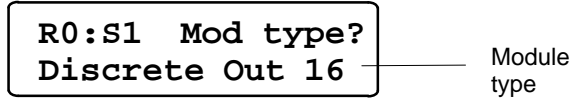

You can edit this configuration as described on the following pages.

Configuring an Empty Slot

If there is no module present in the slot, the screen displays:

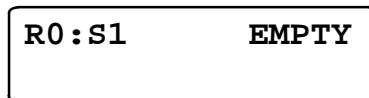

If you want to enter a configuration, press the Toggle key. This screen will appear:

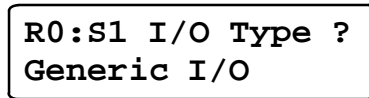

1. Press the Toggle key to select either Generic I/O or Special I/O (see the list below). Then press the ENT key..

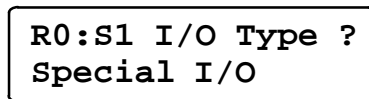

2. The screen prompts: **R0:S1 Mod Type ?** Use the Toggle key to go through the module names listed below.

GenericI/O	SpecialI/O
DiscreteInput4/8	Analog 8 Current Input
All 16-point Discrete Input modules	Analog 4 Current Output
DiscreteOutput4/8	Analog 8 Volt Differential Input
All 16-point Discrete Output modules	ESCP 8 Discrete Out

3. When the correct module name appears, press the **ENT** key. Complete the module configuration as described on the following pages.

Configuring a Discrete Input Module

Follow the steps below to configure a discrete input module.

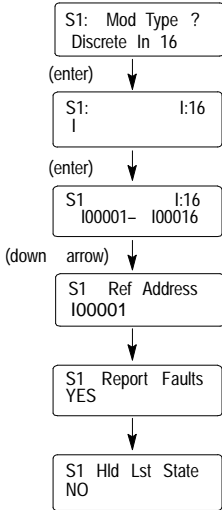

Module Reference Address

On the first configuration screen, the assigned module reference address appears. It is not necessary to enter a new address.

S1 Ref Address
I00001

1. Use the keypad if you want to enter a new address.

Module reference addresses must fall within the network map configured for the Bus Interface Unit to be sent to the master.
Input data (discrete plus analog) has a total of 256 bytes allocated within the BIU.

2. Use the **ENT** key to save the entry and go on.

Report Faults

If you press the Right Arrow key from the Reference Address screen, the following configuration screen appears:

S1 Report Faults
NO

The first line shows the module's slot number (**Slot 1** above) and the first configuration parameter, Fault Reporting. This parameter determines whether or not the Bus Interface Unit will report faults from the module to the host.

1. Select YES if the Bus Interface Unit should report module faults to the host. Select NO if it should not. Use the +/- key if you want to change the selection.
2. Use the **ENT** key to save the selection.

Default Inputs or Hold Last State

If you press the Right Arrow key from the Report Faults screen, the following configuration screen appears:

```
S1 Hld Lst State
NO
```

This parameter determines what type of data the Bus Interface Unit should provide to the host if it stops receiving actual input data from the module.

1. Select YES if the Bus Interface Unit should hold inputs in their last states and supply that data to the host.

Select NO if the Bus Interface Unit should default all the module's inputs to 0 and supply that data to the host instead.

2. Use the **ENT** key to save the selection.
3. Use the Right Arrow key from here to go to the original slot configuration screen.

Configuring a Discrete Output Module

Follow the steps below to configure a discrete output module.

Module Reference Address

On the first configuration screen, the assigned module reference address appears. It is not necessary to enter a new address.

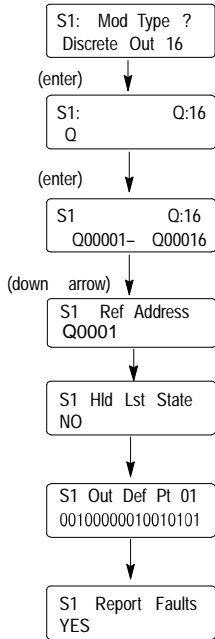

S1 Ref Address
Q00001

1. Use the keypad if you want to enter a new address.

Module reference addresses must fall within the network map configured for the Bus Interface Unit to be received from the master.

Output data (discrete plus analog) has a total of 256 bytes allocated within the BIU.

2. Use the **ENT** key to save the selection. Use the Right Arrow key to go to the next parameter.

Default Outputs or Hold Last State

The selection determines what type of data the Bus Interface Unit will provide to the module if it stops receiving actual output data from the host.

S2 Hld Lst State
NO

1. Use the +/- key if you want to change the selection.

Select YES if the Bus Interface Unit should hold outputs in their last states and supply that data to the module.

Select NO if the Bus Interface Unit should default all the module's outputs and supply that data to the module instead. **Note:** This has no effect if the BIU itself fails.

2. Use the **ENT** key to save the selection. If Hold Last State is set to NO, the following screen appears after a Right Arrow key is pressed:

S1 Out Def Pt 01
_0010000010010101

Number of the point
at the cursor location

3. On this screen, select a default state (1 or 0) for each output. To scroll between outputs use the Right and Left Arrow keys.
4. Use the **ENT** key to save the entries.
5. Press the Right Arrow key to go to the next parameter.

Report Faults

On the next screen, configure whether or not the Bus Interface Unit will report faults from this module to the host.

S2 Report Faults
NO

1. If you want to change the current selection, press the +/- key.
2. Use the ENT key to save the selection.
3. Use the Right Arrow key here to go back to the original slot configuration.

Configuring an Analog Input Module

Follow the steps below to configure an analog input module.

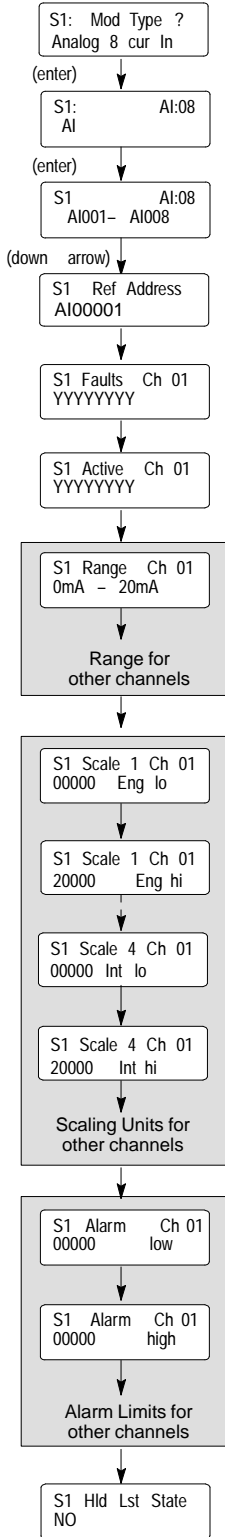

Module Reference Address

On the first configuration screen, the assigned module reference address appears. It is not necessary to enter a new address.

S1 Ref Address
AI0001

1. Use the keypad if you want to enter a new address.

Module reference addresses must fall within the network map configured for the Bus Interface Unit to be sent to the master.

Input data (discrete plus analog) has a total of 256 bytes allocated within the BIU.

2. Use the ENT key to save the selection and go on.
3. Use the Right Arrow key to go to the next parameter.

Fault Reporting

The Bus Interface Unit can report faults for each channel to the host. If fault reporting is enabled for a channel, the Bus Interface Unit sends a message to the host CPU if any fault occurs on that channel. If fault reporting is disabled, the Bus Interface Unit does not send fault reports for the channel to the host CPU.

Regardless of whether fault *reporting* is enabled, the Bus Interface Unit detects faults on the circuit and takes appropriate action. If a fault occurs, the fault condition must be corrected for proper operation of the I/O module.

S3 Faults Ch 01
NNYYYYYY

Number of the channel at the cursor location

1. For each channel, select Y if the Bus Interface Unit should report module faults to the host for that channel. Select N if it should not. Use the +/- key if you want to change the selection.
2. Use the Left Arrow and Right Arrow keys to select channels.
3. Use the ENT key to save the selections on this screen.
4. Use the Right Arrow key from the last channel to go to the next parameter.

Channel Active

When a channel is configured as Active, it is scanned for data and checked for errors. If a channel should not be scanned, that channel can be configured as inactive. An inactive input channel returns no faults and no data.

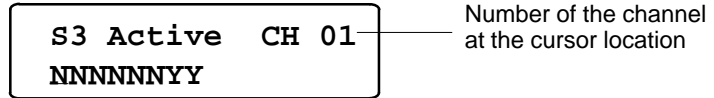

1. For each channel, select Y if the channel should be active. Select N if it should not.
2. Use the Left Arrow and Right Arrow keys to select channels.
3. Use the ENT key to save the selections on this screen.
4. Use the Right Arrow key from the last channel to go to the next parameter.

Input Current Ranges

Select a current range for each channel, to correspond to the signal level of the input device. Note that Current Source Analog Input Module (IC670ALG230) and Current Source Analog Output Module (IC670ALG320) cannot be used with negative voltages.

- 0 to 20mA
- 4 to 20 mA

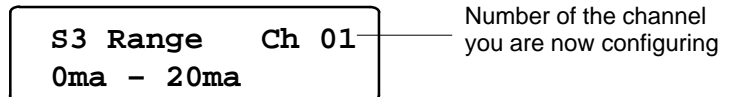

1. For each channel, use the +/- key to select a range.
2. Repeat this step for each of the eight channels, using the Left Arrow and Right Arrow keys to select channels.
3. Use the ENT key to save the selections on this screen and go on to the next item.
4. Use the Right Arrow key from the last channel to go to the next parameter.

Note

Range Selection is a setup parameter; it is not ordinarily changed while the module is operating.

Input Scaling

Based on the actual analog input signal level for a channel, the analog input module reports a value from decimal 0 to 4095 to the Bus Interface Unit. The Bus Interface Unit can convert this digital input to a value that is more meaningful to the application by using the “scaling values” configured on this screen.

For each channel, two sets of values are configured: high and low “scaled” values and the actual high and low digital values they represent. Based on these two pairs of values, the Bus Interface Unit will be able to scale values for all other input levels.

See the *Field Control I/O Modules User’s Manual* (GFK-0826) for information on finding appropriate scaling values for your application. If you don’t have scaling values ready, you can continue to the next screen now, and configure scaling at another time. The Bus Interface Unit will use default scaling values of 1:1 if no scaling values are entered.

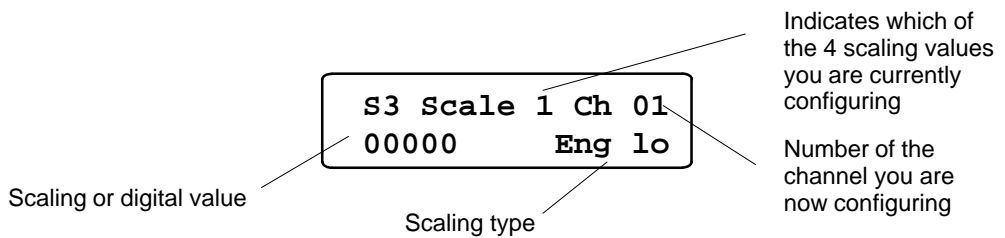

1. For EACH channel in turn, enter scaling values in this order:

- Low scaling value (“eng lo”)
- High scaling value (“eng hi”)
- Low digital value (“int lo”)
- High digital value (“int hi”)

2. If you press the Right Arrow key, the display goes from value to value in sequence. If you press the Left Arrow key, the display goes to the first value for the previous channel.
3. Use the HHP keypad to enter values. To enter a negative value, first enter the numbers, then press the - key.
4. Use the ENT key to save the selections on this screen and go to the next item.
5. From the last scaling screen, press the Right Arrow key to go to the next parameter.

Alarm Thresholds

Each input channel can have two Alarm Thresholds, one for a low engineering units (scaled) value and one for a high value.

Maximum values are " 32,767. The high threshold should be greater than the low threshold. Threshold limits are based on circuit scaling. If scaling is changed, review and readjust the Alarm Thresholds if necessary.

Alarm Thresholds can be set anywhere over the dynamic range of the signal. Typically, they are set at levels beyond which the input should not operate or levels beyond which alternate processing is required. They can also be set beyond the dynamic range of the signal, ensuring that they will never be activated. See the examples on the next page.

1. For EACH channel in turn, first, enter a low alarm value.

```
S3 Alarm Ch 01
00000 low
```

Number of the channel you are now configuring

2. Press the **ENT** key. Press the Right Arrow key to go to the High Alarm screen. The actual default high value depends on the module type.

```
S3 Alarm Ch 01
00000 high
```

3. Enter a high alarm value.
4. Use the Arrow keys to select channels.
5. Press the **ENT** key to save the selection. Press the Right Arrow key to return to the original slot configuration screen.

Example 1: A circuit is expected to report engineering unit values of -20 ft/sec (-6 m/sec) to +180 ft/sec (+50 m/sec). The high alarm is set at 150 ft/sec (+40 m/sec) and the low alarm at -25ft/sec(-7.5m/sec).

If an input reached its high alarm, a new threshold could be set dynamically. This could generate a high-high alarm or an alarm-cleared threshold.

Example 2: An Alarm Threshold is set at 150 ft/sec. Upon receiving an alarm message, the CPU changes the Alarm Threshold to 165 ft/sec by using a Write Configuration command and sends the appropriate Clear Circuit Fault command. No alarm message is sent upon changing the threshold unless the speed is greater than 165 ft/sec. If the speed is only 157 ft/sec but increasing, a second message would be sent at 165 ft/sec. Since these two diagnostic messages are the same, it would be necessary for the program to keep track of the level of the Alarm Thresholds and recognize this as a higher alarm than that received initially. At the same time, it could move the low alarm to 140 ft/sec and use this level to detect the end of the high alarm conditions.

Default Inputs or Hold Last Values

First, configure what type of data the Bus Interface Unit should provide to the host if it stops receiving actual input data from the module.

```
S3 Hld Lst State
NO
```

1. Use the +/- key if you want to change the selection.
 Select YES if the Bus Interface Unit should hold inputs in their last states and supply that data to the host.
 Select NO if the Bus Interface Unit should default all the module's inputs to 0 and supply that data to the host instead.
2. Use the **ENT** key to save the entry.
3. Use the Right Arrow key from here to go to the original slot configuration screen.

Configuring an Analog Output Module

Follow the steps below to configure an analog output module.

Module Reference Address

On the first configuration screen, the assigned module reference address appears. It is not necessary to enter a new address.

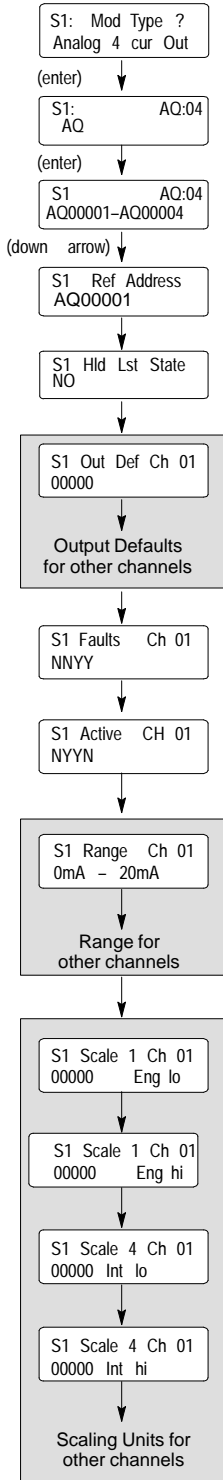

S1 Ref Address
AQ0001

1. Use the keypad if you want to enter a new address.

Module reference addresses must fall within the network map configured for the Bus Interface Unit to be received from the master.

Output data (discrete plus analog) has a total of 256 bytes allocated within the BIU.

2. Use the ENT key to save the selection.
3. Use the Right Arrow key to go to the next parameter.

Default Outputs or Hold Last Values

Next, configure what type of data the Bus Interface Unit should provide to the module if it stops receiving actual output data from the host.

S4 Hld Lst State
NO

1. Select YES if the Bus Interface Unit should hold outputs in their last states and supply that data to the module.
Select NO if the Bus Interface Unit should default all the module's outputs and supply that data to the module instead.
2. Press ENT to save the selection.
3. Use the Right Arrow key to go to the next parameter.

Fault Reporting

The Bus Interface Unit can report faults for each channel to the host. If fault reporting is enabled for a channel, the Bus Interface Unit sends a message to the host CPU if any fault occurs on that channel. If fault reporting is disabled, the Bus Interface Unit does not send fault reports for the channel to the host CPU.

Regardless of whether fault *reporting* is enabled, the Bus Interface Unit detects faults on the circuit and takes appropriate action. If a fault occurs, the fault condition must be corrected for proper operation of the I/O module.

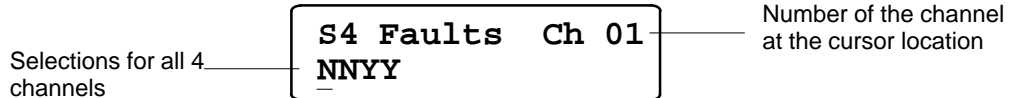

1. Use the +/- key to select Y or N for each channel. Select Y if the Bus Interface Unit should report module faults to the host for that channel. Select N if it should not.
2. Use the Arrow keys to select channels. If Hold Last State is set to NO, pressing the Left Arrow key from the first channel displays the Output Default screen.
3. From the last channel, press the Right Arrow key to go to the next parameter.

Channel Active

If a channel is configured as active, it will be scanned for data and checked for errors. If a channel should be ignored, configure that channel as inactive.

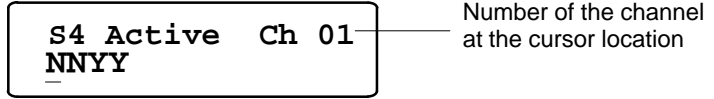

1. For each channel, select Y if the channel should be active. Select N if it should not.
2. Use the Left Arrow and Right Arrow keys to select channels.
3. Use the ENT key to save the selections on this screen.
4. Use the Right Arrow key to go to the next parameter.

Output Current Ranges

Select the current range for each channel to correspond to the signal level of the output device. Note that Current Source Analog Output Module (IC670ALG320) can only be set for 0 to 20mA or 4 to 20mA.

- 0 to 20mA
- 4 to 20 mA

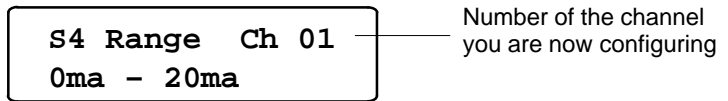

1. For each channel, use the +/- key to select a range.
2. Repeat this step for each of the eight channels, using the Left Arrow and Right Arrow keys to select channels.
3. Use the ENT key to save the selections on this screen.

Note

Range Selection is a setup parameter; it is not ordinarily changed while the module is operating.

4. Use the Right Arrow key to go to the next parameter.

Output Scaling

While the actual values received from the application program may represent various types of engineering units, the Bus Interface Unit reports values from decimal 0 to 4095 to an analog output module. The BIU converts the application data into internal units using “scaling values”. These internal values are then converted to counts and sent to the output channels.

For each channel, two sets of values are configured: high and low internal values and the actual high and low engineering units values they represent. Based on these two pairs of values, the Bus Interface Unit will be able to scale values for all other output levels.

See the *Field Control I/O Modules User’s Manual* (GFK-0826) for information on finding appropriate scaling values for your application. If you don’t have scaling values ready, you can continue to the next screen now and configure scaling at another time. The Bus Interface Unit will use default scaling values of 1:1 if no scaling values are entered.

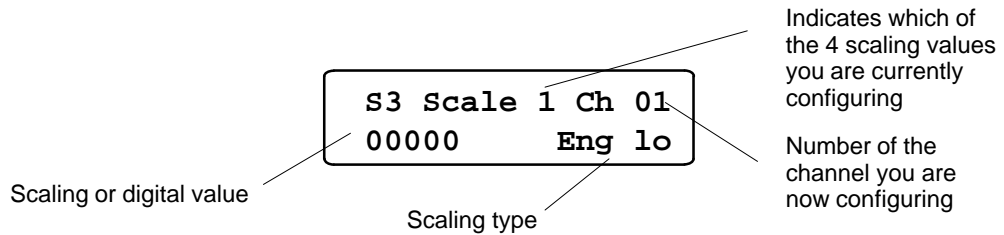

1. For EACH channel in turn, enter scaling values in this order:

- Low scaling value (“eng lo”)
- High scaling value (“eng hi”)
- Low digital value (“int lo”)
- High digital value (“int hi”)

2. If you press the Right Arrow key, the display goes from value to value in sequence. If you press the Left Arrow key, the display goes to the first value for the previous channel.
3. Use the HHP keypad to enter values. To enter a negative value, first enter the numbers, then press the +/- key.
4. Use the ENT key to save the selections on this screen and go to the next item.

Note

Range Selection is a setup parameter; it is not ordinarily changed while the module is operating.

5. From the last scaling screen, press the Right Arrow key to go to the original slot configuration screen.

Monitoring and Forcing I/O Data

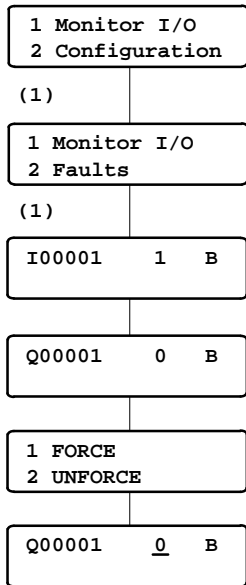

From the main menu, press the 1 key (Monitor I/O). This menu appears:

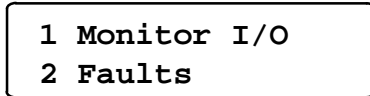

From this menu, you can:

- Press the 1 key to display and force I/O data.
- Press the 2 key to display fault information.

Looking at I/O Data

When you press 1 from the Monitor I/O menu, the HHP displays I/O data starting with the first configured discrete input (I) data. Press the Right Arrow key to display more data in this sequence:

- All discrete inputs (I)
- All discrete outputs (Q)
- All analog inputs (AI)
- All analog outputs (AQ)

The illustration below shows the format of the data display screens.

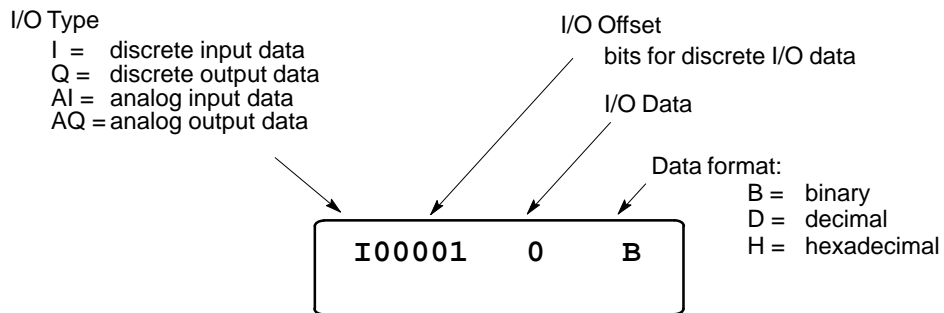

Changing the Data Display Format: Binary, Hex, Decimal

To change the data format, press the DEC/HEX key.

I00001	0	B	Binary format
I00001	007E	H	Hexadecimal format
I00001	+00216D		Decimal format

Forcing and Unforcing Data

To force data with the Hand-held Programmer:

1. Place the HHP in the correct display format:
 - A. Binary for discrete data.
 - B. Hex or decimal for analog data.
2. Select the data to be forced or unforced. For example:

```
I00001  0  B
```

3. Press the **ENT** key. The screen displays:

```
1 Force
2 Unforce
```

4. To force the point, press the **1** key. A cursor appears on the screen, indicating that the HHP is ready for you to enter the intended force value from the keypad.

```
I00001  0  B
```

Enter the force value and press the **ENT** key. An asterisk after the value indicates that it is forced.

```
I00001  *1  B
```

5. To remove the force, press the **ENT** key to display the Force menu. Press the **2** key.

Displaying and Clearing Faults with the HHP

The Bus Interface Unit reads faults from I/O modules. It can store up to 32 uncleared faults (both BIU and module faults) in its internal fault table. As faults occur, the first 16 are saved in the internal table. They stay there until the faults are cleared; none of these 16 faults is lost if the table overflows. However, for faults 17 through 32, the internal fault table operates as a First-In-First-Out stack. When fault 33 occurs, fault 17 is dropped from the table.

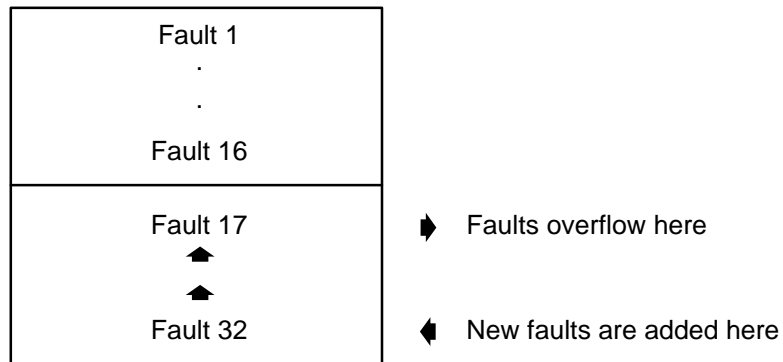

Faults are reported to the master automatically in the BIU's regular I/O data. The master can clear all faults in the BIU by setting a bit in the output data it sends to the BIU. See page 6-12 for information. In addition, the master can request specific diagnostic information from the BIU.

Faults can also be displayed and cleared with the Hand-held Programmer.

Displaying Faults

- From the main menu, press the **1** key (Monitor I/O). This menu appears:

```
1 Monitor I/O
2 Configuration
```

(1)

```
1 Monitor I/O
2 Faults
```

(2)

```
1 Monitor I/O
2 Faults
```

- From this menu, press the **2** key to display the Faults menu.

```
1 First 16 Flts
2 Last 16 Flts
```

```
1 First 16 Flts
2 Last 16 Flts
```

- Press the **1** key or the **2** key to display a set of 16 faults (one fault at a time). For example:

```
Slot 1 Fault#01
CONFIG MISMATCH
```

```
Slot 2 Fault#02
Loss I/O Module
```

```
1 Clear
2 Exit
```

```
Slot #1 Fault#01
CONFIG MISMATCH
```

Clearing Faults

To clear all faults, press the **ENT** key from the Fault display. The following menu appears:

```
1 Clear
2 Exit
```

Press the **1** key to clear all the faults that are presently in the BIU's internal fault tables. (Any faults that still exist are reported again).

Clearing faults from the Hand-held Programmer does not clear faults at the host PLC. To keep the entire system in step and up-to-date, fault clearing should be performed from the host PLC.

If you want to exit the menu without clearing faults, press the **2** key.

Chapter 5

Operation

This chapter is a general description of the operation of the Profibus BIU.

Overview

When the BIU is powered up, it performs a series of self-diagnostic tests including EPROM checksum verification, RAM testing, and communication testing.

Next, the Bus Interface Unit starts scanning the Field Control modules in the I/O Station to identify those present.

The Bus Interface Unit scans I/O modules in its station in the order of their physical location.

The Bus Interface Unit stores input data in its own I and AI memories. These memories always contain the most recent value for each input.

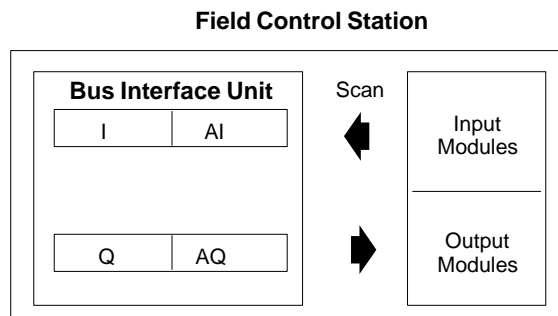

After the input scan, the Bus Interface Unit scans the output modules in order, sending them the most recent output data from its internal discrete output (Q) and analog output (AQ) memories.

Communications Startup

The BIU cannot communicate on the Profibus until the master provides it with appropriate communications parameters. See chapter 5 for details.

I/O Scanning Enabled or Disabled

Ordinarily, the I/O scanning of the BIU is enabled. However, it can be disabled if necessary (for example, during system setup and testing) with a Hand-held Programmer.

I/O Data

After communications have been successfully established, the BIU supplies input data to the master by responding to data exchange request messages.

The lengths of the input data and output data exchanged are established by the BIU's network I/O map configuration. Similar information must be supplied to the master separately. Before the exchange of I/O data begins, the master sends the BIU a message containing its configuration parameters. The BIU checks these parameters to be sure they match its own. If they do, the BIU starts sending data to the master upon request.

Input Data Sent by the Bus Interface Unit

The amount of input data sent to the master is equal to the total discrete input (I) and analog input (AI) lengths configured in the BIU's network I/O map. The BIU sends one input message to the master containing all input data from its configured I/O map addresses. The data is sent in the same sequence the modules occupy in the I/O Station—first input module's data, second input module's data, and so on. If one module provides both discrete and analog input data, its discrete data will be placed before its analog data.

The maximum overall length of input data is 128 bytes. An additional 2 bytes at the start of the message are used by the BIU for diagnostics messages to the master. So the actual maximum length of the input message from the BIU is 130 bytes.

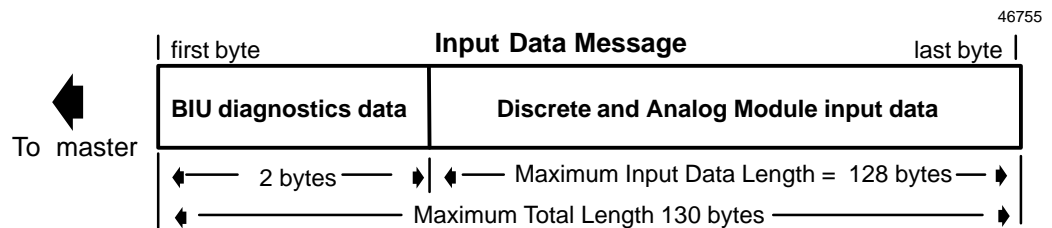

The diagram below shows an example input data message for an I/O Station that includes a discrete input module (IC670MDL640) in slot 2 and an analog input module (IC670ALG230) in slot 8. The total length of the example input data is 20 bytes.

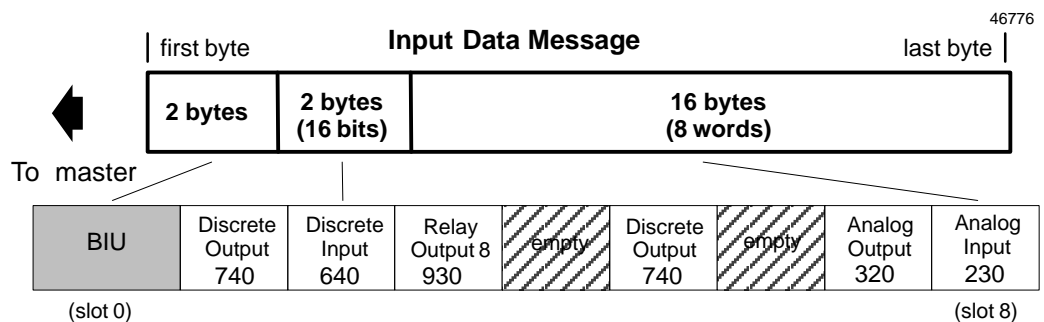

Input Defaults

When configuring input modules, either a default state (0) or hold last state can be selected (see chapter 3 for more information). If an input module is removed or fails to operate correctly, the chosen default state is substituted for actual input data. A diagnostic message is provided to indicate loss of module. Forced input data is not affected.

Outputs from the Master to the BIU

The amount of output data received from the master is equal to the total configured discrete output (Q) and analog output (AQ) lengths configured in the BIU's network I/O map. The BIU receives one output message from the master containing all the output data for its configured I/O map. The data is received in the same sequence the modules occupy in the I/O Station—first output module's data, second output module's data, and so on. If one module receives both discrete and analog output data, its discrete data will be located before its analog data.

The maximum overall length of this output data is 128 bytes. An additional 2 bytes at the start of the message are used by the master for fault clearing. So the actual maximum length of the output message from the master is 130 bytes.

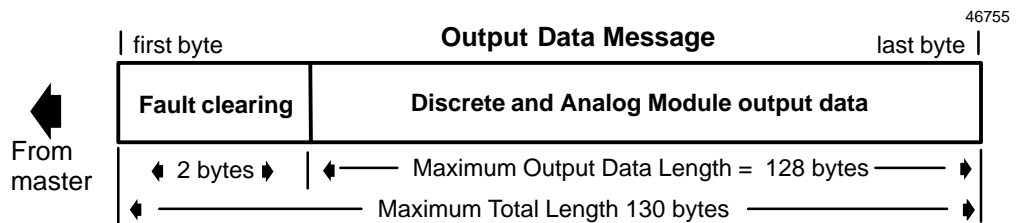

The diagram below shows an example output data message for an I/O Station that includes discrete output modules (IC670MDL740) in slots 1 and 5, a relay output module (IC670MDL930) in slot 3 and an analog output module (IC670ALG320) in slot 7. The total length of the example input data is 15 bytes.

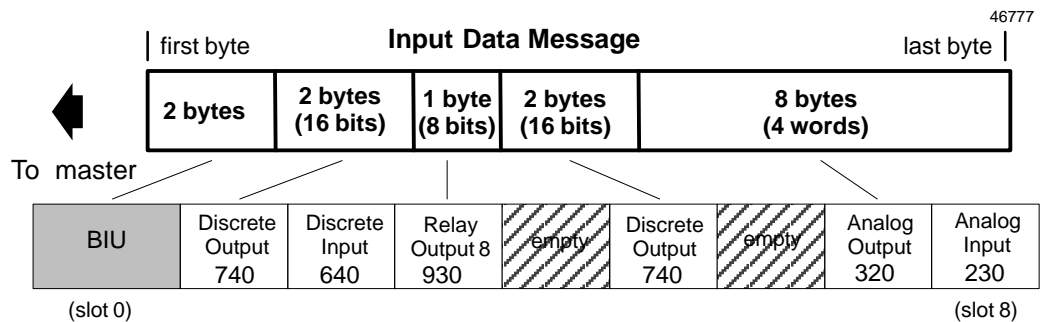

Output Defaults

On powerup, all outputs go to their configured default state, except outputs which had previously been forced—they go immediately to their forced state or value. Outputs remain at the Output Default State until the module receives output data from the master. Outputs do not “glitch on” during powerup.

Diagnostics

The Profibus BIU provides two separate ways to access and clear faults in the I/O station: through a Hand-held Programmer and from the master.

Both the Hand-held Programmer and master get data on module faults from the BIU's internal fault table. The master also has access to additional diagnostics information about the communications status of the BIU.

This section is a description of these diagnostics capabilities. It gives:

- the format of the BIU fault table.
- A list of the module and point diagnostics that are available to the master.
- A list of the communications diagnostics that are available to the master.

The instructions for displaying and clearing faults with a Hand-held Programmer are located in chapter 4.

The formats of diagnostic and fault clearing data exchanged between the BIU and the master are located in chapter 6.

The BIU Fault Table

The Bus Interface Unit maintains an internal fault table that can store up to 32 uncleared faults. As faults occur, the first 16 are saved in the table. They stay there until the faults are cleared; none of these 16 faults is lost if the table overflows. However, for faults 17 through 32, the internal fault table operates as a First-In-First-Out stack. When fault 33 occurs, fault 17 is dropped from the table.

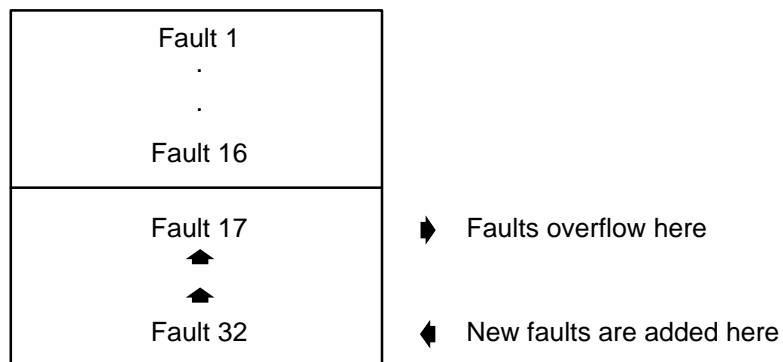

These faults can include both the standard diagnostics provided by the FieldControlI/O modules and the BIU's own diagnostics.

Faults are reported to the master automatically in the BIU's regular I/O data. The master can request individual faults from the BIU, and the master can clear all faults by setting a bit in the output data it sends to the BIU. See page 6-12 for information. This fault information can also be read from a class 2 master such as a programmer.

In addition, contents of the BIU fault table can be displayed and cleared using a Hand-held Programmer.

Module and Point Diagnostics Provided to the Master

The first two bytes of input data from the BIU to the master are reserved for diagnostics data. Each input data message can contain one fault from the BIU fault table. The message contains the point number and slot location where the fault occurred and a number that corresponds to one of the following types of faults:

- corrupted EEPROM
- unsupported feature
- calibration memory failure
- configuration mismatch
- fuse blown
- loss of module
- addition of module
- extra module
- loss of user power
- open wire
- high alarm
- low alarm
- overrange
- underrange
- short circuit
- unknown fault

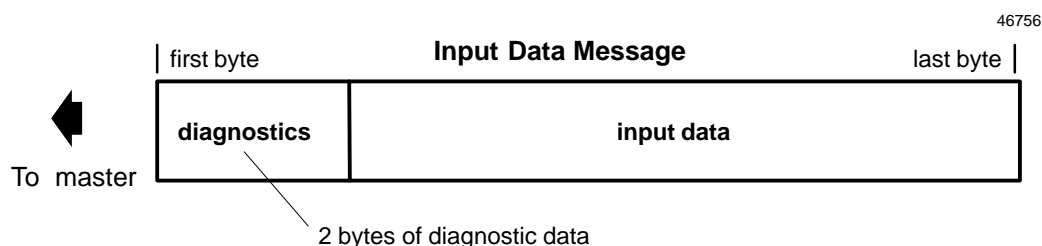

Details of this data message are located on page 6-11.

Communications Diagnostics

In addition to the diagnostics in the BIU’s own fault table, the Profibus system provides diagnostics related to communications.

- Station not present
- Station not ready
- Configuration mismatch fault
- Invalid response
- Parameter fault
- Master lock: the BIU was parameterized by another master.
- Parameters required by the BIU
- Static diagnostics: the BIU wants the master to request diagnostics
- Watchdog on
- Freeze mode is active
- Sync mode is active
- Deactivated BIU
- Diagnostic Overflow
- Master Address
- ID number

The master periodically requests this diagnostic information using a Get Diagnostics message. This message is described starting on page 6-5.

Synchronizing I/O Data

The master can synchronize the I/O data of multiple BIUs (and other slave devices) by assigning the devices to groups and using a multicast message to temporarily control their I/O data.

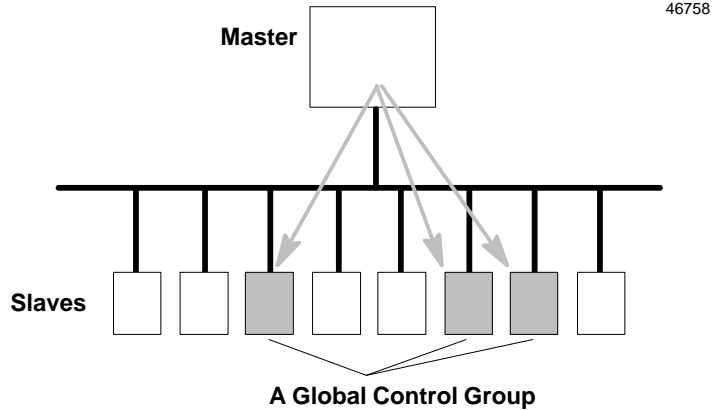

The master can command all of the devices in the group to:

- Clear the states of all their I/O data to 0.
- Freeze the content of their input data in BIU memory and ignore the actual input data being supplied by the I/O modules. Data remains frozen until commanded to unfreeze.
- Synchronize outputs across several devices by postponing the actual I/O state change until a Synch command is issued to the devices simultaneously.

Chapter 6

Communications

This chapter explains how Profibus master devices communicate with the Profibus Bus Interface Unit. The communications described in this chapter are controlled by the master through the application program. Specific Profibus system programming instructions are not included here.

Profibus Operation

The Profibus protocol utilizes both token-passing and master-slave communications for optimal efficiency.

- Token-passing is used to regulate which of several master devices (such as a PLC) is currently controlling the bus. When a master controls the bus it may communicate with other master devices or with slave devices such as a Field Control Profibus BIU. The token circulates from one master to another in the order of ascending addresses.
- Slave devices can never receive a token. Instead, their communications are completely controlled by a master that currently holds the token. The slave device in effect receives data or responds to a specific request for data from that master.

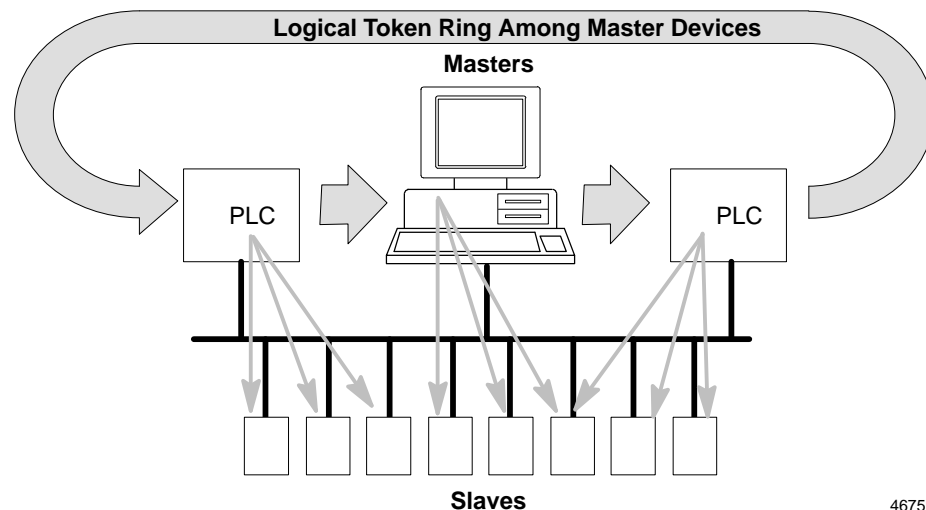

46759

For a certain time, after a master receives a token, it is allowed to exercise the master function on the bus. It can communicate with all slave stations in a master-slave relationship, and with all master stations in a master-master relationship.

The protocol recognizes the addition or removal of masters. It also detects transmission errors, addressing errors, and errors in token-passing.

Timing

Transmission time depends on the number of stations and the transmission speed. For example, the time to transmit 512 bit I/O data over 32 stations at 1.5 Mbits/sec is approximately 6 mS (see below). As the diagram illustrates, at 500 Kbits/sec (1/3 the transmission speed), the same amount of data would reach only 1/3 as many stations. Actual time should be calculated by the system administrator.

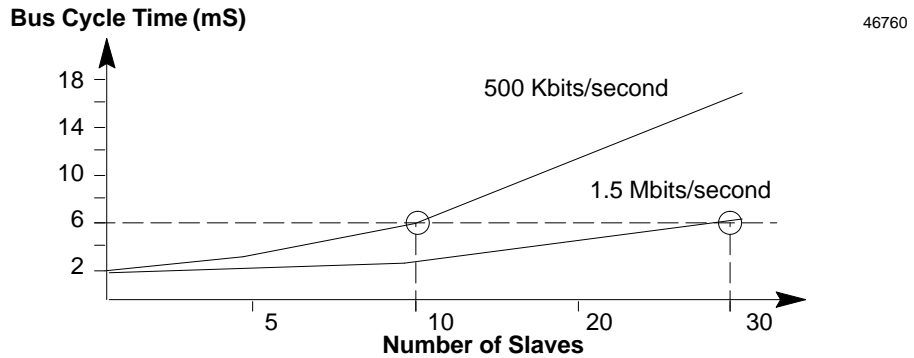

Communications between the Master and the BIU

The BIU operates as a slave device on the Profibus. All transmissions of I/O data and diagnostics must be initiated by a class 1 (controller) or class 2 (programmer) master. To communicate with a BIU (or other slave), a class 1 master must:

1. Set the parameters of the BIU using the DDLM_Set_Prm message.
2. Send the configuration to be checked by the BIU using the DDLM_Chk_Cfg message.
3. Transfer data using DDLM_Data_Exchange messages.

During operation, the class 1 master can also:

- Read diagnostics from the BIU using the DDLM_Slave_Diag message.
- Send data synchronization commands to groups of slaves using the DDLM_Global_Control function.

The formats of these messages and the message data structures are described on the following pages.

A class 2 master (programmer or monitoring device) can use the following commands to obtain information about the BIU:

- DDLM_RD_Inp and DDLM_RD_Outp messages provide information about the BIU's input and output data.
- DDLM_Get_Cfg can be used to read the BIU's configuration information.

Note that the DDLM_Set_Slave_Address function is not supported by this version of the Profibus BIU.

BIU Communications States

The BIU cannot communicate on the Profibus until the master provides it with appropriate communications parameters.

After successful powerup, the BIU waits for a DDLM_Set_Prm message from the master (see page 6-7). After receiving the parameter data, the BIU checks its validity and sends an acknowledgement to the master.

If the data was valid, the BIU next waits for a DDLM_Chk_Cfg message from the master (see page 6-9). When the BIU receives this message, it checks its own configuration to be sure it matches what is expected by the master. The BIU sends a positive or negative acknowledgement to the master, depending on the validity of the configuration message. If the configuration sent by the master does not match that of the BIU, the BIU goes back to the Wait_Param state.

If the BIU has accepted both the parameter setting and configuration check, it enters Data Exchange mode (see page 6-11). It can then accept outputs from the master and provide inputs from the input modules in the I/O Station.

In Data Exchange mode, the BIU can also:

- Provide diagnostics to the master (see page 6-12).
- Accept Clear All Faults commands from the master (see page 6-12).
- Handle all the data management functions associated with the Field Control modules in the I/O station.

If the Profibus watchdog time is disabled by the master, the BIU remains in Data Exchange mode even if the master stops sending I/O data. The BIU keeps scanning I/O modules. The BIU continues to refresh data in its input tables, although the data is not read by the master. Output modules continue to receive the data already in the BIU's output tables, causing them to hold their last states. The BIU does not default outputs in this situation.

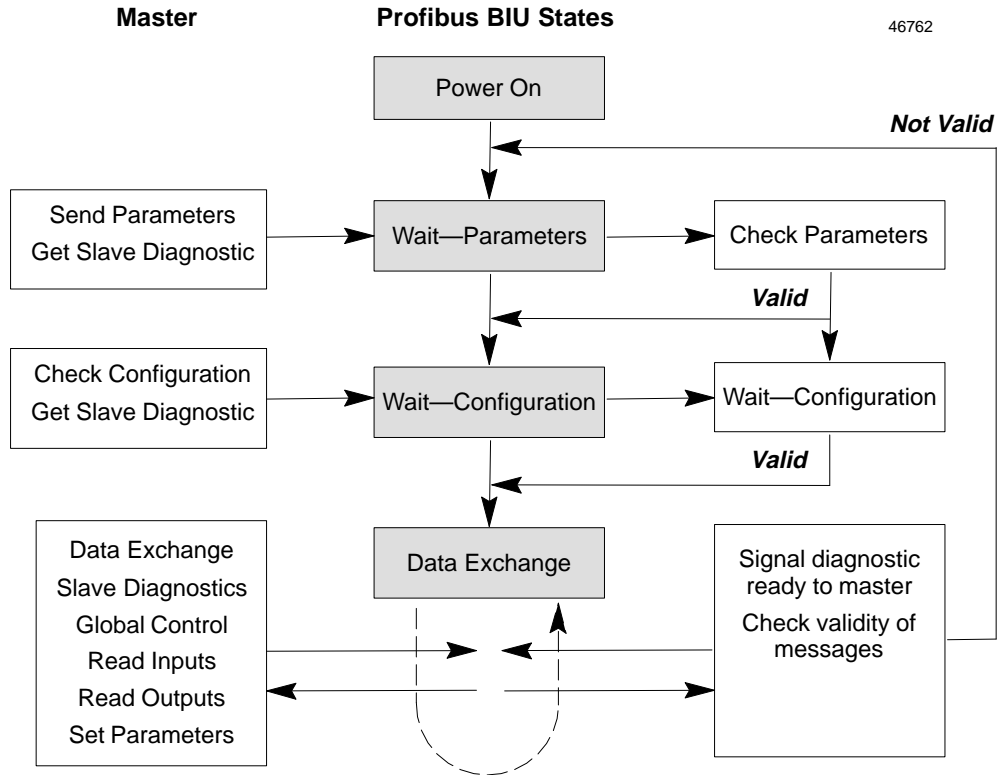

Reading BIU Diagnostics: DDLM_Slave_Diag

The master periodically sends the DDLM_Slave_Diag message to the BIU to request diagnostic information about the status of a Field Control I/O Station itself. The Profibus BIU uses only the first six bytes of this message.

At startup, the master uses this message to check the BIU status prior to sending the communications parameters or checking the BIU configuration.

If a class 2 master (such as a programmer) takes control of the BIU, the BIU temporarily stops exchanging data with its usual master (the master that supplied its communications parameters). By cyclically issuing a DDLM_Slave_Diag message to the BIU, that master can determine when the class 2 master has released its control. It can then resume normal I/O data transfer.

Message Contents: DDLM_Slave_Diag

Byte #	Description		
0	Bit	Station Status Byte #1	
	0	Station not present	Master cannot reach the BIU. If this bit is set to 1, the diagnostic bits contain the state of the previous diagnostic message. The BIU sets this bit to 0.
	1	Station not ready	The BIU sets this bit to 1 if it is not ready for data transfer.
	2	Configuration fault	The BIU sets this bit to 1 if the configuration sent by the master does not match its own.
	3	Extendeddiagnostic	The BIU sets this bit to 1 if the diagnostic length is more than 6 bytes. During the Wait_Param and Wait_Cfg phase, the BIU uses only the first 6 bytes of this message, so this bit should be 0.
	4	(Function) not supported	The BIU sets this bit to 1 if it receives a request for a function that it does not support.
	5	Invalidresponse	The master sets this bit to 1 if it receives an inconsistent response from the BIU. The BIU sets this bit to 0.
	6	Parameterfault	The BIU sets this bit to 1 if the last parameter frame was faulty (wrong length, ID, or parameters).
	7	Masterlock	The master sets this bit to 1 if the address in byte 4 is not its own address, indicating the BIU has been parameterized by another master. The BIU sets this bit to 0.
1	Bit	Station Status Byte #2	
	0	Parametersrequired	The BIU sets this bit to 1 if it needs to be reparameterized and reconfigured. The bit stays set until parameterization is finished.
	1	Staticdiagnostics	The BIU sets this bit to 1 if it wants the master to request diagnostics. For example, the BIU would set this bit if it is not able to provide valid user data. The master should continue to request diagnostic data until the BIU resets this bit to 0.
	2	(Set to 1 by the BIU)	
	3	Watchdog on	If the BIU sets this bit to 1, it indicates that the Watchdog Control in the BIU has been activated.
	4	Freeze mode	The BIU sets this bit to 1 when it receives the Freeze command.
	5	Sync mode	The BIU sets this bit to 1 when it receives a Sync command.
	6	reserved	
	7	Deactivated	The BIU sets this bit to 1 there is more channel diagnostic data than the BIU diagnostic buffer can contain or the master sets this bit if the BIU sends more diagnostic data than the master diagnostic buffer can contain.
2	Bit	Station Status Byte #3	
	0-6	Reserved	
	7	Diagnostic Overflow	The BIU sets this bit if it receives more module diagnostics data than it can accommodate. The master sets this bit if it receives more BIU diagnostics than it can accommodate.
3	Master Address		The address of the master that parameterized the BIU. If no master has parameterized the BIU, the BIU sets this byte to FF hex.
4-5	ID number.		For the GE Fanuc Profibus BIU, this is 0534 hex.
6 - 31	reserved data area		

Setting the BIU Communications Parameters: DDLM_Set_Prm

After successfully checking the diagnostics status of the BIU, the master begins communications with the BIU. It first uses a DDLM_Set_Prm message to send communications parameters.

These parameters establish:

- The ID number of the BIU (0534h).
- The watchdog time used by the BIU.
- The minimum time that can elapse between frames.
- A Group Identifier, if the BIU will be part of a group controlled using the DDLM_Global_Control message. See page 6-13 for more information.
- Whether Freeze mode is enabled or disabled.
- Whether Synchronization mode is enabled or disabled.
- Whether access by other masters is unlocked or locked. Access must be unlocked for a BIU that is also part of a global control group. See the next page.

The DDLM_Set_Prm message has 32 bytes; however, the Profibus BIU does not use any user-related parameters and the message should only contain the 7 first bytes specified in the standard.

After receiving the DDLM_Set_Prm message, the BIU sends back a positive acknowledgment if parameters are valid or a negative acknowledgment if they are not.

Message Contents: DDLM_Set_Prm

Byte #	Description																	
0	Station Status (see below)																	
1	Watchdog Factor 1. Range = 1 to 255. The time can be between 10mS and 650 seconds $T_{WD}[\text{seconds}] = 10\text{ms} \times (\text{Factor 1}) \times (\text{Factor 2})$																	
2	Watchdog Factor 2. Range = 1 to 255.																	
3	Minimum Station Delay Responder. This is the minimum time that can elapse between receiving the last bit in a frame and the first bit of the next frame. Note that the Minimum Station Delay Responder Time (Byte 3) can be set if both bits 6 and 7 of Byte 0 (see below) are set to 0, and the ID number is identical.																	
4, 5	ID Number. This number must match the BIU's own ID number, or it will not accept the Set_Prm message.																	
6	Group Identifier. This byte can be used to build groups for the function DDLM_Global_Control. Each bit represents a group. If a bit in this byte is set to 1 it indicates the control group (1–8) to which the BIU belongs). <div style="text-align: center; margin: 10px 0;"> <table style="border-collapse: collapse; margin: 0 auto;"> <tr> <td style="padding-right: 5px;">bits</td> <td style="border: 1px solid black; padding: 2px 5px;">7</td> <td style="border: 1px solid black; padding: 2px 5px;">6</td> <td style="border: 1px solid black; padding: 2px 5px;">5</td> <td style="border: 1px solid black; padding: 2px 5px;">4</td> <td style="border: 1px solid black; padding: 2px 5px;">3</td> <td style="border: 1px solid black; padding: 2px 5px;">2</td> <td style="border: 1px solid black; padding: 2px 5px;">1</td> <td style="border: 1px solid black; padding: 2px 5px;">0</td> </tr> <tr> <td style="padding-right: 20px;">Group 8</td> <td colspan="6" style="border: none; text-align: center;">_____</td> <td style="padding-left: 20px;">Group 1</td> </tr> </table> </div> The Group Identifier is accepted only if the Lock Access Bit (bit 7 of byte 0) is set to 1.	bits	7	6	5	4	3	2	1	0	Group 8	_____						Group 1
bits	7	6	5	4	3	2	1	0										
Group 8	_____						Group 1											
7 – 31	Not used by this version of the Profibus Bus Interface Unit.																	

Station Status Bits in Byte 0

The bits in byte 0 of the DDLM_Set_Prm message indicate the status of watchdog control, freeze mode, synchronization mode, and access by other masters.

If the BIU is included in a global control group (as indicated in byte 6) the Lock Access bit (bit 7) of this byte must be set to 1.

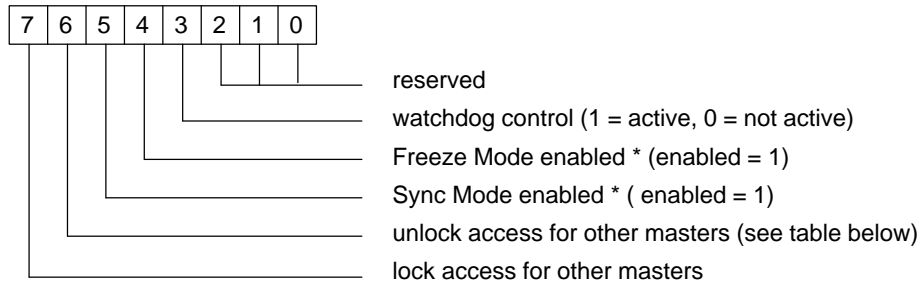

Bit 7	Bit 6	Meaning
0	0	Overwriting minimum Station Delay Time Responder and BIU-specific parameters is permitted. All other parameters are unchanged.
0	1	The BIU will be unlocked for other masters.
1	0	The BIU is locked for other masters. All parameters are accepted, except a minimum Station Delay Time Responder of 0.
1	1	The BIU is unlocked for other masters.

Example Configuration

The DDLM_Chk_Cfg message is not affected by empty slots in the I/O Station. So for the example I/O Station represented below, the master would send the following data in the DDLM_Chk_Cfg message:

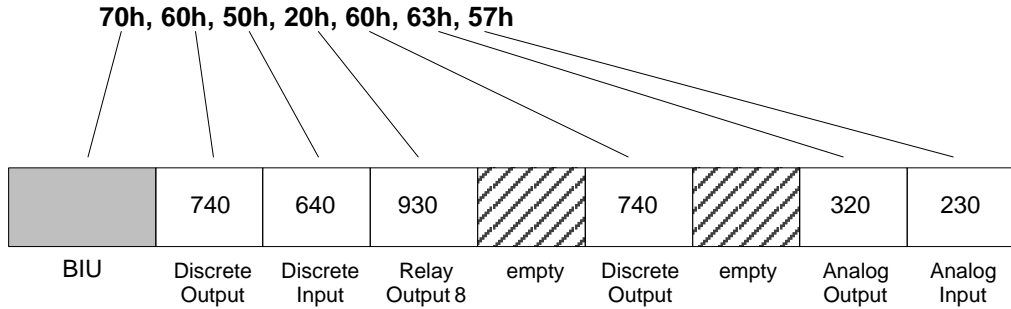

Ordinarily, there would not be empty slots between modules in an I/O Station. Autoconfiguration of the I/O Station does not skip empty slots, so the example I/O Station would require manual configuration of the modules to the right of the first empty slot even if the rest were automatically configured.

Exchanging I/O Data, Diagnostics, and Fault Clearing: DDL_M_Data_Exchange

The master uses the DDL_M_Data_Exchange message to exchange I/O, diagnostics, and command data with the Profibus BIU. Before accepting this message, the BIU must first have successfully accepted the Set_Prm and Chk_Cfg messages, as described on the previous pages.

The Data_Exchange message begins with two bytes of diagnostic data followed by inputs from the BIU, or two bytes of fault-clearing command data followed by outputs from the master.

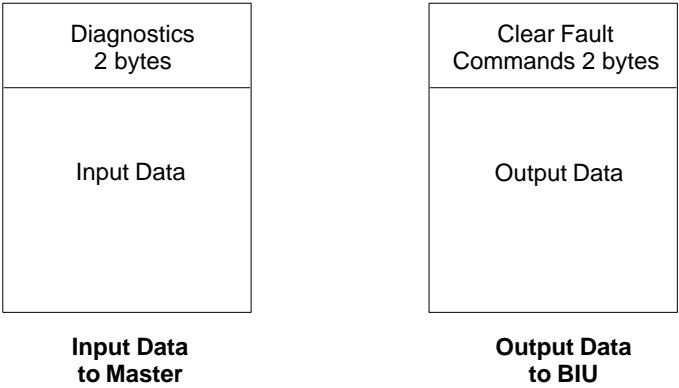

The Diagnostics word and Clear Fault Command word are always sent regardless of the BIU's configuration.

Configuration Required for Diagnostics/Fault Clearing

To exchange the two bytes of diagnostics and fault clearing data, the DDL_M_Set_Prm message sent by the master must include the BIU in slot 0 and reserve a length of 2 bytes for it. See the previous description of DDL_M_Chk_Cfg.

This diagnostics data is included in the total length of data that may be exchanged on the Profibus.

Format of the Diagnostics Data Word

As mentioned, the first two bytes of each Data_Exchange message are used for diagnostics and fault clearing.

Each Data_Exchange message sent by the BIU can contain one fault report. This Diagnostic Data word contains the slot and point number of the fault's location and a numerical value identifying the type of fault that has occurred.

The Diagnostics Data word has the following format:

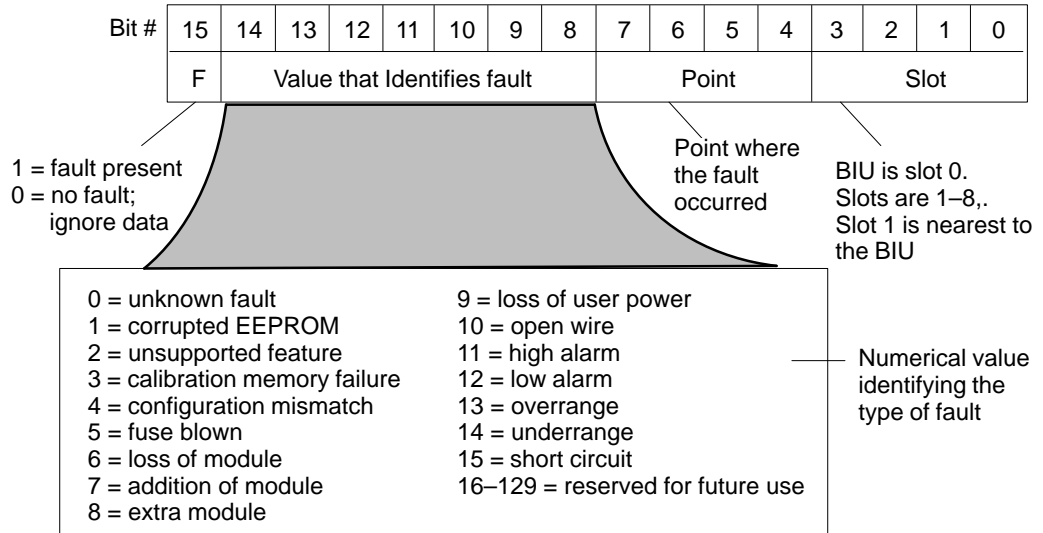

Clearing All Faults

Similarly, the first two bytes of each Data_Exchange message sent by the master can be used to request the next fault report from the BIU or to clear all faults in the BIU's internal fault table.

To request a fault report, the master should set the least significant bit of the least significant byte from 0 to 1. Upon noting the transition of this bit, the BIU will update its next Data_Exchange message with the next fault in its internal fault table. This does not remove the fault from the fault table or clear the fault.

If the master wants to clear all faults, it should set bit 7 (the MSB of the first byte) to 1. The Clear command is also transition-sensitive (from 0 to 1).

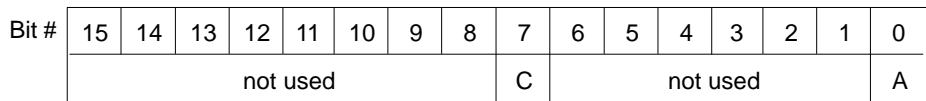

Clear All Faults:

If the master sets this bit to 1, the BIU clears ALL faults. This is equivalent to clearing all faults with a Hand-held Programmer. It is normally done when the BIU indicates that no more faults are present, to stop the flashing of the OK LED.

Fault Acknowledge:

When this bit transitions from 0 to 1, the BIU sends the next fault in the fault table.

Note that if all faults are cleared and fault conditions are still present, the BIU generates a new diagnostics message.

Synchronizing I/O Data: DDLM_Global Control

The master can synchronize the I/O data of multiple BIUs (and other slave devices) using the DDLM_Global_Control message. Each BIU can be included in a Global Control group with the other devices with which it will be synchronized.

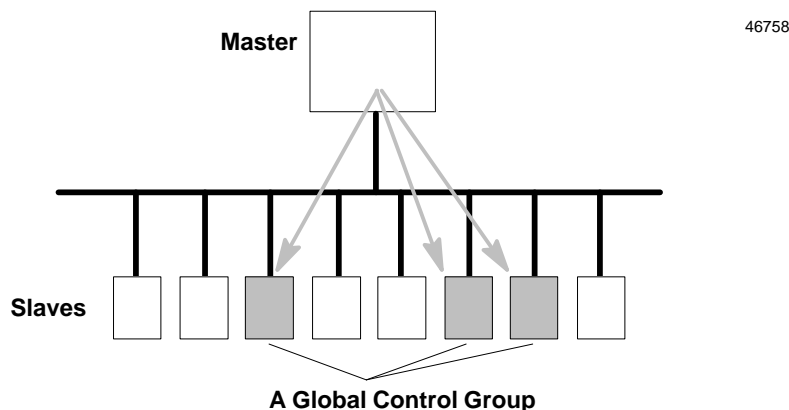

The DDLM_Global_Control message controls only the synchronization. Inputs from the modules or outputs from the master can be frozen by the BIU, data which has been frozen can be unfrozen, or all outputs at the BIU can be set to zero.

The actual transfer of I/O data is handled in the usual way with the DDLM_Data Exchange message.

The DDLM_Global_Control message sent by the master includes the control command (shown below). It must also specify for which global control group the message is intended.

Parameter Contents: Control_Command

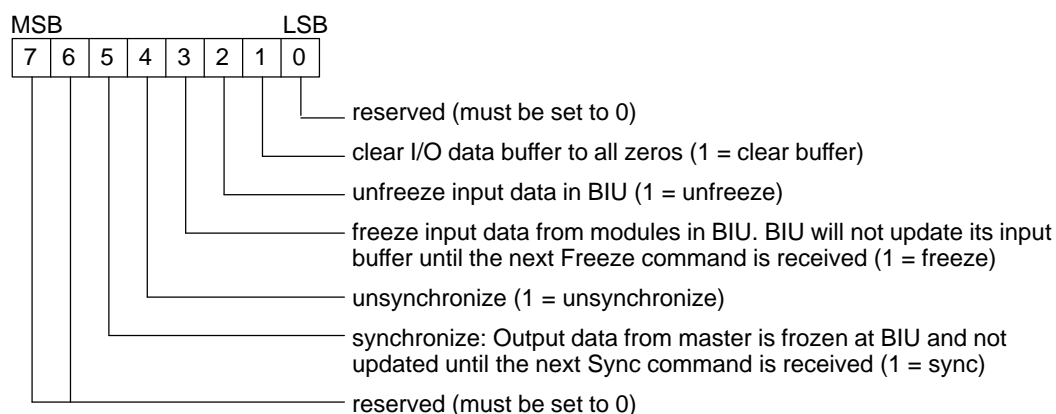

The assignment of the BIU to a specific global control group is made by setting a bit in the DDLM_Set_Prm message, as shown on page 6-7.

Note that failing to set the reserved bits to 0 or setting conflicting bits to 1 in this message will cause the BIU to return to Wait_Param mode and to send a "Not Supported" error message to the master.

Additional Messages for Programming Devices (Class 2 Masters)

The messages described on the previous pages are exchanged between the BIU and a Class 1 master such as a PLC or other type of system controller.

Class 2 masters, such as programming devices, can additionally use the following two messages to read information from the BIU:

- DDLM_Get_Cfg can be used to read the BIU configuration.
- DDLM_RD_Inp and DDLM_RD_Outp can be used to read the BIU IO buffers.

DDLM_Get_Cfg

A class 2 master reads the configuration of the Profibus BIU by sending the BIU a DDLM_Get_Cfg message.

The message contents is the same as for DDLM_Chk_Cfg. There is 1 byte of data for each I/O module and the BIU.

Data Format for Each Module

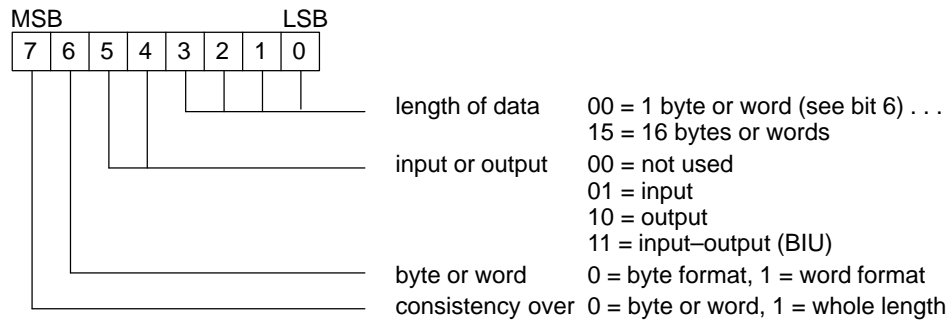

For examples, see DDLM_Chk_Cfg on page 6-9.

DDL_M_RD_Inp and DDL_M_RD_Outp

A class 2 master read the I/O buffers of the Profibus BIU using the DDL_M_RD_Inp and DDL_M_RD_Outp messages.

The message contents are the same as for DDL_M_Data_Exchange.

The DDL_M_RD_Inp message begins with two bytes of diagnostic data (see below) followed by inputs from the BIU.

The DDL_M_RD_Outp message begins with two bytes of fault-clearing command data followed by outputs from the master.

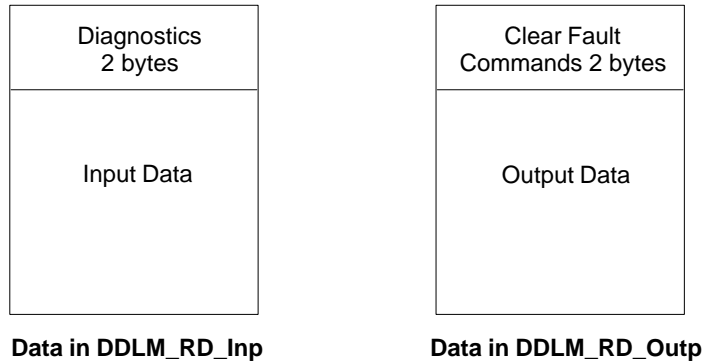

The Diagnostics Data word in the DDL_M_RD_Inp message has the same format as DDL_M_Data_Exchange (see page 6-11).

A

- Addition of Module message, 3-6
- Address selection, DIP switches, 2-6
- Alarm thresholds, configuring for analog input module, 4-18
- Analog input module, configuration instructions, 4-16
- Analog inputs, 5-2
- Analog Output Module, configuration instructions, 4-20
- Analog outputs, 5-3
- Autoconfiguration
 - adding and deleting modules, 3-6
 - configuration protection, 4-6
 - disable, 3-5, 4-6
 - I/O references assigned, 3-3
 - overview of, 3-2
 - with a Hand-held Programmer, 3-5, 4-6
 - with empty slot, 3-3
- Auxiliary I/O Terminal Block, 1-3

B

- Binary data, 4-24
- BIU communication states, 6-3
- BIU diagnostics, 5-5
- BIU fault table, 5-4
- Boot loader, 2-19
- Bus
 - cable specifications, 2-14
 - cable types, 2-14
 - connecting to Bus Interface Unit, 2-13
 - length, 2-14
 - termination, 2-15
- Bus ID, configuration with HHP, 4-5
- Bus Interface Unit
 - description, 1-6
 - dimensions, 1-6
 - functional specifications, 1-11
 - fuse, 1-6
 - installing on terminal block, 2-9
 - introduction, 1-3
 - power supply, 1-7
 - removing from terminal block, 2-3, 2-9
 - terminal block, 1-3, 1-10

C

- Cables, between terminal blocks, 1-10
 - installing, 2-8
- Channel active, configuring for analog input module, 4-17, 4-22
- Clearances required, 2-4
- Communications
 - diagnostics, 5-5
 - loss of, 5-3
 - overview, 6-2
 - parameters, 6-7
 - startup, 5-1
- Configuration
 - HHP menus, 4-4
 - instructions for using HHP, 4-8
 - reading from programmer, 6-14
 - selectable features, 1-12
- Configuration instructions
 - analog input module, 4-16
 - analog output module, 4-20
 - discrete input module, 4-12
 - discrete output module, 4-14
- Configuration Mismatch message, 3-6
- Configuration protection, enable or disable, 4-4
- Control wiring, 2-10
- Current/voltage range
 - configuring for analog input module, 4-17
 - configuring for analog output module, 4-22

D

- Data Exchange mode, 6-3, 6-11
- DDL_M_Chk_Cfg, 6-9
- DDL_M_Data_Exchange message, 6-11
- DDL_M_Global_Control message, 6-13
- DDL_M_Set_Prm, 6-7
- DDL_M_Slave_Diag, 6-5, 6-6
- Decimal data, 4-24
- Default or hold last state
 - configuring for analog input module, 4-19
 - configuring for analog output module, 4-20

- configuring for discrete input module, 4-13
- configuring for discrete output module, 4-14
- Defaults, for configurable module features, 3-2
- Delay between messages, 6-7
- Diagnostics, 6-5
 - BIU, 5-5
 - communications, 5-5
 - data format to master, 6-12
 - module, 5-5
- DIN rail
 - installing Terminal Block, 2-5
 - mounting, 2-4
 - removing Terminal Block, 2-18
- DIP switches
 - board address selection, 2-6
 - Profibus protocol selection, 2-6
- Discrete input module, configuring, 4-12
- Discrete inputs, 5-2
- Discrete output module, configuring, 4-14
- Discrete outputs, 5-3

E

- Empty slots in I/O Station, 6-10
- Enclosures, 1-4
- ESD protection, 2-2
- Extra Module message, 3-6

F

- Fault reporting
 - configuring for analog input module, 4-16
 - configuring for analog output module, 4-20
 - configuring for discrete input module, 4-12
 - configuring for discrete output module, 4-15
- Fault reports, enable or disable, 4-4
- Fault table, 5-4
- Faults
 - clearing from master, 6-12

- displaying and clearing, 4-26
- reading from master, 6-12
- Features, 1-1
- Firmware upgrade, 2-19
- Forcing data, 4-25
- Freeze mode enabled bit, 6-8
- Freezing input data, 6-13
- Fuse, Bus Interface Unit, 1-6, 2-17

G

- Grounding, system, 2-11
- Group Identifier, 6-7

H

- Hand-held Programmer
 - change data format, binary, hex, decimal, 4-24
 - connection to Bus Interface Unit, 4-2
 - connector on Bus Interface Unit, 1-6
 - Menus, 4-3
 - screen format for displaying/forcing data, 4-24
 - using with Profibus BIU, 1-12
- Hex data, 4-24
- HHP module configuration instructions, 4-10
- Humidity specification, 1-5

I

- I/O data
 - examples, 3-3
 - length, 5-2
 - reading from programmer, 6-15
- I/O map, data lengths and types, 4-8
- I/O modules
 - configure type, 4-11
 - introduction, 1-3
 - locations for, 1-4
- I/O Scanning, instructions to enable or disable, 4-7
- I/O Scanning enabled or disabled, 5-1
- I/O tables, setting all data to zeros, 6-13
- I/O Terminal Blocks, introduction, 1-3

ID number, 6-7
Input module, analog, configuration instructions, 4-20
Input power requirements, 1-8
Inputs, 5-2
 length and references in BIU, 4-8

L

LEDs, 2-16
Load requirements for hardware components, 1-9
Locations for I/O modules, 1-4
Logic power, 1-7
Loss of Module message, 3-6

M

Master access locked bit, 6-8
Messages
 DDL_M_Chk_Cfg, 6-9
 DDL_M_Data_Exchange, 6-11
 DDL_M_Global_Control, 6-13
 DDL_M_Set_Prm, 6-7
 DDL_M_Slave_Diag, 6-5, 6-6
Module configuration formats sent to master, 6-9
Module current requirements, 1-9
Module defaults, 3-2
Module diagnostics, 5-5
Modules
 I/O modules, 1-3
 I/O Terminal Blocks, 1-3
 types of, 1-2
Mounting clearances, 2-4
Mounting positions, 1-4
Mounting screws, 2-4

N

Noise
 preventing, 2-10
 specifications, 1-5

O

Operation overview, 5-1
Output defaults, 5-3
Outputs
 length and references in BIU, 4-8
 sent by master, 5-3

P

Panel mounting, 2-4
Parameters at startup, 6-3
Pin assignments for the bus connectors, 2-13
Power
 specifications, 1-11
 to Bus Interface Unit, 2-12
 wiring, general information, 2-10
Power dissipation, 1-9
Power Supply
 input power requirements, 1-8
 specifications, 1-11
 timing, 1-7
Preinstallation check, 2-2
Profibus, bus specifications, 1-13
Profibus operation, 6-1
Profibus protocol, selecting type with DIP switches, 2-6

R

Reading module configuration with HHP, 4-11

S

Scaling values
 configuring for analog input module, 4-18
 configuring for analog output module, 4-23
Signal wiring, 2-10
Slave devices, 6-1
Slots, empty, 6-10
Software version
 BIU communication software, 4-5

BIU core software, 4-4
Specifications, 1-11
 See also individual I/O module data-sheets
 electrical, 1-11
 environmental, 1-5
 noise, 1-5
 temperature, 1-5
 vibration, 1-5
Standards, 1-5
Startup, communications, 5-1
Sync mode enabled bit, 6-8
Synchronizing output data, 6-13

T

Temperature specifications, 1-5
Terminal Block
 installing on DIN rail, 2-5

 removing from DIN rail, 2-18
Termination, 2-15
 12 Mbit busses, 2-15
Timing, 6-2
Token passing, 6-1
Transmission rate, 2-14
Transmission time, 6-2

V

Vibration specification, 1-5

W

Watchdog, 6-7
Watchdog enabled bit, 6-8
Wiring guidelines, 2-10